



REFRIGERATION PRESSURE VESSELS





Custom Designed & Manufactured • Superior Quality



RVS Manufacturing Facility, Bryan, TX.

RVS Corporation was founded in 1983 and manufactures quality ASME pressure vessels, vessel packages and controls for the Industrial Refrigeration Food and Beverage Industry, Oil and Gas Industries, and the Petrochemical Industry. RVS was acquired by EVAPCO, Inc. in 1994 with EVAPCO being recognized as the leading supplier of quality heat transfer equipment to the Industrial Refrigeration, HVAC, Process Cooling and Power Industries. The success of RVS/EVAPCO has been the result of a continual commitment to product improvement, quality workmanship, and a dedication to providing unparalleled customer service and satisfaction.

All pressure vessels and packages are manufactured to ASME Boiler and Pressure Vessel Code, Section VIII, Division 1, latest revision and in accordance with ASME B31.5. RVS has a newly renovated and expanded facility in Bryan, Texas with approx. 100,000 square feet of manufacturing area and office complex. Processes include plasma cutting, plate rolling, shot and sand blasting, multiple welding processes, testing, and a state-of-the-art paint booth.

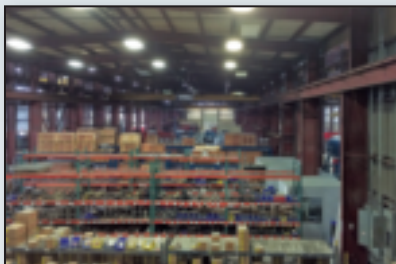

RVS is committed to providing superior technical support and the highest quality products with on-time shipments to meet your construction schedule!



Pressure Vessel Fabrication Capabilities



60" Dia. x 60' 0" Vertical Still Vessel



48" Dia. x 8' 0" Vertical Reflux Accumulator



36" Dia. x 52' 0" Vertical Amine Contactor



72" Dia. x 24' 0" Horizontal Flash Receiver



108" Dia. x 45' 0" Horizontal R-134A Receiver



30" Dia. 8' 0" Horizontal Surge Drums with Level Columns Mounted

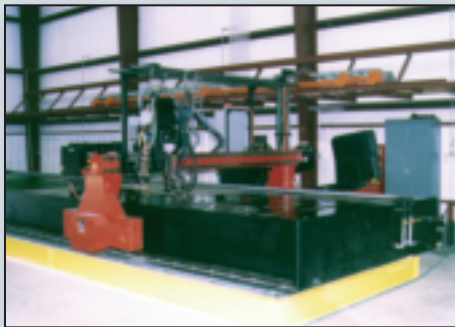

CNC Plasma Cutting Table



Submerged Arc Welder



Plate Bending Rolls



Low temperature refrigeration skid package

In-house capabilities including shot blasting, painting, piping and complete electrical wiring allow us to provide customers with a finished product ready for installation at the jobsite without the additional time and expense of shipping it to a subcontractor. All piping systems are designed and fabricated to the requirements of ASME Standard B31.3 for Process Piping and B31.5 for Refrigeration Piping.



Liquid recirculator package with pumps and controls



Horizontal High Pressure Receivers 250# DWP

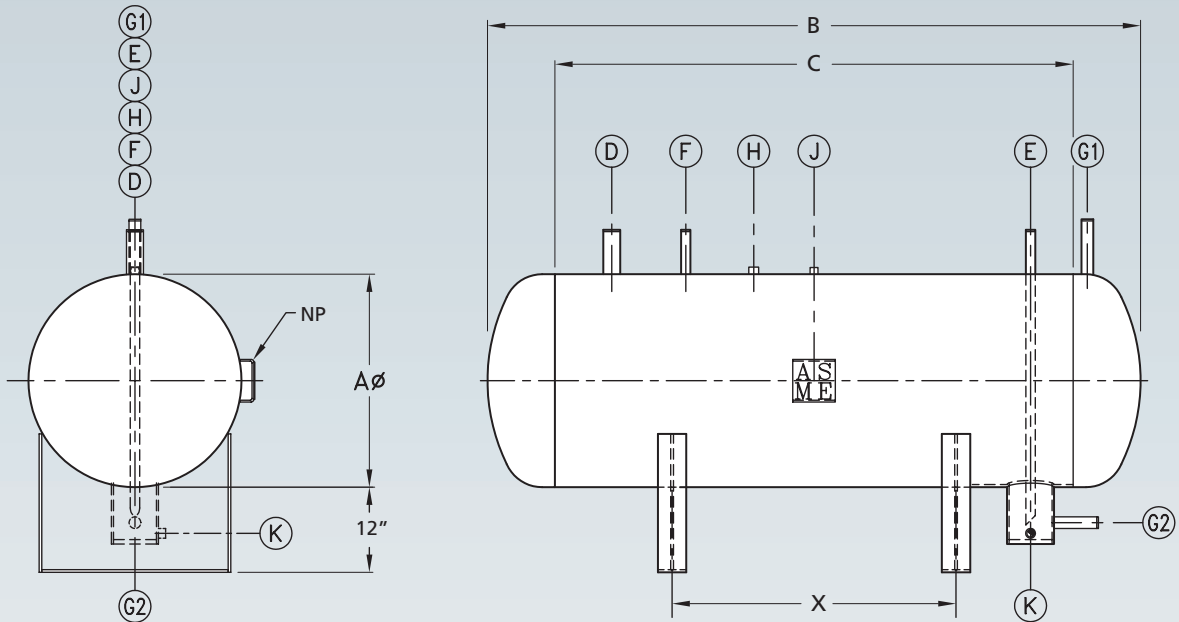

Model No.	A Diameter	B Overall Length	C Shell Length	D Liquid Inlet	E Liquid Outlet	F Equalizer	G Level Column	H Purge	J Relief	K Drain	X Saddles	(lbs.) Vessel Weight	(Ft ³) Internal Volume	(lbs. @ 80%) Pumpdown Capacity
HHPR20-96	20	96	81	1-1/4	1	3/4	1-1/4	3/4	1/2	3/4	48	870	16.1	472
HHPR20-144	20	144	129	1-1/2	1	1	1-1/4	3/4	1/2	3/4	86	1,200	23.7	695
HHPR24-144	24	144	127-1/2	2	1-1/4	1	1-1/4	3/4	1/2	3/4	86	1,480	34.9	1,024
HHPR24-192	24	192	175-1/2	2	1-1/4	1-1/4	1-1/4	3/4	1/2	3/4	116	1,850	47.3	1,388
HHPR30-138	30	138	119	2	1-1/4	1-1/4	1-1/4	3/4	1/2	3/4	80	1,770	51.0	1,497
HHPR36-141	36	141	119	2-1/2	1-1/2	1-1/2	1-1/4	3/4	1/2	3/4	83	2,200	75.7	2,221
HHPR42-144	42	144	119	3	2	2	1-1/4	3/4	3/4	3/4	72	2,630	105	3,081
HHPR48-147	48	147	119	3	2	2	1-1/4	3/4	3/4	3/4	74	3,070	139	4,079
HHPR48-266	48	266	238	4	2-1/2	2-1/2	1-1/4	3/4	3/4	3/4	158	5,090	266	7,806
HHPR54-150	54	150	119	4	2-1/2	2-1/2	1-1/4	3/4	3/4	3/4	75	5,880	185	5,429
HHPR54-269	54	269	238	5	3	3	1-1/4	3/4	1	3/4	161	7,700	339	9,948
HHPR60-153	60	153	119	4	2-1/2	2-1/2	1-1/4	3/4	1	3/4	77	5,480	231	6,778
HHPR60-272	60	272	238	5	3	3	1-1/4	3/4	1	3/4	162	8,830	421	12,354
HHPR72-159	72	159	119	5	3	3	1-1/4	3/4	1	3/4	80	8,500	343	10,065
HHPR72-276	72	276	236	6	4	4	1-1/4	3/4	1	3/4	166	13,600	617	18,105
HHPR84-165	84	165	119	5	4	4	1-1/4	3/4	1	3/4	74	10,510	478	14,026
HHPR84-282	84	282	236	6	5	5	1-1/4	3/4	1	3/4	168	16,415	856	25,118
HHPR96-171	96	171	119	6	4	4	1-1/4	3/4	1	3/4	73	13,450	646	18,956
HHPR96-288	96	288	236	8	5	5	1-1/4	3/4	1-1/4	3/4	176	20,210	1,131	33,188
HHPR108-177	108	177	119	6	5	5	1-1/4	3/4	1	3/4	65	17,280	826	24,238
HHPR108-296	108	296	238	8	6	6	1-1/4	3/4	1-1/4	3/4	170	26,535	1,462	42,901
HHPR120-183	120	183	119	8	5	5	1-1/4	3/4	1-1/4	3/4	65	26,100	1,046	30,694
HHPR120-302	120	302	238	10	6	6	1-1/4	3/4	2	3/4	170	39,700	1,831	53,729
HHPR144-195	144	195	119	10	6	6	1-1/4	3/4	2	3/4	60	36,140	1,583	46,452
HHPR144-314	144	314	238	12	6	6	1-1/4	3/4	(2) 1-1/4	3/4	166	52,140	2,714	79,640

Notes: All dimensions are given in inches.
Pumpdown capacity is given in lbs of R-717 at 80% full and +95°F
Consult factory for certified drawings.

Vertical High Pressure Receivers 250# DWP

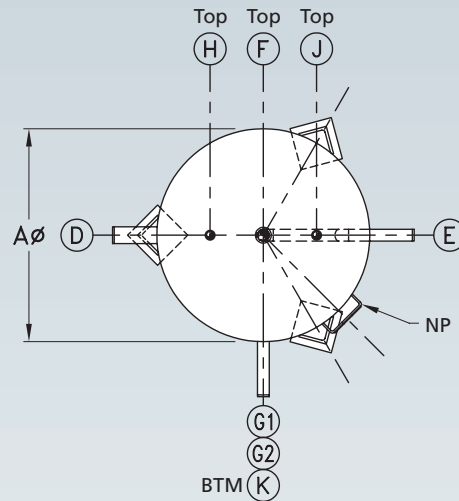
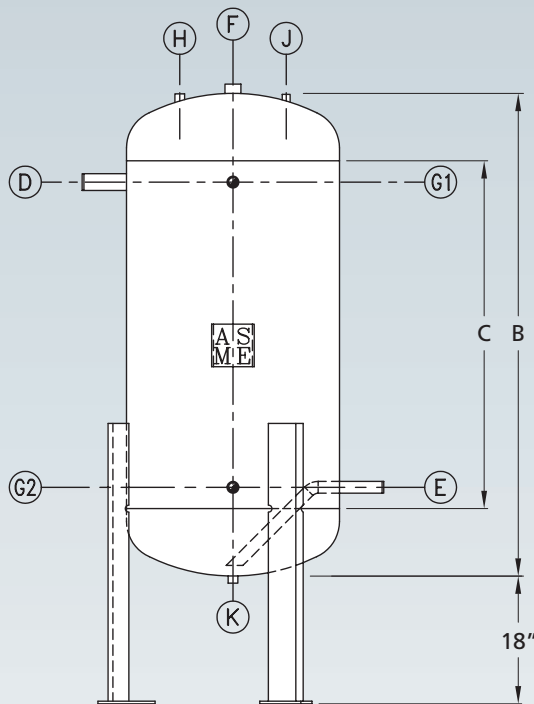

4 Legs required on vessels 84" O.D. and above.

Model No.	A Diameter	B Overall Length	C Shell Length	D Liquid Inlet	E Liquid Outlet	F Equalizer	G Level Column	H Purge	J Relief	K Drain	(lbs.) Vessel Weight	(F ³) Internal Volume	(lbs. @ 80%) Pumpdown Capacity
VHPR20-144	20	144	129	1-1/2	1	1	1-1/4	3/4	1/2	3/4	1,200	23.7	695
VHPR24-144	24	144	127-1/2	2	1-1/4	1	1-1/4	3/4	1/2	3/4	1,330	34.9	1,024
VHPR30-138	30	138	119	2	1-1/4	1-1/4	1-1/4	3/4	1/2	3/4	1,695	51.0	1,497
VHPR36-141	36	141	119	2-1/2	1-1/2	1-1/4	1-1/4	3/4	1/2	3/4	2,140	75.7	2,221
VHPR42-144	42	144	119	3	2	2	1-1/4	3/4	3/4	3/4	2,600	105	3,081
VHPR48-147	48	147	119	3	2	2	1-1/4	3/4	3/4	3/4	2,965	139	4,079
VHPR48-195	48	195	167	4	2	2	1-1/4	3/4	3/4	3/4	3,780	192	5,634
VHPR54-150	54	150	119	4	2	2	1-1/4	3/4	3/4	3/4	4,435	185	5,429
VHPR54-198	54	198	167	4	2-1/2	2-1/2	1-1/4	3/4	3/4	3/4	5,650	245	7,189
VHPR60-153	60	153	119	4	2-1/2	2-1/2	1-1/4	3/4	1	3/4	5,150	231	6,778
VHPR60-201	60	201	167	4	3	3	1-1/4	3/4	1	3/4	6,400	305	8,950
VHPR72-159	72	159	119	5	3	3	1-1/4	3/4	1	3/4	7,940	343	10,065
VHPR72-207	72	207	167	5	4	4	1-1/4	3/4	1	3/4	9,950	450	13,205
VHPR84-165	84	165	119	5	4	4	1-1/4	3/4	1	3/4	9,990	478	14,026
VHPR84-213	84	213	167	6	4	4	1-1/4	3/4	1	3/4	12,400	625	18,340
VHPR96-171	96	171	119	6	4	4	1-1/4	3/4	1	3/4	12,765	646	18,956
VHPR96-219	96	219	167	6	5	5	1-1/4	3/4	1	3/4	15,600	834	24,473
VHPR108-177	108	177	119	6	5	5	1-1/4	3/4	1	3/4	16,610	826	24,238
VHPR108-225	108	225	167	8	5	5	1-1/4	3/4	1-1/4	3/4	20,220	1,075	31,545
VHPR120-183	120	183	119	8	5	5	1-1/4	3/4	1-1/4	3/4	25,200	1,046	30,694
VHPR120-231	120	231	167	8	6	6	1-1/4	3/4	1-1/4	3/4	30,700	1,354	39,732
VHPR144-195	144	195	119	10	6	6	1-1/4	3/4	1-1/4	3/4	35,600	1,583	46,452
VHPR144-243	144	243	167	10	6	6	1-1/4	3/4	1-1/4	3/4	42,180	2,035	59,715

Notes: All dimensions are given in inches.
Pumpdown capacity is given in lbs of R-717 at 80% full and +95°F
Consult factory for certified drawings.



Vertical High Pressure / Thermosyphon Receivers 250# DWP

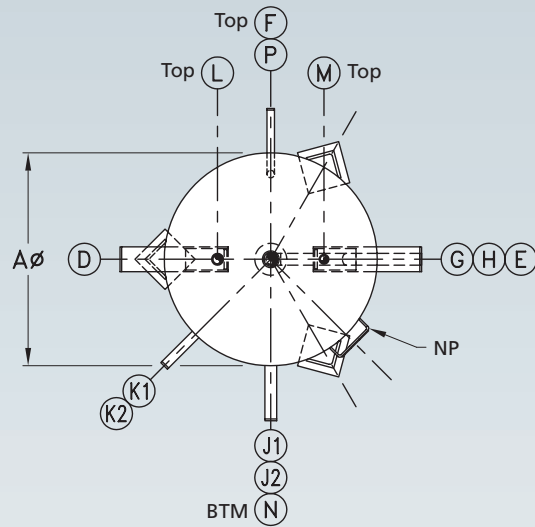
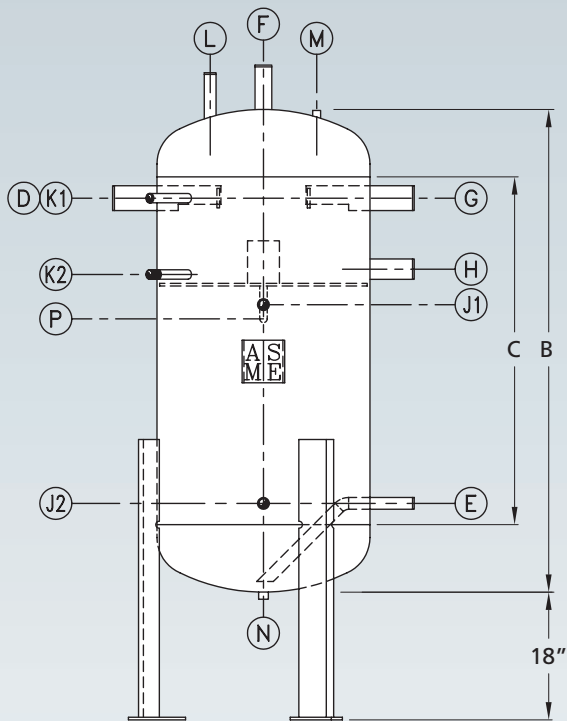

4 Legs required on vessels 84" O.D. and above.

Model No.	A Diameter	B Overall Length	C Shell Length	D Liquid Inlet	E Liquid Outlet	F Equalizer	G Thermo Return	H Thermo Supply	J Level Column	K TS Level Column	L Purge	M Relief	N Drain	P Thermo Drain	(lbs.) Vessel Weight	(Ft ³) Lower Internal Volume	(lbs. @ 100%) Pumpdown Capacity	(Ft ³) Upper Internal Volume
VHP/TSR-36-141	36	141	119	2-1/2	1-1/2	1-1/4	3	2-1/2	1-1/4	1	3/4	3/4	3/4	3/4	2,600	60	2,201	10
VHP/TSR48-195	48	195	167	4	2	3	4	3	1-1/4	1	3/4	3/4	3/4	3/4	4,200	155	5,685	18
VHP/TSR54-198	54	198	167	4	2-1/2	3	4	3	1-1/4	1	3/4	3/4	3/4	3/4	6,200	196	7,189	23
VHP/TSR60-201	60	201	167	4	3	3	4	3	1-1/4	1	3/4	1	3/4	3/4	7,100	243	8,899	29
VHP/TSR72-207	72	207	167	5	4	4	5	4	1-1/4	1	3/4	1	3/4	3/4	9,970	335	12,288	42
VHP/TSR84-213	84	213	167	6	4	5	6	5	1-1/4	1	3/4	1	3/4	3/4	12,900	470	17,240	57
VHP/TSR96-219	96	219	167	6	5	5	6	5	1-1/4	1	3/4	1	3/4	3/4	15,600	595	21,825	75
VHP/TSR108-225	108	225	167	8	5	6	8	6	1-1/4	1	3/4	1-1/4	3/4	3/4	20,750	756	27,730	95
VHP/TSR120-231	120	231	167	8	6	6	8	6	1-1/4	1	3/4	1-1/4	3/4	3/4	32,200	930	34,112	117
VHP/TSR144-243	144	243	167	10	6	8	10	8	1-1/4	1	3/4	1-1/4	3/4	3/4	44,100	1,345	49,335	169

Notes: All dimensions are given in inches.
 Pumpdown capacity (lower section) is given in lbs of R-717 at 100% full and +95°F
 Consult factory for certified drawings.

Horizontal Thermosyphon Receivers 250# DWP

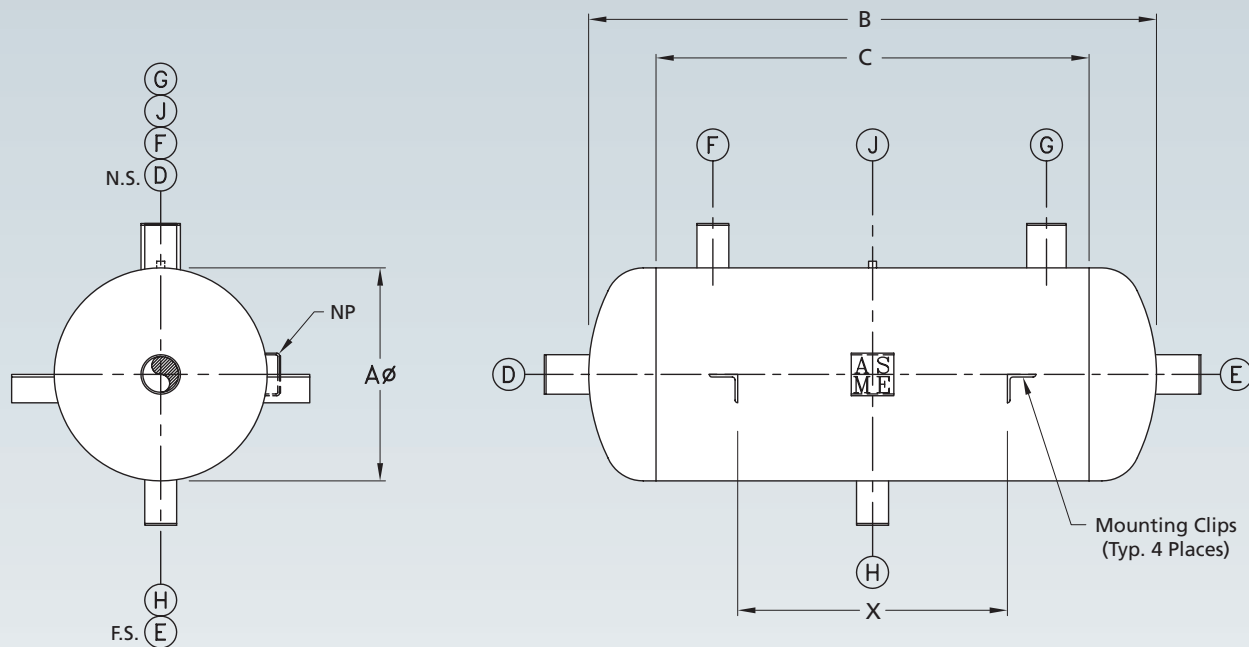

Model No.	Heat of Rejection MBH	A Diameter	B Overall Length	C Shell Length	D Liquid Inlet	E Liquid Outlet	F Equalizer	G Thermo Return	H Thermo Supply	J Relief	X Supports	(lbs.) Vessel Weight	(Ft ³) Internal Volume
HTSR8-48	113	8	48	40	1-1/2	1-1/2	1-1/4	1-1/4	1-1/4	1/2	22	165	1.5
HTSR10-48	173	10	48	38	2	2	1-1/4	2	1-1/4	1/2	22	220	2.4
HTSR12-48	244	12	48	37	2	2	1-1/2	2	1-1/2	1/2	22	290	2.9
HTSR12-72	377	12	72	61	2-1/2	2-1/2	2	2-1/2	2	1/2	32	395	4.4
HTSR16-72	619	16	72	59	3	3	2	3	2	1/2	32	410	7.8
HTSR20-72	968	20	72	57	4	4	3	4	3	1/2	32	640	12.1
HTSR24-72	1869	24	72	55-1/2	4	4	3	4	3	1/2	32	750	17.6
HTSR30-84	3420	30	84	65	5	5	4	5	4	1/2	38	1,090	32.2
HTSR36-96	5618	36	96	74	8	8	6	6	6	1/2	48	1,480	52.9
HTSR42-120	9622	42	120	95	8	8	8	8	8	1/2	55	2,250	90.6
HTSR48-147	15400	48	147	119	10	10	10	10	10	1/2	72	3,010	145

Notes: All dimensions are given in inches.
Heat of rejection is given in MBH at +96°F
Consult factory for certified drawings.



Vertical Thermosyphon Receivers 250# DWP

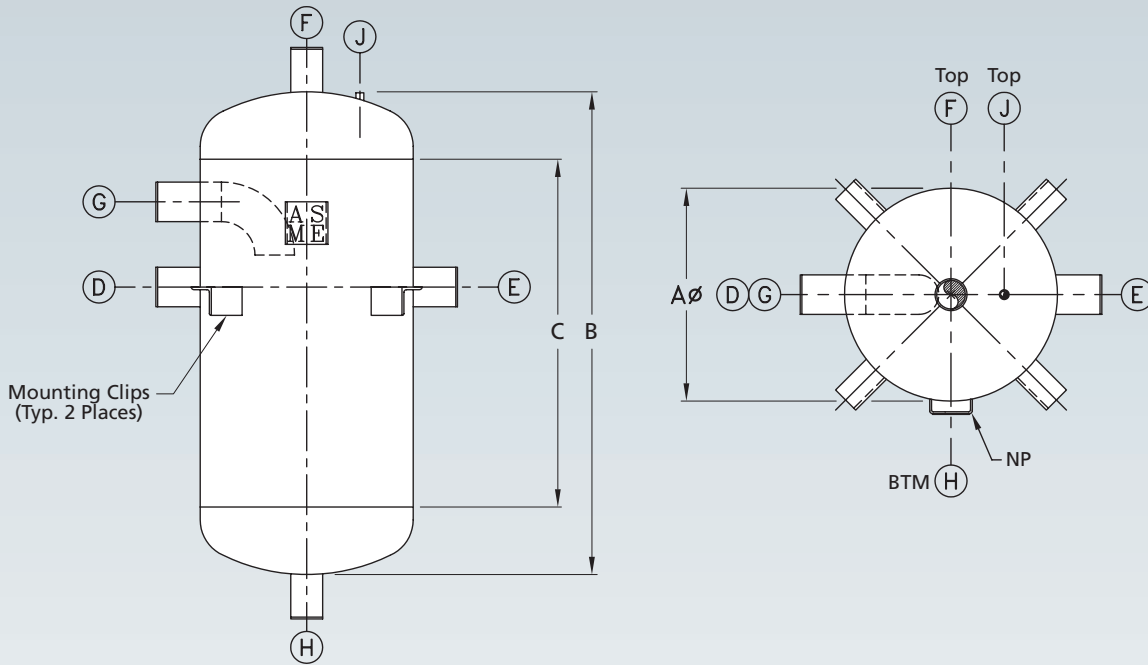

Model No.	Heat of Rejection MBH	A Diameter	B Overall Length	C Shell Length	D Liquid Inlet	E Liquid Outlet	F Equalizer	G Thermo Return	H Thermo Supply	J Relief	(lbs.) Vessel Weight	(Ft ³) Internal Volume
VTSR8-48	203	8	48	40	2	2	1 1/4	2	1-1/4	1/2	165	1.5
VTSR10-48	302	10	48	38	2-1/2	2-1/2	1 1/2	2	1-1/2	1/2	220	2.4
VTSR12-48	422	12	48	37	2-1/2	2-1/2	2	2-1/2	2	1/2	290	2.9
VTSR12-72	709	12	72	61	3	3	2-1/2	3	2-1/2	1/2	400	4.4
VTSR16-72	1111	16	72	59	4	4	3	4	3	1/2	510	7.8
VTSR20-72	1653	20	72	57	5	5	4	4	4	1/2	645	12.1
VTSR24-72	2148	24	72	55-1/2	5	5	4	5	4	1/2	750	17.6
VTSR30-84	4096	30	84	65	6	6	5	6	5	1/2	1,110	32.2

Notes: All dimensions are given in inches.
Heat of rejection is given in MBH at +96°F
Consult factory for certified drawings.

Vertical Control Pressure Receivers 250# DWP

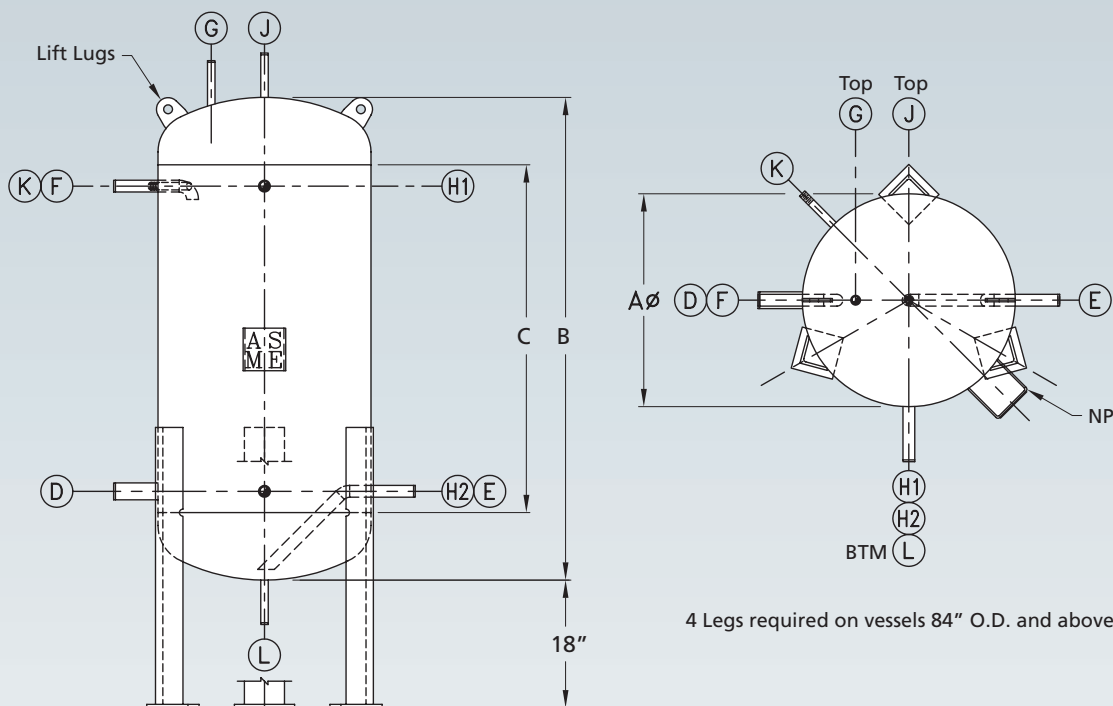

Model No.	A Diameter	B Overall Length	C Shell Length	D Liquid Transfer Inlet	E Liquid Outlet	F Liquid Inlet	G Gas Inlet/Outlet	H Level Column	J Relief	K Oil Pot Vent	L Drain	(lbs.) Vessel Weight	(Ft ³) Internal Volume	(lbs. @ 80%) Pumpdown Capacity
VCPR20-144	20	144	129	1-1/4	1-1/4	3/4	3/4	1-1/4	1-1/2	3/4	2	1,200	22.9	706
VCPR24-144	24	144	127-1/2	1-1/4	1-1/4	1	3/4	1-1/4	1-1/2	3/4	2	1,330	34.7	1,069
VCPR30-138	30	138	119	2	1-1/2	1-1/4	3/4	1-1/4	1-1/2	3/4	2	1,695	20.9	644
VCPR36-141	36	141	119	2	2	1-1/4	3/4	1-1/4	1-1/2	3/4	2	2,140	75.6	2,329
VCPR42-144	42	144	119	2	2	1-1/2	3/4	1-1/4	1-1/2	3/4	2	2,600	110	3,380
VCPR48-147	48	147	119	3	2-1/2	2	1-1/4	1-1/4	1-1/2	3/4	2	2,980	139	4,282
VCPR54-150	54	150	119	4	3	2	1-1/4	1-1/4	1-1/2	3/4	2	4,500	184	5,669
VCPR60-153	60	153	119	4	3	2	1-1/4	1-1/4	1-1/2	3/4	2	5,150	234	7,209
VCPR72-159	72	159	119	5	4	2-1/2	1-1/2	1-1/4	1-1/2	3/4	2	7,940	342	10,536
VCPR84-165	84	165	119	5	4	3	2	1-1/4	1-1/2	3/4	2	9,990	478	14,726
VCPR96-171	96	171	119	5	4	3	2	1-1/4	1-1/2	3/4	2	12,765	645	19,871

Notes: All dimensions are given in inches.
Pumpdown capacity is given in lbs of R-717 at 80% full and +60°F
Consult factory for certified drawings.



Vertical Pilot Receivers 250# DWP

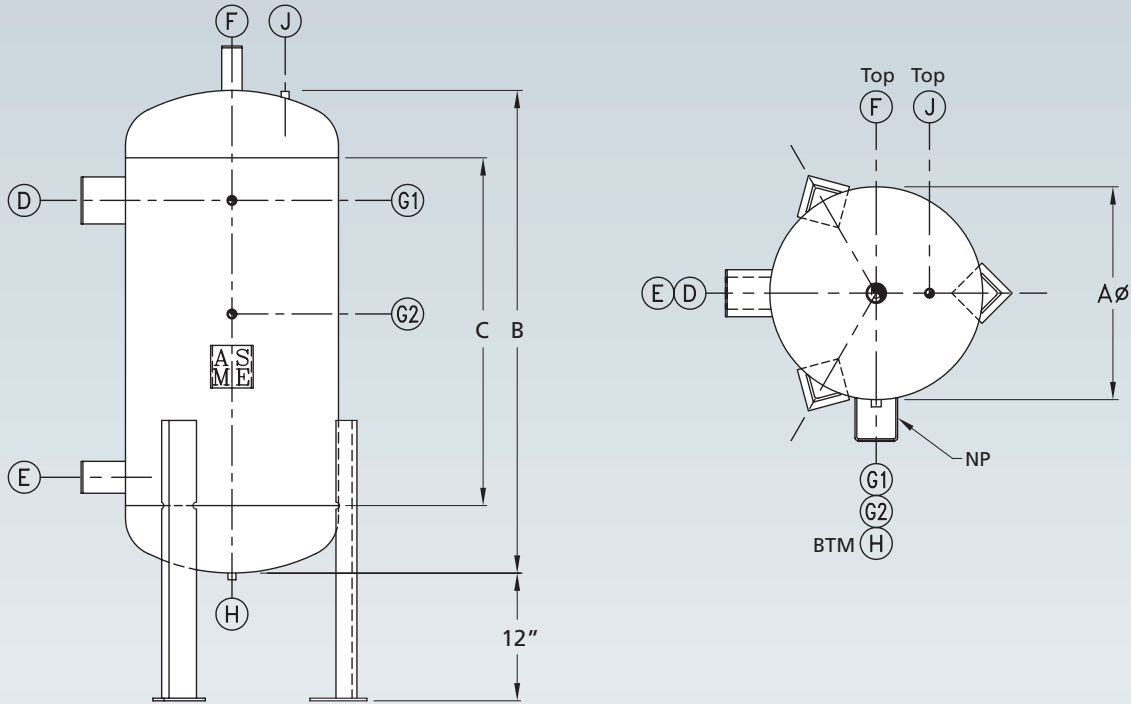

Model No.	A Diameter	B Overall Length	C Shell Length	D Liquid Inlet	E Liquid Outlet	F Vent	G Chamber Balance	H Drain	J Relief	(lbs.) Vessel Weight	(Ft ³) Internal Volume
VPR10-48	10	48	38	2	1	1-1/4	3/4	1/2	1/2	230	2.3
VPR12-48	12	48	37	3	1-1/2	2	3/4	1/2	1/2	300	2.9
VPR16-60	16	60	47	4	2	2-1/2	3/4	1/2	1/2	450	6.0
VPR20-60	20	60	45	6	3	4	3/4	1/2	1/2	600	9.4
VPR24-72	24	72	55-1/2	8	4	5	3/4	1/2	1/2	820	16.1

Notes: All dimensions are given in inches.
Consult factory for certified drawings.

Vertical Recirculators 250# DWP

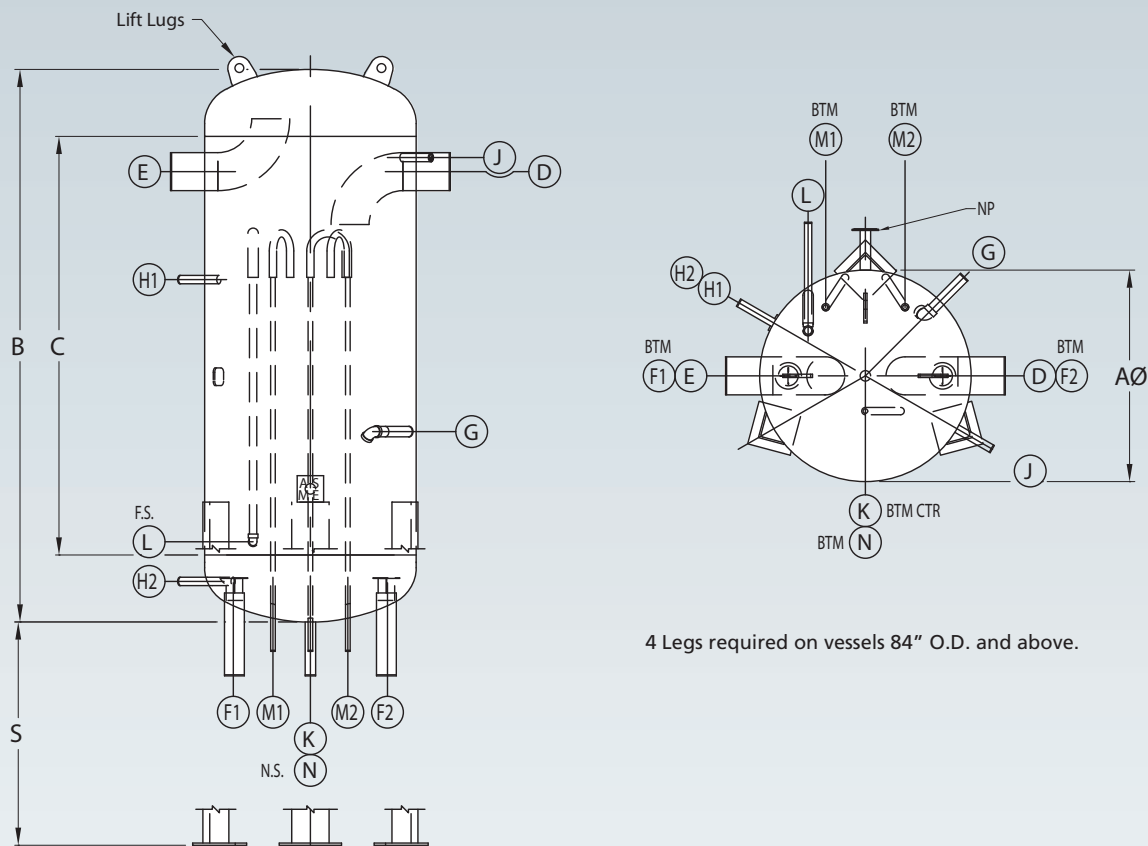

4 Legs required on vessels 84" O.D. and above.

Model No.	A Diameter	B Overall Length	C Shell Length	D Suction Inlet	E Gas Outlet	F Pump Suction(s)	G Liquid Make Up	H Level Column	J Relief	K Drain	L Minimum Flow	M Motor Cooling	N Oil Pot Vent	S Leg Height	(lbs.) Vessel Weight
VR24-112	24	112-1/2	96	5	4	4	1-1/4	1-1/2	1-1/2	2	1-1/4	3/4	3/4	58	1,460
VR30-115	30	115	96	6	5	4	1-1/4	1-1/2	1-1/2	2	1-1/4	3/4	3/4	60	1,760
VR36-118	36	118	96	6	6	4	1-1/2	1-1/2	1-1/2	2	1-1/4	3/4	3/4	60	2,285
VR42-144	42	144	119	8	6	4	2	1-1/2	1-1/2	2	1-1/4	3/4	3/4	60	3,010
VR48-147	48	147	119	8	8	5	2	1-1/2	1-1/2	2	1-1/2	3/4	3/4	64	3,080
VR54-150	54	150	119	10	8	5	2	1-1/2	1-1/2	2	1-1/2	3/4	3/4	64	5,045
VR60-153	60	153	119	10	8	6	2-1/2	1-1/2	1-1/2	2	1-1/2	3/4	3/4	64	5,675
VR72-159	72	159	119	12	10	6	3	1-1/2	1-1/2	2	1-1/2	3/4	3/4	72	8,845
VR84-165	84	165	119	12	10	8	3	1-1/2	1-1/2	2	1-1/2	3/4	3/4	72	11,635
VR96-171	96	171	119	14	12	8	4	1-1/2	1-1/2	2	1-1/2	3/4	3/4	72	13,325
VR108-177	108	177	119	16	12	(3) 6	4	1-1/2	1-1/2	2	3	(3) 3/4	3/4	72	18,577
VR120-183	120	183	119	16	14	(3) 8	4	1-1/2	1-1/2	2	3	(3) 3/4	3/4	72	26,700
VR144-195	144	195	119	20	16	(4) 8	5	1-1/2	1-1/2	2	4	(4) 3/4	3/4	72	38,940

Notes: All dimensions are given in inches.
 Consult factory for certified drawings.
 See RVS Bulletin 506 MRP Matrix Recirculator Package for capacities.



Horizontal Recirculators 250# DWP

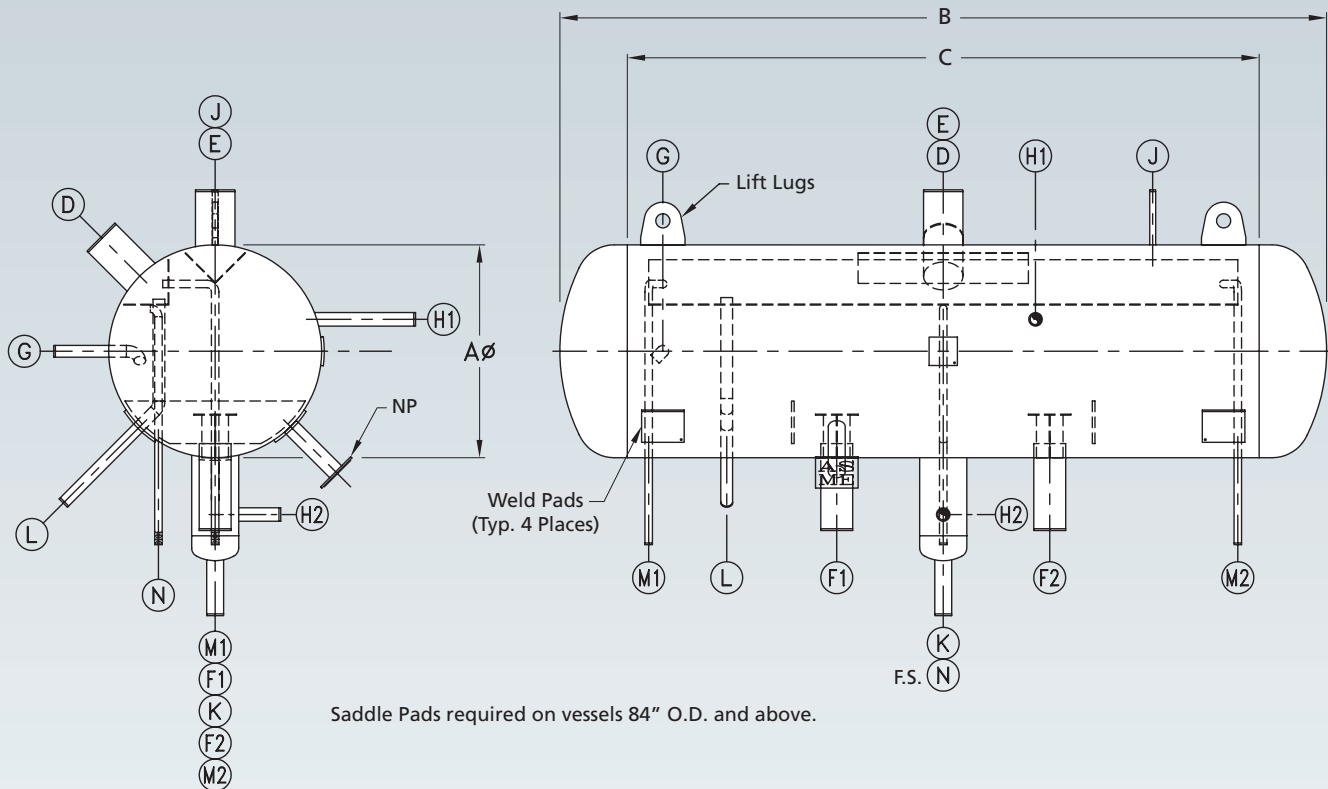

Model No.	A Diameter	B Overall Length	C Shell Length	D Suction Inlet	E Gas Outlet	F Pump Suction(s)	G Liquid Make Up	H Level Column	J Relief	K Drain	L Minimum Flow	M Motor Cooling	N Oil Pot Vent	(lbs.) Vessel Weight
HR24-135	24	135-1/2	119	4	4	4	1	1-1/2	1-1/2	2	1-1/4	3/4	3/4	1,405
HR30-138	30	138	119	5	5	4	1-1/4	1-1/2	1-1/2	2	1-1/4	3/4	3/4	1,760
HR36-141	36	141	119	6	5	4	1-1/2	1-1/2	1-1/2	2	1-1/4	3/4	3/4	2,115
HR42-144	42	144	119	8	6	4	2	1-1/2	1-1/2	2	1-1/4	3/4	3/4	2,540
HR48-147	48	147	119	8	8	5	2	1-1/2	1-1/2	2	1-1/2	3/4	3/4	2,980
HR54-150	54	150	119	8	8	5	2	1-1/2	1-1/2	2	1-1/2	3/4	3/4	4,375
HR60-153	60	153	119	10	8	6	2-1/2	1-1/2	1-1/2	2	1-1/2	3/4	3/4	5,020
HR72-159	72	159	119	10	10	6	2-1/2	1-1/2	1-1/2	2	1-1/2	3/4	3/4	7,675
HR84-165	84	165	119	12	10	8	3	1-1/2	1-1/2	2	1-1/2	3/4	3/4	10,040
HR96-171	96	171	119	14	12	8	3	1-1/2	1-1/2	2	1-1/2	3/4	3/4	15,534
HR108-177	108	177	119	16	12	(3) 6	4	1-1/2	1-1/2	2	3	(3) 3/4	3/4	18,058
HR120-183	120	183	119	16	14	(3) 8	4	1-1/2	1-1/2	2	3	(3) 3/4	3/4	26,586
HR144-195	144	195	119	20	16	(4) 8	5	1-1/2	1-1/2	2	4	(3) 3/4	3/4	34,390

Notes: All dimensions are given in inches.
 Consult factory for certified drawings.
 See RVS Bulletin 506 MRP Matrix Recirculator Package for capacities.

Vertical Intercoolers 250# DWP

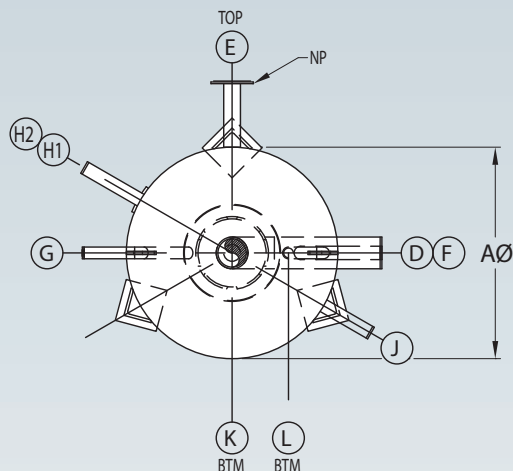
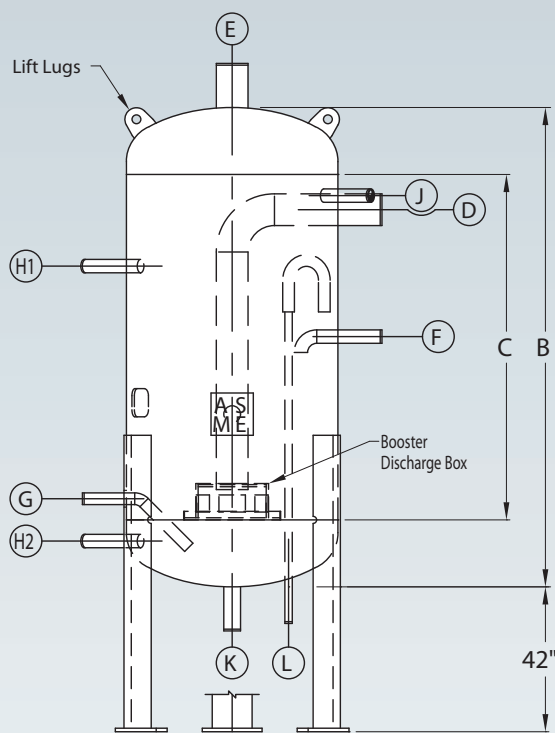

4 Legs required on vessels 84" O.D. and above.

Model No.	A Diameter	B Overall Length	C Shell Length	D Booster Inlet	E Gas Outlet	F Liquid Make-Up	G Liquid Outlet	H Level Column	J Relief	K Drain	L Oil Pot Vent	(lbs.) Vessel Weight
VI16-96	16	96	83	3	3	1	1	1-1/2	1-1/2	2	3/4	730
VI20-108	20	108	93	3	3	1	1	1-1/2	1-1/2	2	3/4	1,120
VI24-112	24	112-1/2	96	4	4	1	1	1-1/2	1-1/2	2	3/4	1,365
VI30-115	30	115	96	5	5	1-1/4	1-1/4	1-1/2	1-1/2	2	3/4	1,730
VI36-118	36	118	96	6	6	1-1/2	1-1/2	1-1/2	1-1/2	2	3/4	2,240
VI42-144	42	144	119	6	6	2	2	1-1/2	1-1/2	2	3/4	2,975
VI48-147	48	147	119	8	8	2	2	1-1/2	1-1/2	2	3/4	3,295
VI54-150	54	150	119	8	8	2	2	1-1/2	1-1/2	2	3/4	4,750
VI60-153	60	153	119	8	8	2-1/2	2-1/2	1-1/2	1-1/2	2	3/4	5,430
VI72-159	72	159	119	10	10	3	3	1-1/2	1-1/2	2	3/4	8,600
VI84-165	84	165	119	10	10	3	3	1-1/2	1-1/2	2	3/4	10,575
VI96-171	96	171	119	12	12	4	4	1-1/2	1-1/2	2	3/4	13,700
VI108-177	108	177	119	12	12	4	4	1-1/2	1-1/2	2	3/4	17,950
VI120-183	120	183	119	14	14	4	4	1-1/2	1-1/2	2	3/4	27,650
VI144-195	144	195	119	16	16	5	5	1-1/2	1-1/2	2	3/4	38,325

Notes: All dimensions are given in inches.
 Consult factory for certified drawings.
 See RVS Bulletin 510 MVI Intercooler Package for capacities.



Vertical Intercoolers with Coil 250# DWP

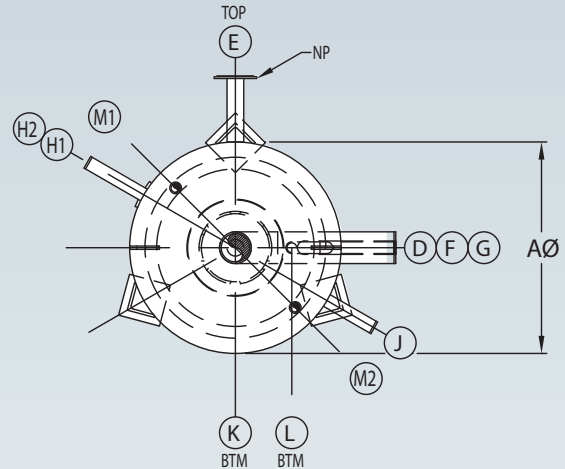
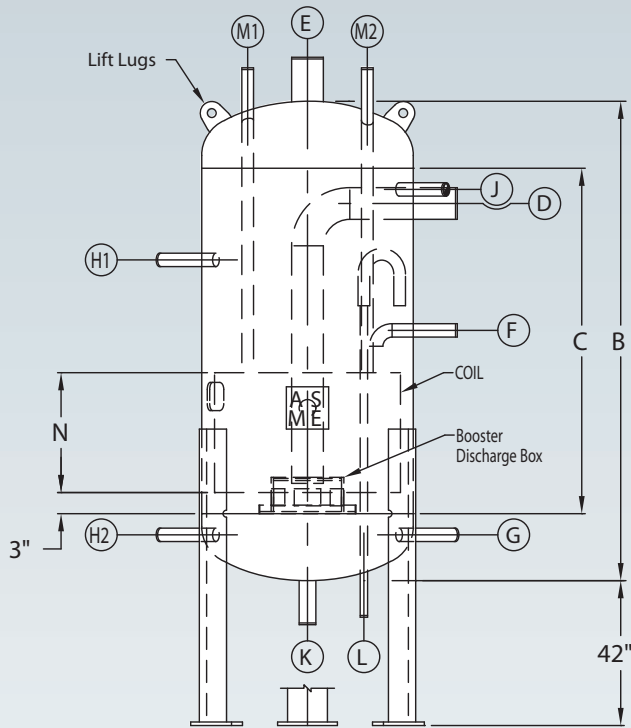

4 Legs required on vessels 84" O.D. and above.

Model No.	A Diameter	B Overall Length	C Shell Length	D Booster Inlet	E Gas Outlet	F Liquid Make-Up	G Liquid Outlet	H Level Column	J Relief	K Drain	L Oil Pot Vent	(feet) Coil Linear Feet	M Coil In/Out	N Coil Height	(lbs.) Vessel Weight
VIC16-96	16	96	83	3	3	1	1	1-1/2	1-1/2	2	3/4	75	3/4	28	858
VIC20-108	20	108	93	3	3	1	1	1-1/2	1-1/2	2	3/4	116	3/4	20	1,305
VIC24-112	24	112-1/2	96	4	4	1	1	1-1/2	1-1/2	2	3/4	139	1	30	1,688
VIC30-115	30	115	96	5	5	1-1/4	1-1/4	1-1/2	1-1/2	2	3/4	173	1-1/4	30	2,262
VIC36-118	36	118	96	6	6	1-1/2	1-1/2	1-1/2	1-1/2	2	3/4	220	1-1/2	36	3,071
VIC42-144	42	144	119	6	6	2	2	1-1/2	1-1/2	2	3/4	294	1-1/2	38	4,112
VIC48-147	48	147	119	8	8	2	2	1-1/2	1-1/2	2	3/4	385	1-1/2	30	4,731
VIC54-150	54	150	119	8	8	2	2	1-1/2	1-1/2	2	3/4	395	2	36	6,500
VIC60-153	60	153	119	8	8	2-1/2	2-1/2	1-1/2	1-1/2	2	3/4	491	2	36	7,690
VIC72-159	72	159	119	10	10	3	3	1-1/2	1-1/2	2	3/4	630	3	36	11,125
VIC84-165	84	165	119	10	10	3	3	1-1/2	1-1/2	2	3/4	857	3	42	14,465
VIC96-171	96	171	119	12	12	4	4	1-1/2	1-1/2	2	3/4	1,128	4	36	18,700
VIC108-177	108	177	119	12	12	4	4	1-1/2	1-1/2	2	3/4	1,424	4	42	24,270
VIC120-183	120	183	119	14	14	4	4	1-1/2	1-1/2	2	3/4	1,758	5	48	35,450
VIC144-195	144	195	119	16	16	5	5	1-1/2	1-1/2	2	3/4	2,471	6	42	49,295

Notes: All dimensions are given in inches.
 Consult factory for certified drawings.
 See RVS Bulletin 510 MVI Intercooler Package for capacities.

Horizontal Accumulators 250# DWP

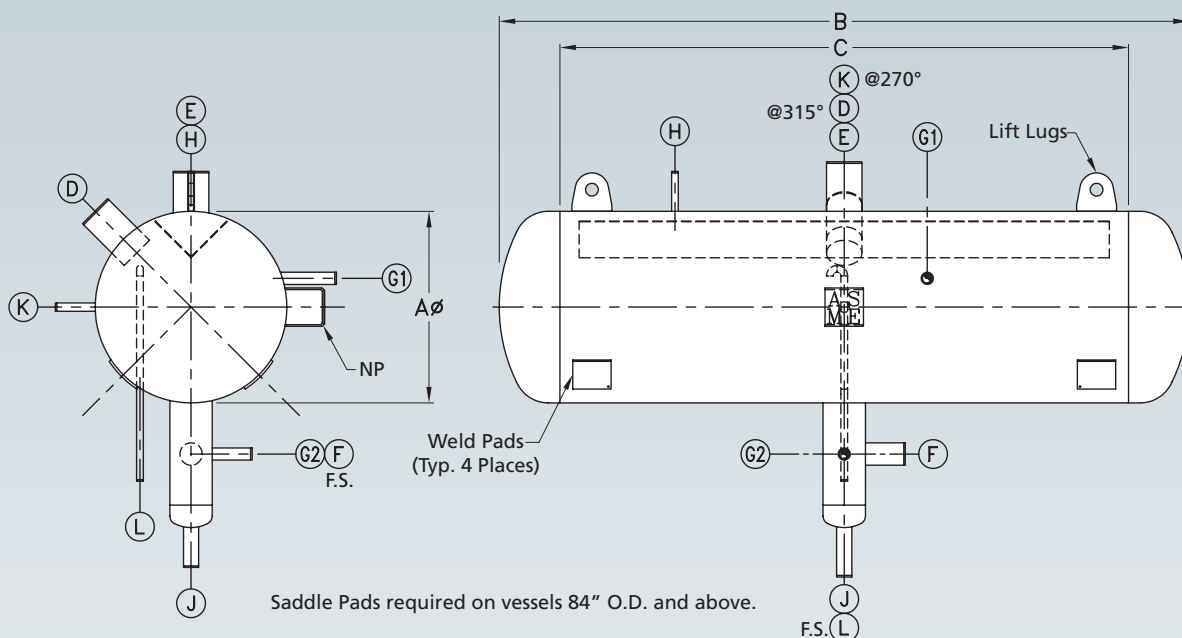

Saddle Pads required on vessels 84" O.D. and above.

Model No.	A Diameter	B Overall Length	C Shell Length	D Suction Inlet	E Gas Outlet	F Liquid Outlet(s)	G Level Column	H Relief	J Drain	K 3 Way Vent(s)	L Oil Pot Vent	(lbs.) Vessel Weight
HA24-135	24	135-1/2	119	4	4	3	1-1/2	1-1/2	2	1-1/4	3/4	1,330
HA30-138	30	138	119	5	5	3	1-1/2	1-1/2	2	1-1/4	3/4	1,735
HA36-141	36	141	119	6	5	4	1-1/2	1-1/2	2	1-1/4	3/4	2,460
HA42-144	42	144	119	8	6	4	1-1/2	1-1/2	2	1-1/4	3/4	2,560
HA48-147	48	147	119	8	8	4	1-1/2	1-1/2	2	1-1/4	3/4	3,030
HA54-150	54	150	119	8	8	4	1-1/2	1-1/2	2	1-1/4	3/4	4,480
HA60-153	60	153	119	10	8	(2) 4	1-1/2	1-1/2	2	(2) 1-1/4	3/4	5,220
HA72-159	72	159	119	10	10	(2) 4	1-1/2	1-1/2	2	(2) 1-1/4	3/4	8,020
HA84-165	84	165	119	12	10	(2) 4	1-1/2	1-1/2	2	(2) 1-1/4	3/4	10,020
HA96-171	96	171	119	14	12	(2) 4	1-1/2	1-1/2	2	(2) 1-1/4	3/4	12,900
HA108-177	108	177	119	16	12	(2) 4	1-1/2	1-1/2	2	(2) 1-1/4	3/4	16,685
HA120-183	120	183	119	16	14	(2) 4	1-1/2	1-1/2	2	(2) 1-1/4	3/4	25,600
HA144-195	144	195	119	20	16	(2) 4	1-1/2	1-1/2	2	(2) 1-1/4	3/4	35,130

Notes: All dimensions are given in inches.
Consult factory for certified drawings.

Horizontal Accumulator Capacity—Tons of Refrigeration R-717

Model No.	Evaporator Temperature °F									
	Single Stage*					Two Stage**				
	30°F	20°F	10°F	0°F	-10°F	-20°F	-20°F	-30°F	-40°F	-50°F
HA24-135	113	103	91	82	71	62	73	62	53	44
HA30-138	188	172	154	137	120	104	122	104	88	74
HA36-141	284	259	233	206	181	156	184	157	133	111
HA42-144	399	363	327	290	254	219	258	221	187	156
HA48-147	533	486	436	387	339	293	345	295	250	209
HA54-150	680	619	556	493	432	374	440	376	318	267
HA60-153	852	775	697	618	541	468	551	472	399	334
HA72-159	1,244	1,133	1,018	903	791	684	805	689	583	488
HA84-165	1,721	1,567	1,408	1,249	1,094	946	1,114	953	807	676
HA96-171	2,275	2,072	1,862	1,651	1,446	1,251	1,473	1,260	1,067	893
HA108-177	2,893	2,634	2,367	2,099	1,839	1,591	1,872	1,602	1,356	1,136
HA120-183	3,569	3,250	2,920	2,590	2,269	1,963	2,310	1,976	1,673	1,401
HA144-195	5,207	4,742	4,261	3,780	3,311	2,864	3,370	2,885	2,442	2,045

* Single stage capacities based on +96°F liquid supply temperature.

** Two stage capacities based on +25°F liquid supply temperature.



Vertical Accumulators 250# DWP

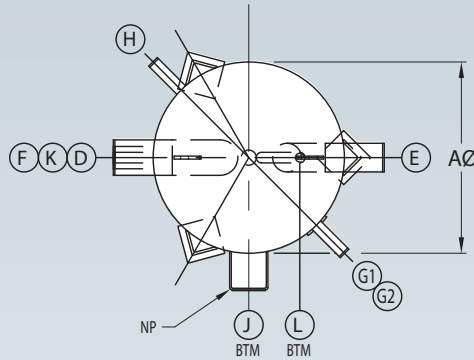
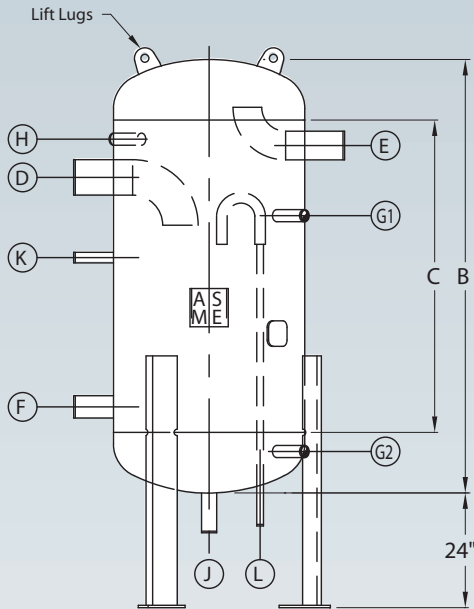

4 Legs required on vessels 84" O.D. and above.

Model No.	A Diameter	B Overall Length	C Shell Length	D Suction Inlet	E Gas Outlet	F Liquid Outlet(s)	G Level Column	H Relief	J Drain	K 3 Way Vent(s)	L Oil Pot Vent	(lbs.) Vessel Weight
VA12-72	12	72	61	2-1/2	2-1/2	2	1-1/2	1-1/2	2	3/4	3/4	550
VA16-85	16	85	72	3	3	2	1-1/2	1-1/2	2	3/4	3/4	640
VA20-87	20	87	72	4	4	3	1-1/2	1-1/2	2	3/4	3/4	880
VA24-88	24	88-1/2	72	5	4	3	1-1/2	1-1/2	2	1-1/4	3/4	1,070
VA30-115	30	115	96	6	5	3	1-1/2	1-1/2	2	1-1/4	3/4	1,585
VA36-118	36	118	96	6	6	4	1-1/2	1-1/2	2	1-1/4	3/4	2,040
VA42-121	42	121	96	8	6	4	1-1/2	1-1/2	2	1-1/4	3/4	2,435
VA48-147	48	147	119	8	8	4	1-1/2	1-1/2	2	1-1/4	3/4	3,300
VA54-150	54	150	119	10	8	4	1-1/2	1-1/2	2	1-1/4	3/4	4,750
VA60-153	60	153	119	10	8	(2) 4	1-1/2	1-1/2	2	(2) 1-1/4	3/4	5,365
VA72-159	72	159	119	12	10	(2) 4	1-1/2	1-1/2	2	(2) 1-1/4	3/4	8,380
VA84-165	84	165	119	12	10	(2) 4	1-1/2	1-1/2	2	(2) 1-1/4	3/4	10,770
VA96-171	96	171	119	14	12	(2) 4	1-1/2	1-1/2	2	(2) 1-1/4	3/4	13,680
VA108-177	108	177	119	16	12	(2) 4	1-1/2	1-1/2	2	(2) 1-1/4	3/4	17,381
VA120-183	120	183	119	16	14	(2) 4	1-1/2	1-1/2	2	(2) 1-1/4	3/4	26,500
VA144-195	144	195	119	20	16	(2) 4	1-1/2	1-1/2	2	(2) 1-1/4	3/4	36,725

Notes: All dimensions are given in inches. Consult factory for certified drawings.

Vertical Accumulator Capacity—Tons of Refrigeration R-717

Model No.	Evaporator Temperature °F									
	Single Stage*						Two Stage**			
	30°F	20°F	10°F	0°F	-10°F	-20°F	-20°F	-30°F	-40°F	-50°F
VA12-72	38	35	31	27	24	21	24	21	18	15
VA16-85	62	56	50	45	39	34	40	34	29	24
VA20-87	99	90	81	72	63	54	64	55	46	38
VA24-88	144	131	118	105	92	79	93	80	67	56
VA30-115	229	208	187	166	145	126	148	126	107	90
VA36-118	332	303	272	241	211	183	215	184	156	130
VA42-121	455	415	373	330	289	250	295	252	213	179
VA48-147	598	544	489	434	380	328	387	331	280	234
VA54-150	752	685	615	546	478	413	487	416	352	295
VA60-153	932	849	763	676	592	512	603	516	437	366
VA72-159	1,340	1,221	1,097	973	852	737	867	742	628	526
VA84-165	1,834	1,670	1,501	1,331	1,166	1,008	1,187	1,016	860	720
VA96-171	2,404	2,190	1,968	1,745	1,529	1,322	1,556	1,332	1,127	944
VA108-177	3,038	2,767	2,486	2,205	1,931	1,671	1,966	1,683	1,424	1,193
VA120-183	3,729	3,396	3,052	2,707	2,371	2,051	2,414	2,066	1,749	1,465
VA144-195	5,401	4,919	4,420	3,920	3,434	2,971	3,496	2,992	2,532	2,121

* Single stage capacities based on +96°F liquid supply temperature.

** Two stage capacities based on +25°F liquid supply temperature.

Vertical Accumulators with Coil 250# DWP

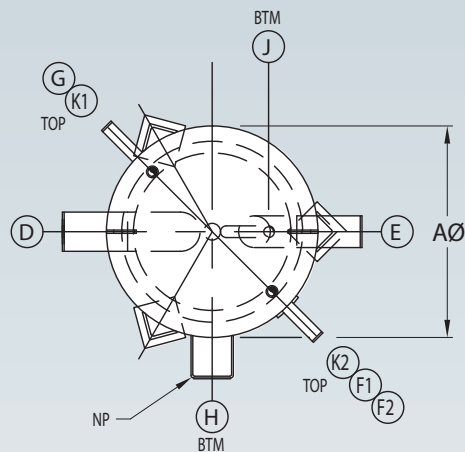
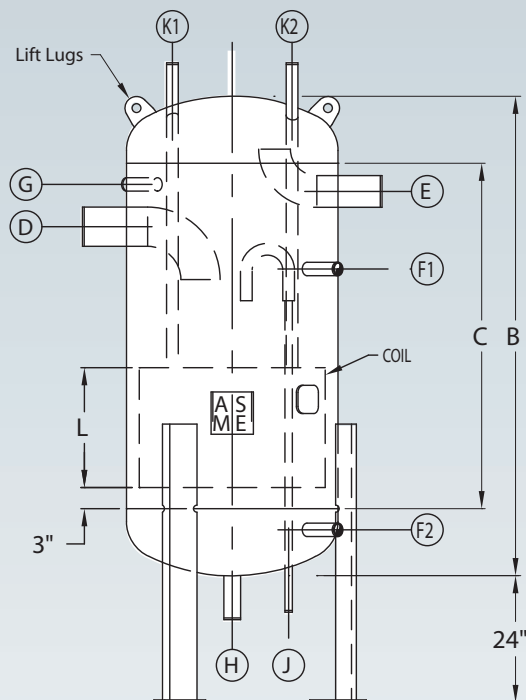

4 Legs required on vessels 84" O.D. and above.

Model No.	A Diameter	B Overall Length	C Shell Length	D Suction Inlet	E Gas Outlet	F Level Column	G Relief	H Drain	J Oil Pot Vent	(feet) Coil Linear Feet	K Coil In/Out	L Coil Height	(lbs.) Vessel Weight
VAC16-85	16	85	72	3	3	1-1/2	1-1/2	2	3/4	56	3/4	22	739
VAC20-87	20	87	72	4	4	1-1/2	1-1/2	2	3/4	71	1	25	1,064
VAC24-88	24	88-1/2	72	5	4	1-1/2	1-1/2	2	3/4	81	1-1/4	34	1,364
VAC30-115	30	115	96	6	5	1-1/2	1-1/2	2	3/4	128	1-1/4	38	2,019
VAC36-118	36	118	96	6	6	1-1/2	1-1/2	2	3/4	160	1-1/2	42	2,684
VAC42-121	42	121	96	8	6	1-1/2	1-1/2	2	3/4	218	1-1/2	34	3,258
VAC48-147	48	147	119	8	8	1-1/2	1-1/2	2	3/4	227	2	30	4,186
VAC54-150	54	150	119	10	8	1-1/2	1-1/2	2	3/4	289	2	36	5,858
VAC60-153	60	153	119	10	8	1-1/2	1-1/2	2	3/4	356	2	36	6,710
VAC72-159	72	159	119	12	10	1-1/2	1-1/2	2	3/4	516	3	34	10,263
VAC84-165	84	165	119	12	10	1-1/2	1-1/2	2	3/4	700	3	36	13,427
VAC96-171	96	171	119	14	12	1-1/2	1-1/2	2	3/4	918	4	40	17,292
VAC108-177	108	177	119	16	12	1-1/2	1-1/2	2	3/4	1,159	4	36	21,926
VAC120-183	120	183	119	16	14	1-1/2	1-1/2	2	3/4	1,429	5	36	32,090
VAC144-195	144	195	119	20	16	1-1/2	1-1/2	2	3/4	2,061	6	36	44,762

Notes: All dimensions are given in inches.
Consult factory for certified drawings.



Vertical Surge Drums 250# DWP

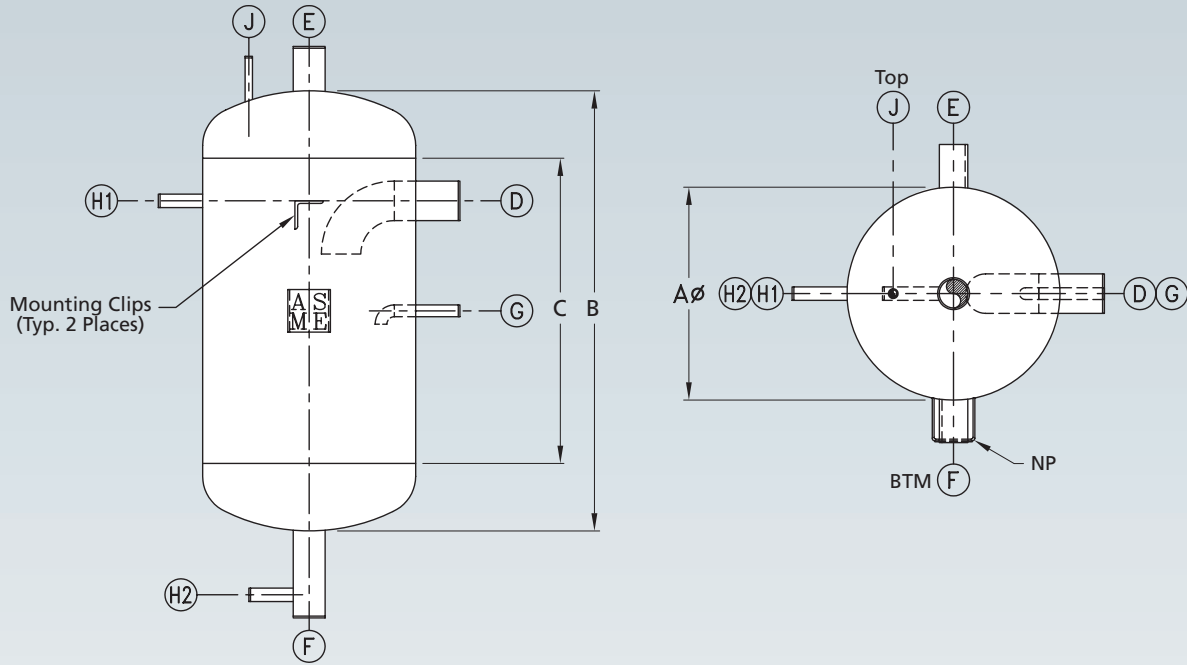

Model No.	A Diameter	B Overall Length	C Shell Length	D Suction Inlet	E Gas Outlet	F Liquid Outlet	G Liquid Make-Up	H Level Column	J Relief	(Ft ³) Surge Volume	(lbs.) Vessel Weight
VSD12-48	12	48	37	2-1/2	2-1/2	2-1/2	3/4	1-1/2	1-1/2	1.5	295
VSD16-54	16	54	41	3	3	3	3/4	1-1/2	1-1/2	2.7	395
VSD20-60	20	60	45	4	4	4	1	1-1/2	1-1/2	4.8	545
VSD24-60	24	60	43-1/2	5	4	5	1-1/4	1-1/2	1-1/2	6.8	660
VSD30-72	30	72	53	6	5	6	1-1/2	1-1/2	1-1/2	13.7	1175
VSD36-78	36	78	56	8	5	8	2	1-1/2	1-1/2	19.6	1,370
VSD42-84	42	84	59	8	6	8	2	1-1/2	1-1/2	30	1,630

Notes: All dimensions are given in inches.
Surge volume calculated between 6" OPL and HLCO 6" below suction inlet elbow.
Consult factory for certified drawings.

Vertical Surge Drum Capacity—Tons of Refrigeration R-717

Model No.	Evaporator Temperature °F									
	Single Stage*						Two Stage**			
	30°F	20°F	10°F	0°F	-10°F	-20°F	-20°F	-30°F	-40°F	-50°F
VSD12-48	38	35	31	27	24	21	24	21	18	15
VSD16-54	62	56	50	45	39	34	40	34	29	24
VSD20-60	99	90	81	72	63	54	64	55	46	38
VSD24-60	144	131	118	105	92	79	93	80	67	56
VSD30-72	229	208	187	166	145	126	148	126	107	90
VSD36-78	332	303	272	241	211	183	215	184	156	130
VSD42-84	455	415	373	330	289	250	295	252	213	179

* Single stage capacities based on +96°F liquid supply temperature.

** Two stage capacities based on +25°F liquid supply temperature.

Horizontal Surge Drums 250# DWP

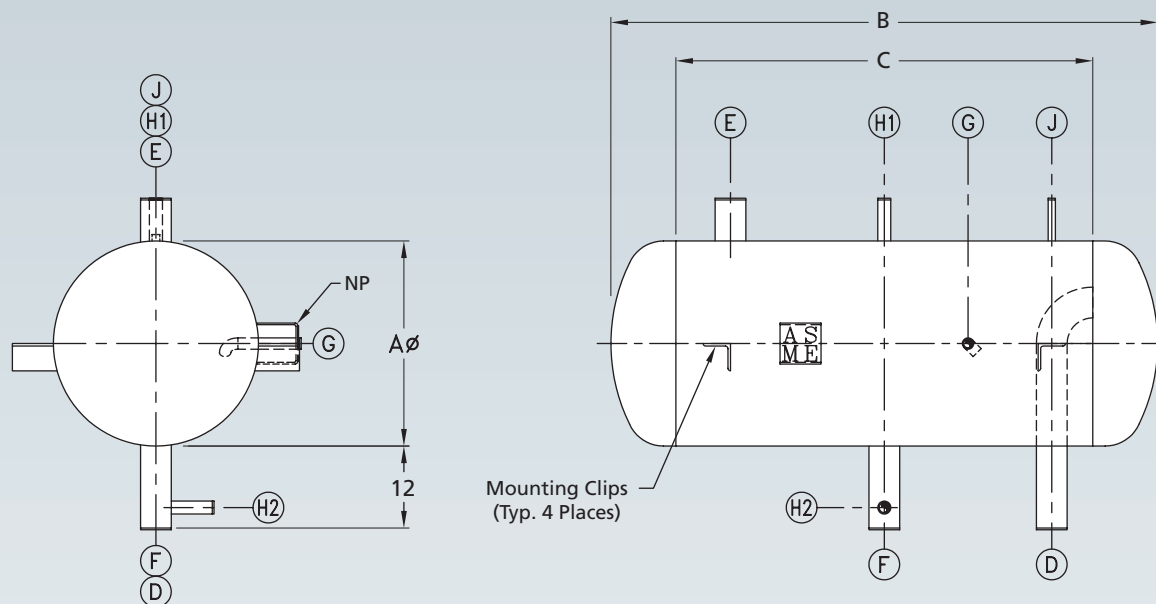

Model No.	A Diameter	B Overall Length	C Shell Length	D Suction Inlet	E Gas Outlet	F Liquid Outlet	G Liquid Make-Up	H Level Column	J Relief	(F ³) Surge Volume	(lbs.) Vessel Weight
HSD12-48	12	48	37	2-1/2	1-1/2	2-1/2	3/4	1-1/2	1-1/2	1.1	295
HSD16-60	16	60	47	3	2	3	3/4	1-1/2	1-1/2	2.9	450
HSD20-72	20	72	57	4	2-1/2	4	3/4	1-1/2	1-1/2	5.9	650
HSD24-72	24	72	55-1/2	4	3	4	3/4	1-1/2	1-1/2	8.7	775
HSD30-96	30	96	77	5	4	5	1-1/4	1-1/2	1-1/2	18	1,250
HSD36-96	36	96	74	6	4	6	1-1/4	1-1/2	1-1/2	26	1,860
HSD42-120	42	120	95	8	5	8	1-1/2	1-1/2	1-1/2	45	2,250

Notes: All dimensions are given in inches.
Surge volume calculated between 4" OPL and HLCO 2" above center line.
Consult factory for certified drawings.

Horizontal Surge Drum Capacity—Tons of Refrigeration R-717

Model No.	Evaporator Temperature °F									
	Single Stage*					Two Stage**				
	30°F	20°F	10°F	0°F	-10°F	-20°F	-20°F	-30°F	-40°F	-50°F
HSD12-48	12.0	11.0	10.0	9.2	8.0	6.9	8.2	7.0	5.9	4.9
HSD16-60	20	19	17	15	13	11	13	11	9.7	8.1
HSD20-72	36	33	29	26	23	20	23	20	17	14
HSD24-72	56	51	46	41	35	31	36	31	26	22
HSD30-96	94	86	77	68	60	52	61	52	44	37
HSD36-96	142	129	116	103	90	78	92	78	66	55
HSD42-120	199	181	163	145	127	110	129	110	93	78

* Single stage capacities based on +96°F liquid supply temperature.
** Two stage capacities based on +25°F liquid supply temperature.



Split Flow Horizontal Surge Drums 250# DWP

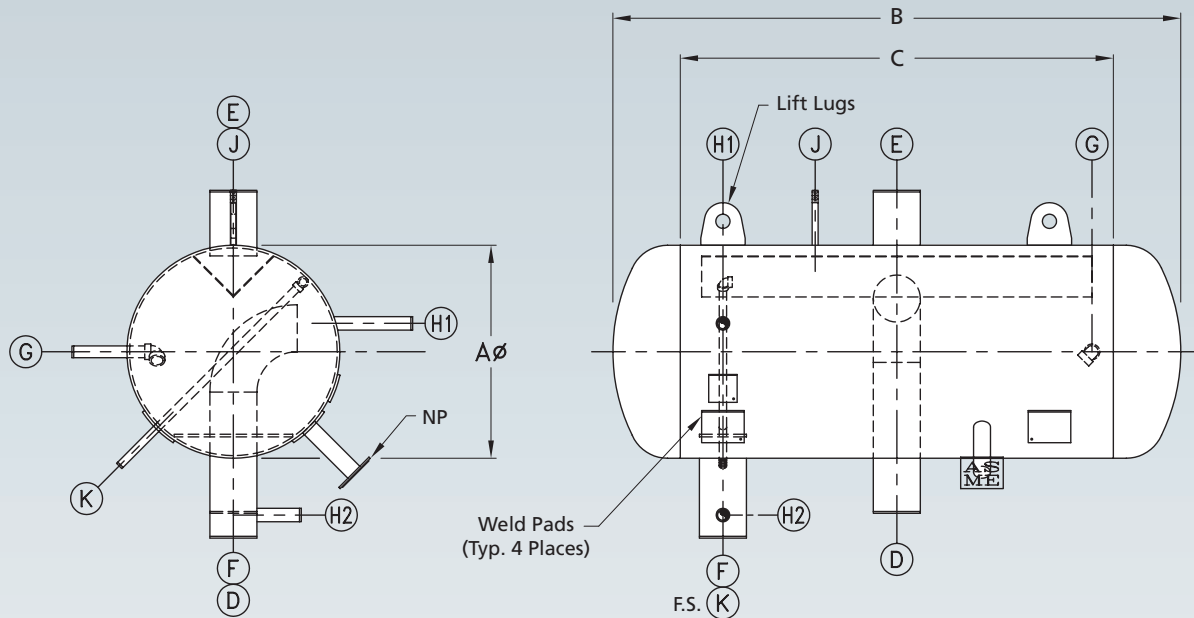

Model No.	A Diameter	B Overall Length	C Shell Length	D Suction Inlet	E Gas Outlet	F Liquid Outlet	G Liquid Make-Up	H Level Column	J Relief	K Oil Pot Vent	(Ft ³) Surge Volume	(lbs.) Vessel Weight
MHSD20-96	20	96	81	4	4	4	1-1/4	1-1/2	1-1/2	3/4	7.9	850
MHSD24-96	24	96	79-1/2	5	5	4	1-1/4	1-1/2	1-1/2	3/4	11	1045
MHSD30-96	30	96	77	6	6	6	1-1/2	1-1/2	1-1/2	3/4	18	1,350
MHSD36-96	36	96	74	6	6	6	2	1-1/2	1-1/2	3/4	26	1,575
MHSD42-96	42	96	71	8	8	6	2	1-1/2	1-1/2	3/4	36	1,890
MHSD48-120	48	120	92	10	8	8	2	1-1/2	1-1/2	3/4	59	2,700
MHSD54-144	54	144	113	10	8	8	2-1/2	1-1/2	1-1/2	3/4	90	4,500
MHSD60-144	60	144	110	10	10	10	3	1-1/2	1-1/2	3/4	110	5,000

Notes: All dimensions are given in inches.
Surge volume calculated between 4" OPL and HLCO 2" above center line.
Consult factory for certified drawings.

Split Flow Horizontal Surge Drum Capacity—Tons of Refrigeration R-717

Model No.	Evaporator Temperature °F									
	Single Stage*						Two Stage*			
	30°F	20°F	10°F	0°F	-10°F	-20°F	-20°F	-30°F	-40°F	-50°F
MHSD20-96	73	66	59	53	46	40	47	40	34	28
MHSD24-96	113	103	92	82	71	62	73	62	53	44
MHSD30-96	189	172	154	137	120	104	122	104	88	74
MHSD36-96	284	259	233	206	181	156	184	157	133	111
MHSD42-96	399	363	327	290	254	219	258	221	187	156
MHSD48-120	533	486	436	387	339	293	345	295	250	209
MHSD54-144	680	619	556	493	432	374	440	376	318	267
MHSD60-144	852	775	697	618	541	468	551	472	399	334

* Single stage capacities based on +96°F liquid supply temperature.
** Two stage capacities based on +25°F liquid supply temperature.

Horizontal Oil Pot 300# DWP

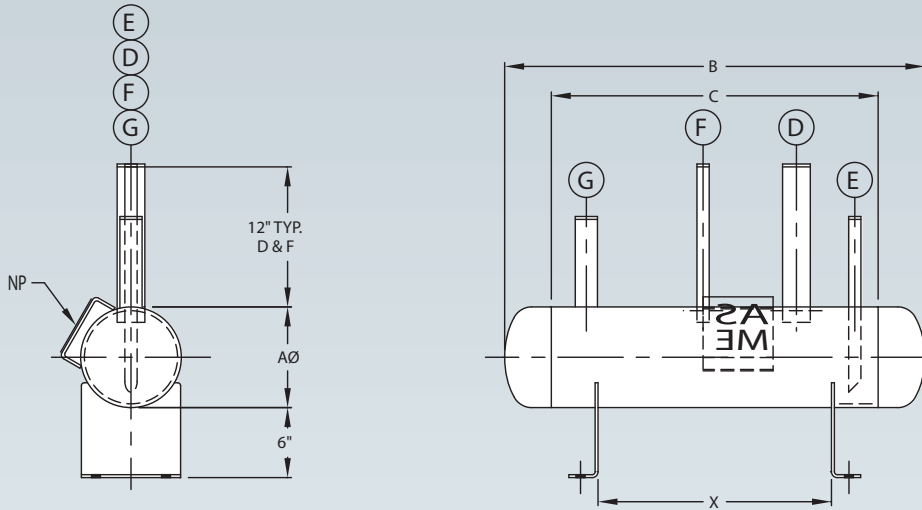

Model No.	A Diameter	B Overall Length	C Shell Length	D Oil Inlet	E Oil Outlet	F Vent	G Relief	X Supports	(Ft ³) Surge Volume	(lbs.) Vessel Weight
HOP8-36	8	36	28	2	3/4	3/4	1-1/2	20	0.77	141
HOP10-36	10	36	26	2	3/4	3/4	1-1/2	20	1.19	180

Notes: All dimensions are given in inches.
Consult factory for certified drawings.

RVS Std. Liquid Level Indicator Columns

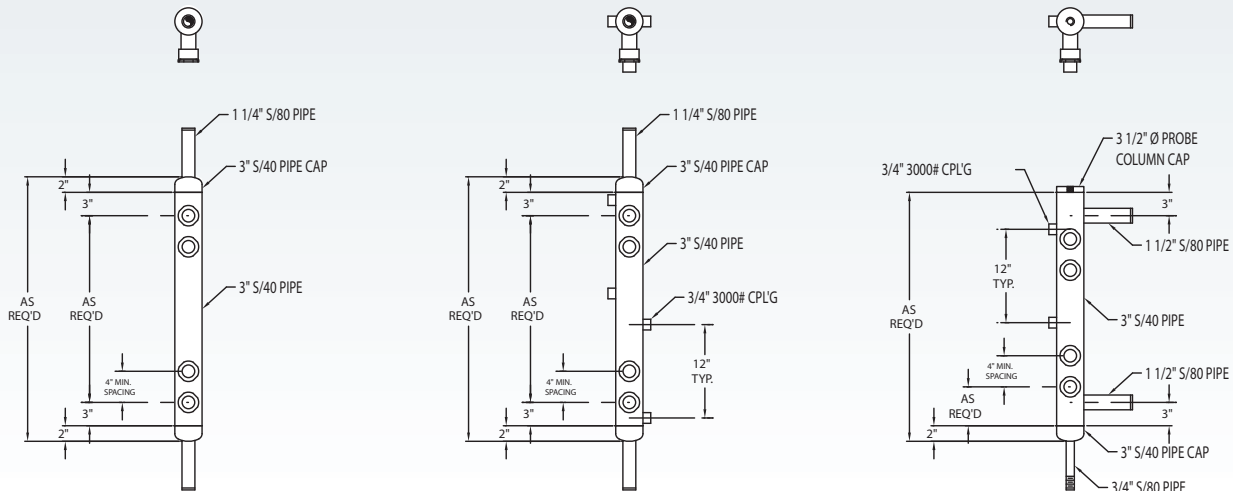

RVS is now offering a Refrigerant Level Switch/Indicator as an alternative to the glass level indicators. For additional information on Refrigerant Level Switch/Indicators please contact your local Representative or RVS directly at (979) 778-0095 or sales@rvscorp.com.

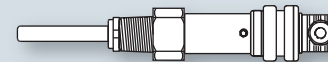



Design Your Own Vertical Vessel

_____ # DWP

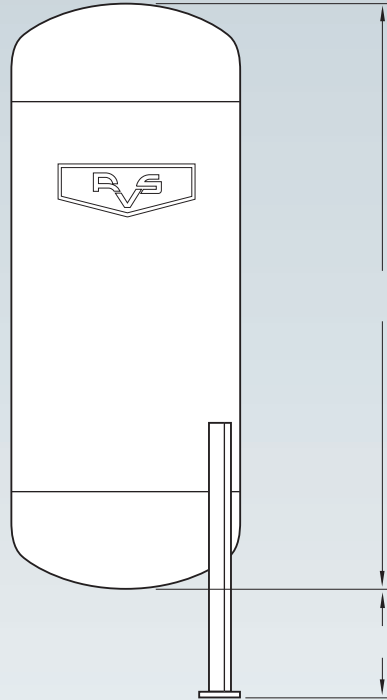
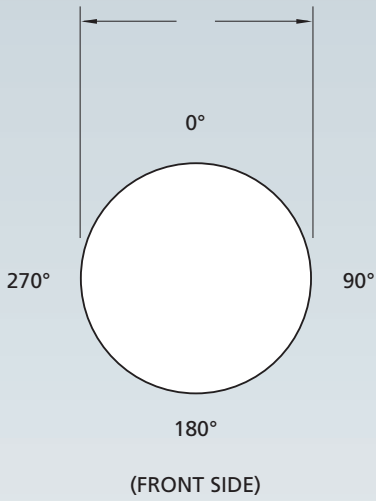

Nozzle	Description	Size	Type

Type of Vessel _____
 Capacity _____ Temperature _____ Refrigerant _____

Design Your Own Horizontal Vessel _____ # DWP

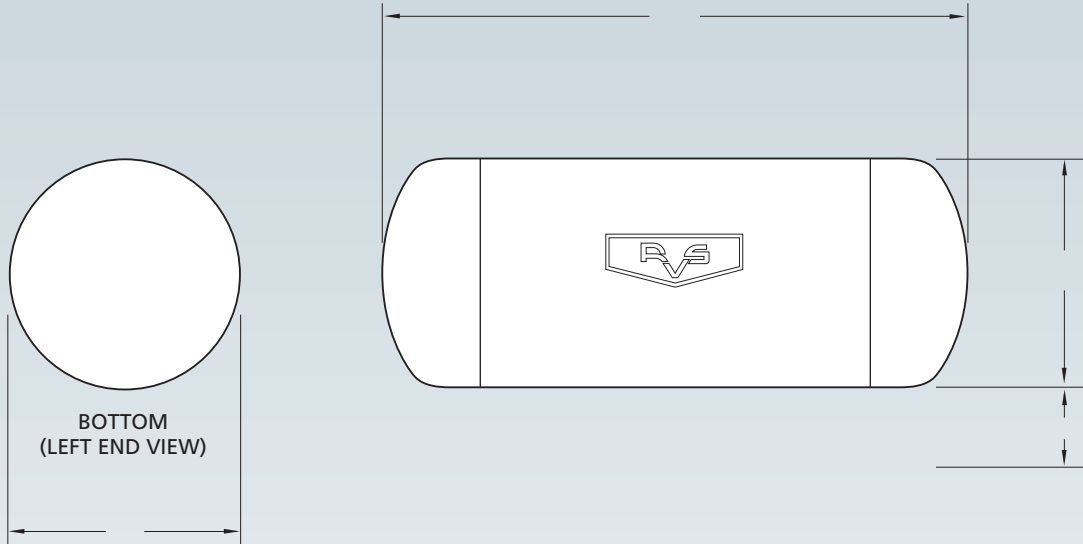

Nozzle	Description	Size	Type

Type of Vessel _____

Capacity _____ Temperature _____ Refrigerant _____

Refrigeration Valves & Systems Corporation

A wholly owned subsidiary of EVAPCO, Inc.

1520 Crosswind Dr. ■ Bryan, TX 77808 USA

PHONE: 979-778-0095 ■ FAX: 979-778-0030 ■ E-MAIL: sales@rvscorp.com

www.rvscorp.com

OTHER RVS PRODUCTS



MRP-V Recirculator

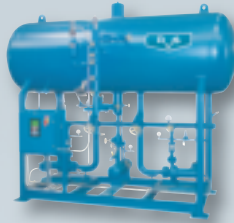

MRP-H Recirculator



MVI Intercooler

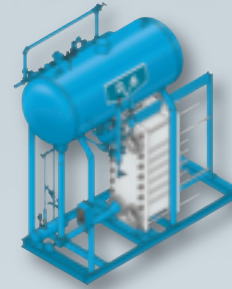

MPC Plate Chiller Package

EVAPCO QUALITY REFRIGERATION SYSTEM COMPONENTS

Evaporative Condensers



ATC-E/eco-ATC-A



cATC



ATC-DC



PHC



eco-PMC/PMC-E



LSC-E/LRC

Induced Draft Models

Forced Draft Models

Rooftop Air Units



Critical Process
Air Systems



Penthouse Evaporators



Make-Up Air Systems

Evaporators



Unit Coolers



Workroom Units



Low Profile Coolers

EVAPCO, Inc. — World Headquarters & Research/Development Center

EVAPCO, Inc. • P.O. Box 1300 • Westminster, MD 21158 USA

PHONE: 410-756-2600 • FAX: 410-756-6450 • E-MAIL: marketing@evapco.com

EVAPCO North America

EVAPCO, Inc.
World Headquarters
P.O. Box 1300
Westminster, MD 21158 USA
Phone: 410-756-2600
Fax: 410-756-6450
E-mail: marketing@evapco.com

EVAPCO South America

EVAPCO BRASIL
Equipamentos Industriais Ltda.
Rua Alexandre Dumas, 1601 - Conj. 13,
14, 15 - Edifício Stelvio Mazza
04717-004 Sao Paulo, Brazil
Phone: (55) 19-5681-2000

EVAPCO Europe

EVAPCO Europe BVBA
European Headquarters
Heersterveldweg 19
Industrieterrein Oost
B-3700 Tongeren,
Belgium
Phone: (32) 12-395029
Fax: (32) 12-238527
E-mail: evapco.europe@evapco.be

EVAPCO Asia/Pacific

EVAPCO Asia/Pacific Headquarters
1159 Luoning Rd., Baoshan Industrial Zone
Shanghai, P.R. China, Postal Code: 200949
Phone: (86) 21-6687-7786
Fax: (86) 21-6687-7008
E-mail: marketing@evapcochina.com

EVAPCO...SPECIALISTS IN HEAT TRANSFER PRODUCTS AND SERVICES.