

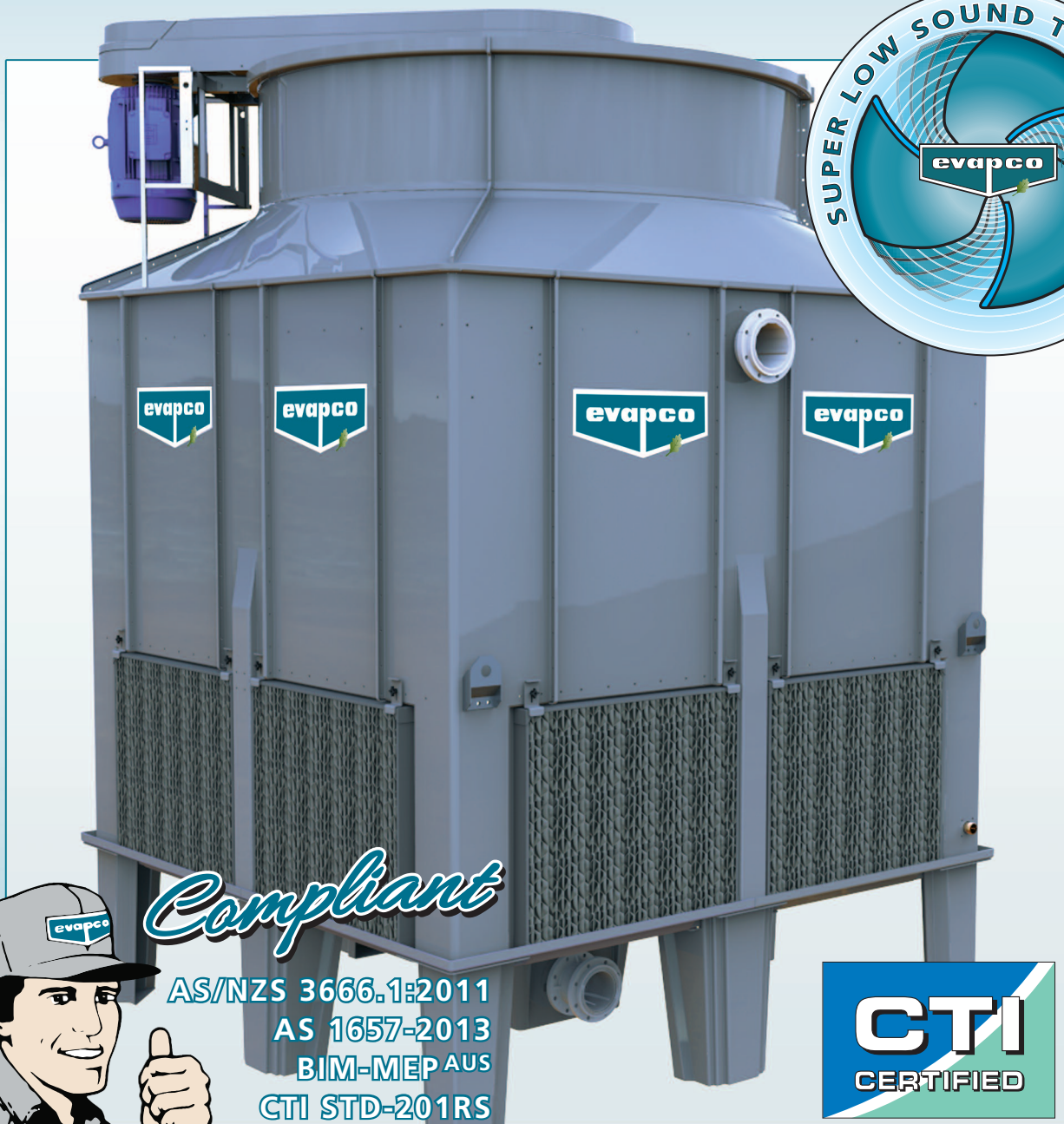

for LIFE

MTT

COOLING TOWER



Compliant

- AS/NZS 3666.1:2011
- AS 1657-2013
- BIM-MEP AUS
- CTI STD-201RS
- CTI ATC-128



CLOSED MOULDED FRP TECHNOLOGY
INDUCED DRAFT, COUNTERFLOW COOLING TOWER

Low Sound, Low Energy, Low Risk

† Mark owned by the Cooling Technology Institute



Since its founding in 1976, EVAPCO Incorporated has become an industry leader in the engineering and manufacturing of quality heat transfer products around the world. EVAPCO's mission is to provide first class service and quality products for the following markets:

- Commercial HVAC
- District Energy
- Industrial Process
- Industrial Refrigeration
- Power

EVAPCO's powerful combination of financial strength and technical expertise has established the company as a recognised manufacturer of market-leading products on a worldwide basis. EVAPCO is also recognised for the superior technology of its environmentally friendly product innovations in sound reduction and water management.

EVAPCO is an employee owned company with a strong emphasis on research & development and modern manufacturing plants. EVAPCO has earned a reputation for technological innovation and superior product quality by featuring products that are designed to offer these operating advantages:

- Higher System Efficiency
- Environmentally Friendly
- Lower Annual Operating Costs
- Reliable, Simple Operation and Maintenance

With an ongoing commitment to Research & Development programs, EVAPCO provides the most advanced products in the industry.

EVAPCO products have been marketed in Australia for more than 25 years beginning in the mid 1980's under an exclusive manufacturing agreement with F. Muller and continuing with the appointment of Aqua-Cool Towers as EVAPCO's exclusive licensee in 1995. In October 2009 EVAPCO, Inc acquired the controlling interest in Aqua-Cool Towers. The organisation was quickly restructured and all activities re-established under the new company name EVAPCO Australia, Pty Ltd.



EVAPCO, Inc. continues its dedication to making advancements in cooling tower technology. The **MTT** Cooling Tower is an industry first offering total corrosion resistance with precision moulded LRTM fibreglass (FRP) panels. The **MTT** combines EVAPCO's signature features of easy maintenance, efficient operation, low algae risk and low sound with total corrosion resistance. These features make the **MTT** the best cooling tower choice in the industry for projects that demand the highest level of corrosion resistance coupled with proven reliability.

ULTIMATE Corrosion Protection

- Heavy duty, closed moulded composite fibreglass basin, casing panels, and fan cylinders.
 - Non-corrosive PVC water distribution, drift eliminators and air inlet louvers.
 - Type 316 stainless steel wetted components.
 - Heavy duty hot dip galvanised steel mechanical equipment supports and dry components.
- (Optional Type 316 Stainless Steel available)



Fan Motors and Drive Assembly

- Standard MEPS or high efficiency MEPS compliant motors.
- Full access to motor from outside.
- 5 Year Motor and Drive Warranty.

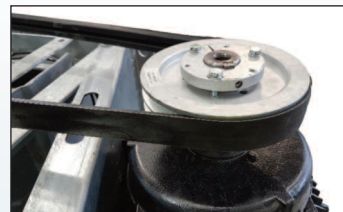

Heavy Duty Belt Drive System

- Standard heavy-duty flange mount bearings with a minimum L-10 life of 75,000 hours.
- External motor/belt adjustment.
- Solid-Back Multi-Groove Banded Belts and Totally Enclosed motors are standard.
- 5 Year Motor and Drive Warranty provided as standard.

WST Air Inlet Louvers (Water and Sight Tight)

- Easily removable for convenient access.
- Light-weight, non-corrosive 316 stainless steel louver frames.
- Zero splash-out.
- Proprietary design eliminates sunlight from entering tower, preventing biological growth.
- Compliant with AS/NZS 3666.1:2011 Clause 4.6 "Sunlight"

U.S. Patent No. 7,927,196





CTI Certified-Standard 201

- Independent 3rd party certification of thermal ratings.
- Reduces risk on end users by requiring manufacturers to physically test their cooling towers against published thermal ratings every year in order to achieve and maintain CTI certification.
- Ensures proper system efficiency.
- Eliminates necessity for costly field performance tests.

Precision Moulded LRTM Panels

- Smooth internal and external surfaces to prevent dirt and biological build up.
- Panels engineered for strength and structural stability with minimum internal steel framework.

Water Distribution System

- Non-corrosive PVC construction with EvapJet™ nozzles.
- Large orifice nozzles prevent clogging.
- Each nozzle produces large uniform spray pattern for a reduction of nozzles resulting in 66% fewer nozzles.
- Nozzles are capable of at least 50% turndown flow rate as standard.
- System branches have threaded end caps to assist with debris removal.

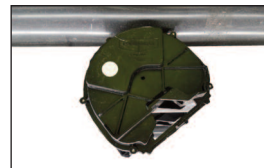

EvapJet™ Nozzle

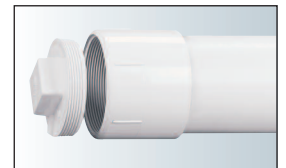

High Efficiency Drift Eliminators

- Industry-leading drift rate of less than 0.001%
- Compliant with AS/NZS 3666.1:2011 Clause 4.4 "Drift Control"
U.S Patent 6,315,804



EVAPAK® Fill

- Induces highly turbulent mixing of the air and water for superior heat transfer.
- Special drainage tips allow high water loading without excessive pressure drop.
- Flame spread rating of 5 per ASTM E84-81a.

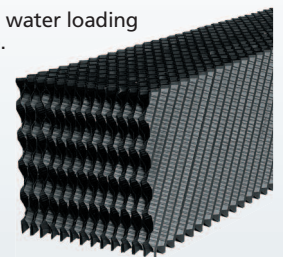

Easy Clean Sloped Basin

- Designed to completely drain the cold water basin.
- Helps prevent build-up of sediment and biological film.
- Eliminates standing water after drain down.
- Reduced water volume.

Optional Low Sound Solutions

- Super Low Sound Fans
- Low Sound Fans
- Water Silencers



Quick Connect Piping System

- Flanged inlet and outlet connections.
- Easy pipe connection at site for quick installation.



Super Low Sound Fan

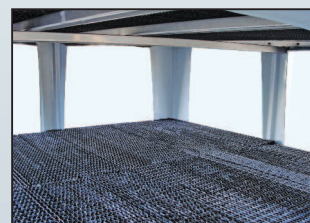

Water Silencers

The MTT Design

EVAPCO focuses on continuous improvement and is committed to developing the most innovative products in the industry. In keeping with this commitment, EVAPCO's MTT is the first cooling tower in the industry to feature composite fibreglass panels formed entirely by an advanced, environmentally friendly, LRTM closed mould manufacturing process.

The MTT is the result of a collaborative effort and the combined resources of EVAPCO's global entities. The concept and design basis of the MTT stems from EVAPCO Australia's proven MSS product line, having 20 years of installed history.

Beginning with the MSS concept, EVAPCO Inc. then further developed the MTT in 3D solid modelling software, then performed standardisation, strength analysis and generated CTI certified thermal performance at EVAPCO's premier Research and Development Headquarters in Maryland, USA.

EVAPCO Composites Sdn Bhd, in Malaysia then brought the design to life taking responsibility for mould design, pattern making, tooling and finally all FRP parts production utilising LRTM manufacturing process.

The MTT is unique in the industry having 3D solid modelling software designed patterns, moulds machined by 5-axis CNC, and with parts manufactured using LRTM. All aspects of the MTT, from concept to design to manufacture are performed "in-house" and by EVAPCO.

The final assembly of fabricated and globally sourced components is completed at one of EVAPCO's facilities. The final assembled products are available from Australia, Belgium, Italy or South Africa.

Light RTM Closed Moulding

The LRTM process is an advanced moulding technique utilising a "male" and a "female" mould to create a part. By using two mould surfaces, the resulting parts are high quality with perfectly smooth finishes on both sides.

In the first step of the parts production, a thin layer of gel coat is applied to both mould surfaces. EVAPCO's utilises high quality ISO Polyester, UV inhibited, color-match gel coat for superior finish, scratch resistance and UV protection. Next, a reinforcement glass fabric is placed into the female mould cavity. The male mould is aligned over and then lowered to form-fit the female mould. A full vacuum is then applied to the perimeter locking channel which locks the mould set together.

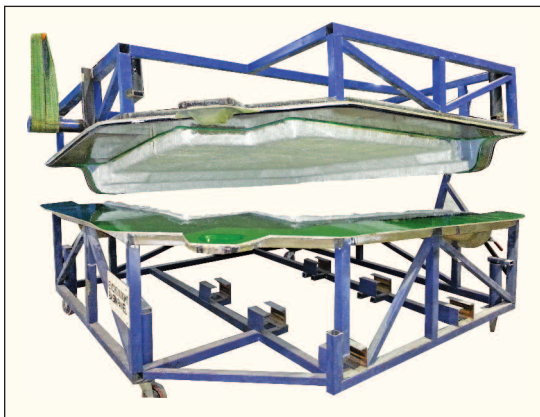

Reinforcement glass fabric loaded into mould cavity

A separate low vacuum is then applied to the part area of the mould cavity. A predetermined volume of resin is then injected in a controlled manner by a resin pump; the flow of the resin is aided by the partial vacuum. The resin infuses uniformly through the reinforcement glass fabric towards the center of part where the resin outlet and catch pot are located. The catch pot allows any excess of resin to be collected and prevents resin from entering the vacuum system. The infusion is deemed complete when the resin has fully and visibly displaced all air from the mould cavity.

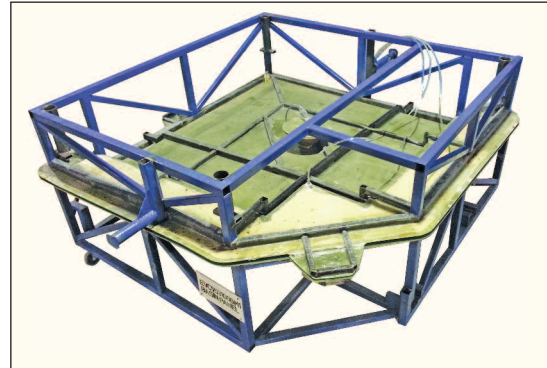

Closed Mould Manufacturing

Once the resin has fully infused, the resin pump is paused and resin flow to the mould is halted. Shortly thereafter the resin proceeds to cure via exothermic reaction; the part is left in the mould for up to 2 hours while it cools and hardens.

Once the part has sufficiently cured, the vacuum is released and the top mould is removed. The part is removed from the mould and then sent for CNC trimming and drilling process. Finally the part is wiped down and prepared for shipment.

While seemingly simple in theory, LRTM requires a commitment of resources and an initial capital investment that is beyond the comfort level of most cooling tower companies. When successfully implemented, the LRTM process provides many benefits including superior quality, 300-400% increased productivity compared to open mould and less VOC emission leading to a cleaner and more comfortable working environment.

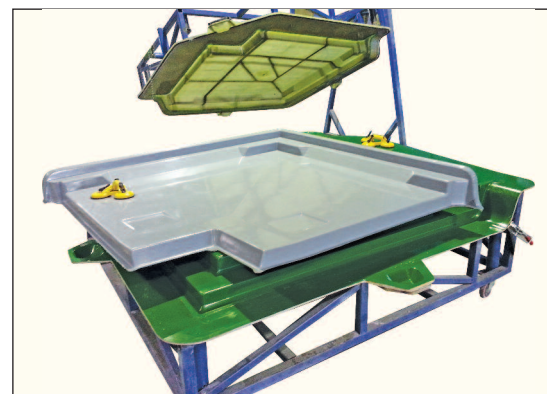

Completed part; removed from mould

DESIGN FEATURES

MTT

Advantages of LRTM

LRTM is widely used in the advanced industries of aerospace, automotive and marine because it produces precision parts, with higher quality and improved surface finish in less time, and with less styrene emission.

Solid Laminate Construction

All panels of the MTT Cooling Tower are structural by design, thus reducing the need for a matrix of internal stainless steel bracing and framework. Designed and constructed for superior strength, the MTT panels are formed using LRTM, having consistent physical and mechanical properties.

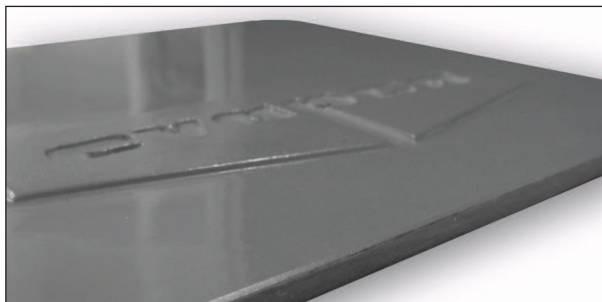

LRTM panel having uniform part thickness

Tolerance and Parts Repeatability

Consistent high quality parts are the desirable advantage of the LRTM process. With LRTM, part thickness is uniform which ensures part strength and dimensional accuracy. Being able to produce consistent, quality parts is imperative to the final overall quality of the MTT. With quality and precision in the design and manufacture, the MTT has an unprecedented high degree of "fit-n-finish."

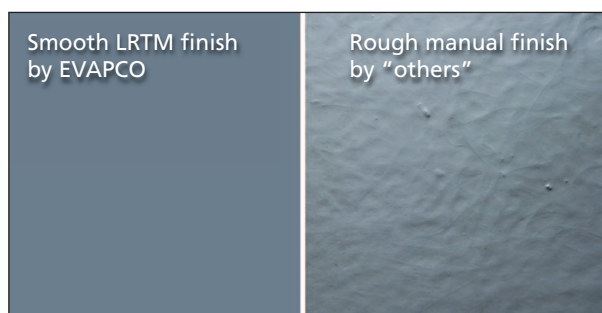

Two Sides Perfectly Smooth

LRTM produces aesthetically and physically superior panels having a smooth and shiny finish on both sides. The picture shows the superior finish of LRTM as compared to the rough surface otherwise produced by conventional labour intensive open mould FRP processes.

Reduced Styrene Emissions

The closed nature of LRTM moulding provides reduced VOC emissions and a more worker-friendly environment than open mould processes. Simply put, closed mould manufacturing results in a cleaner, safer, and more productive production plant.

Complex Shapes

LRTM provides superior design flexibility for the creation of complex shapes, forms and compound curves. The fibreglass parts used on the MTT have been designed with this curvature complexity providing inherent part strength.

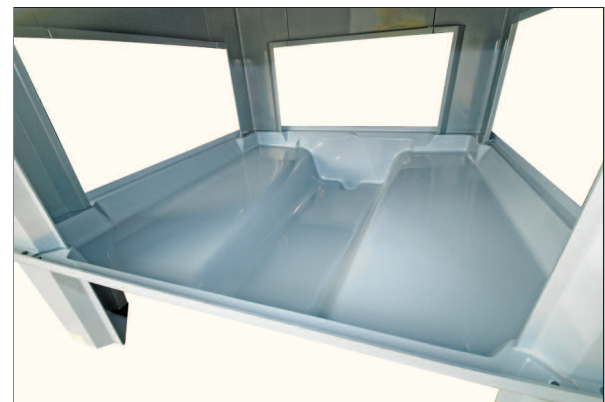

Compound curvature provides inherent part strength

Laboratory Tested for Strength and Consistency

All panel thicknesses have undergone destructive testing for determining the mechanical properties of the LRTM laminates. All tests have been performed in accordance with European (EU) and American (ASTM) Standards, to measure flexural properties, compressive and tensile strengths, modulus and glass content.

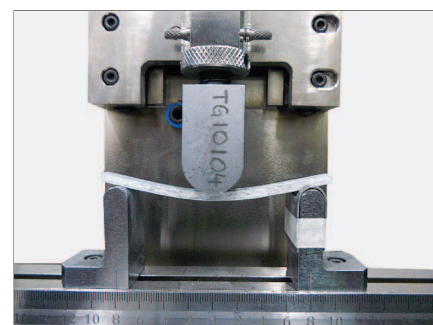

The testing results provided a confirmation of theoretical properties of the LRTM manufactured panels.

MTT

DESIGN FEATURES

Principle of Operation

Warm water from the heat source is pumped to the water distribution system at the top of the tower. The water is distributed over the wet deck fill by means of large orifice nozzles. Simultaneously, air is drawn in through the air inlet louvers at the base of the tower and travels upward through the wet deck fill opposite the water flow.

A small portion of the water is evaporated which removes the heat from the remaining water. The warm moist air is drawn to the top of the cooling tower by the fan and discharged to the atmosphere. The cooled water drains to the basin at the bottom of the tower and is returned to the heat source.

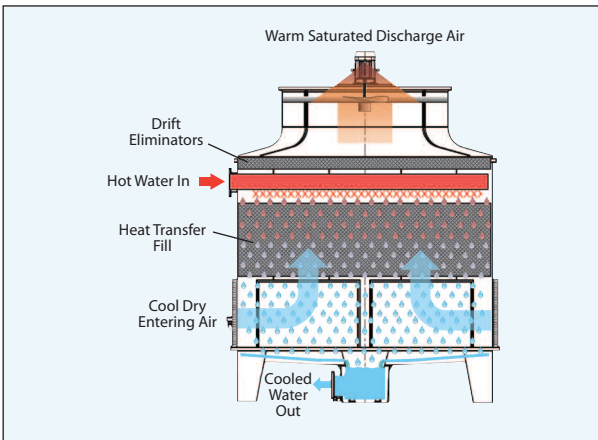

Anti-Clogging and Low Turndown Water Distribution System

The water distribution system is constructed of PVC pipe and EvapJet™ ABS plastic water diffusers for corrosion protection in this key area. The piping is easily removable for cleaning. The wide orifice nozzles mounted on the side of the pipe used in the MTT water distribution system help prevent clogging, reducing the maintenance costs of the water distribution system.

The EvapJet™ nozzles are capable of at least 50% turndown flow rate as standard. The versatile nature of this nozzle gives the end user the best opportunity to reduce pump energy during periods of low heat load.

The spray pressure for all MTT Cooling Towers is between 7 and 41 kPa at the inlet header.

The actual spray pressure will be shown on the submittal which is prepared for each unit.



High Efficiency Drift Eliminators

The MTT is provided with an efficient drift eliminator system that effectively reduces entrained water droplets from the air discharge to less than 0.001% of the recirculated water flow rate. EVAPCO's drift eliminators are twice as efficient as the requirement set out in AS 3666 Clause 4.4 Drift Control.

The drift eliminators are constructed of inert polyvinyl chloride (PVC), effectively eliminating corrosion of these vital components.



WST Air Inlet Louvers (Water and Sight Tight)

EVAPCO'S WST Air Inlet Louvers keep water in and sunlight out of induced draft products. The unique nonplanar design is made from light-weight framed PVC sections which have no loose hardware, enabling easy unit access.

The louver's air channels are optimised to maintain fluid dynamic and thermodynamic efficiency and block all line-of-sight paths into the basin eliminating splash-out; even when the fans are off. Additionally, algae growth is minimised by blocking all sunlight into the basin, making the louvers compliant with AS 3666 Clause 4.6 Sunlight.

The combination of easy access, no splash-out and minimised algae growth saves the end user money on maintenance hours, water consumption and water treatment costs.

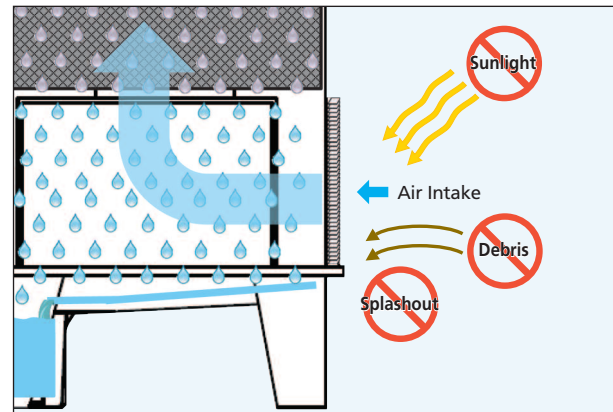

DESIGN FEATURES

MTT

EVAPAK® Fill

EVAPCO's fill in the MTT Cooling Tower range is designed to induce highly turbulent mixing of the air and water for superior heat transfer. Special drainage tips allow high water loadings without excessive pressure drop.

The fill is constructed of inert polyvinyl chloride (PVC), will not rot or decay, and is formulated to withstand water temperatures of up to 55°C. The fill is also constructed in easy to handle and removable block form. For design conditions with dirty water or higher temperatures, special fill types are available. Consult your EVAPCO representative for further details.

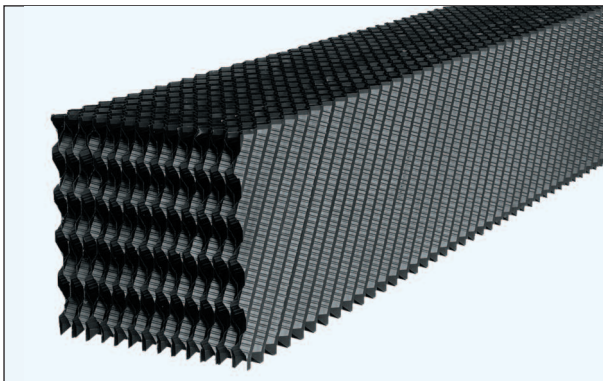

High Temperature Solutions

EVAPCO's standard fill and drift eliminators can withstand temperatures up to 55°C. For higher temperature applications, EVAPCO can provide hard polyvinyl chloride (HPVC) which is rated for temperatures up to 65°C. For high temperature applications, the standard PVC water distribution system is upgraded to chlorinated polyvinyl chloride (CPVC).

Stainless Steel Strainers

Strainers are subjected to harsh conditions through the life cycle of the tower. The stainless steel strainer is provided by EVAPCO as standard to ensure longevity of the tower pumping system, limiting large dirt or debris from entering.



Low Sound Solutions

Water Silencers – Reduces Water Noise in the Cold Water Basin up to 7 dB(A)!

EVAPCO's water silencers are located in the cold water basin. The water silencers reduce the high frequency noise associated with the falling water and is capable of reducing overall sound levels **4dB(A) to 7dB(A)** measured at 1.5m from the side or end of the unit. The water silencers reduce overall sound level **9dB(A) to 12 dB(A)** (depending on water loading and louver height) measured 1.5m from the side or end of the unit when water is circulated with fans off.

The Water Silencers are constructed of lightweight PVC sections and can be easily removed for access to the basin area. This option has no impact on unit thermal performance.

Note: Water Silencers are not available on 4' wide models and models with "No Basin".

Super Low Sound Fan 9 – 15 dB(A) Reduction!

The Super Low Sound Fan offered by EVAPCO utilises an extremely wide chord blade design available for sound sensitive applications where the lowest sound levels are desired. The fan is two-piece molded heavy duty FRP construction utilising a forward swept blade design.

The Super Low Sound Fan is capable of reducing the unit sound pressure levels **9dB(A) to 15dB(A)**, depending on specific unit selection and measurement location compared to the standard MTT. The Super Low Sound Fan will have no impact on unit thermal performance.

Note: Available on 8', 10' and 12' wide models only.



*The Low Energy of an Axial Fan with
The Low Sound of a Centrifugal Fan*

Low Sound Fan 4 – 7 dB(A) Reduction!

The Low Sound Fan offered by EVAPCO is a wide chord blade design for sound sensitive application where low sound levels are desired.

The Low Sound Fan shall utilise a unique soft-connect blade-to-hub design that is compatible with Variable Speed Drives. Since the blades are not rigidly connected to the fan hub, no vertical vibration forces are transmitted to the unit structure which reduces sound pressure levels **4 dB(A) to 7 dB(A)**, depending on specific unit selection and measurement location.

The fans are high efficiency axial propeller type and are CTI Certified on the MTT product line.



Banded Belt Drive System Design

The MTT uses the standard belt drive system utilised in EVAPCO's induced draft counterflow cooling towers. The EVAPCO Banded Belt Drive system is engineered for heavy-duty cooling tower operation and provides trouble-free operation in the most severe of cooling tower applications. The Banded Belt Drive System is applicable to 2.4m wide box sizes and larger.

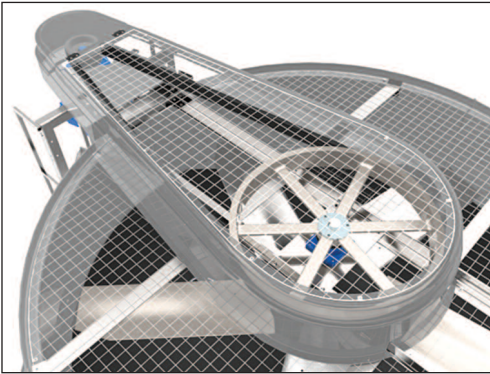

Drive configuration for 8x, 10x, 11x, and 12x units.
(Belt guard shown as transparent for clarity)

The fan motor and drive assembly are mounted externally to the unit in a belt drive configuration. Belt tension is checked and adjusted by tightening the J-bolts on the motor base or moving the motor along the threaded rod. The lubrication lines are extended to the motor base, making bearing lubrication easy. All motors and lubrication lines are safely accessible with the (optional) ladder-platform.

Most box sizes utilise under slung and shaft up TEFC motors, outside the discharge air stream. Box sizes 16 ft and wider utilise TEAO motors which are installed atop of the tower and in the discharge air stream.

Fan Motors

All units utilise MEPS 2006 standard efficiency motors. Motors are epoxy coated as standard, unless otherwise requested.

Banded Belt Drive

The Banded Belt Drive is a solid-back multi-groove belt system that has high lateral rigidity. The belt is designed for cooling tower service, and is constructed of neoprene with polyester chords. The drive belt is sized for 150% of the motor nameplate power ensuring long and trouble free operation.

Drive System Pulleys

Drive system pulleys located within the discharge airstream of the cooling tower are constructed of an aluminium alloy.

Fan Shaft Bearings

The fan shaft bearings on the MTT are specially selected to provide long life, minimising costly downtime. They are rated for a minimum L-10 life of 75,000 hours, making them the heaviest duty flange mount bearing in the industry used for cooling towers.

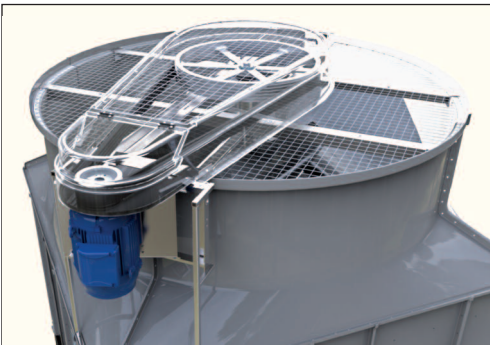

Drive configuration for 8x, 10x, 11x, and 12x units.
(Belt guard shown as transparent for clarity)

4' Wide Models Only

The fan motor is mounted internally, in a direct drive configuration. Access to the drive system for maintenance is via the access panel and ladder and platforms are not required. The TEAO fan motor is epoxy coated as standard.



4x6 and 4x9 units.



ENGINEERING DATA AND DIMENSIONS

MTT

Box Sizes: 4x6 and 4x9

CONNECTION DESCRIPTION	CONNECTION (QTY) SIZE IN MM
	MTT 14-2F6 TO 14-3F9
SYSTEM FLUID IN (INLET)	(1) 100
SYSTEM FLUID OUT (OUTLET)	(1) 100
MAKE-UP (MU)	(1) 25
OVERFLOW (OF)	(1) 50
DRAIN (D)	(1) 50

MTT 14-2F6 TO 14-3G6

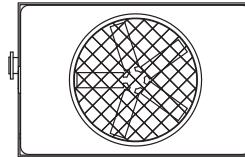

MTT 14-2E9 TO 14-3F9

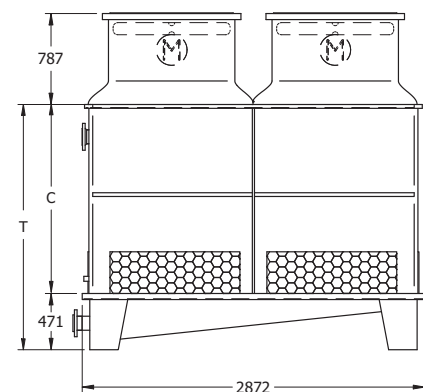
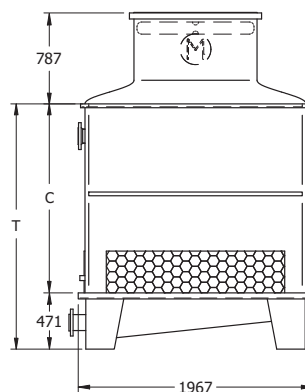
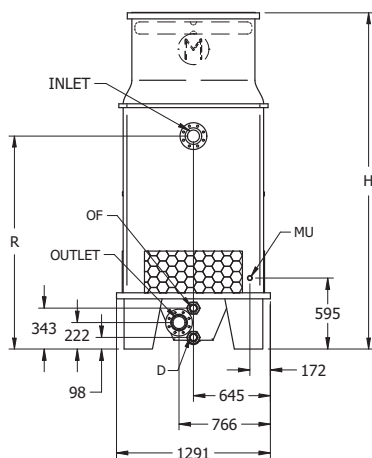
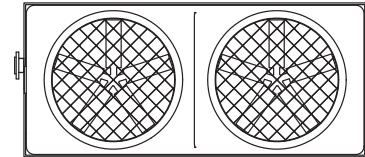

Table 1 Engineering Data

Model No.	Fan		Weights (Kg)				Operating Basin Volume (L)	Dimensions (mm)			
	Fan Motor (kW)	Air Flow (m³/s)	Shipping	Shipping Heaviest Section*	Rigging Heaviest Section	Operating		H	T	C	R
MTT 14-2F6	2.2	7.5	560	560	465	840	175	2819	2056	1585	1787
MTT 14-2G6	4	8.8	565	565	465	845	175	2819	2056	1585	1787
MTT 14-3F6	2.2	7.4	605	605	505	880	175	3124	2361	1890	2092
MTT 14-3G6	4	8.7	610	610	510	885	175	3124	2361	1890	2092
MTT 14-2E9	(2) 1.5	10.3	815	815	685	1245	254	2819	2056	1585	1787
MTT 14-2F9	(2) 2.2	11.7	840	840	710	1265	254	2819	2056	1585	1787
MTT 14-3E9	(2) 1.5	10.2	880	880	750	1305	254	3124	2361	1890	2092
MTT 14-3F9	(2) 2.2	11.5	905	905	770	1330	254	3124	2361	1890	2092

- NOTE: (1) Do not use catalogue drawings for pre-fabrication. Dimensions and weights are subject to change.
 (2) Adequate spacing must be allowed for unobstructed airflow and access to the unit. Refer to the MT Layout Guidelines section of this brochure.
 (3) An adequately sized bleed line must be installed in the cooling tower system to prevent build-up of impurities in the recirculated water.
 (4) Contact your local EVAPCO sales representative for thermal selection and pricing.

* Ships as one piece. Contact factory for alternate arrangements.

Box Size: 8x8

CONNECTION DESCRIPTION	CONNECTION (QTY) SIZE IN MM
	MTT 18-2G8 TO 18-4J8
SYSTEM FLUID IN (INLET)	(1) 200
SYSTEM FLUID OUT (OUTLET)	(1) 200
MAKE-UP (MU)	(1) 50
OVERFLOW (OF)	(1) 50
DRAIN (D)	(1) 50

MTT 18-2G8 TO 18-4J8

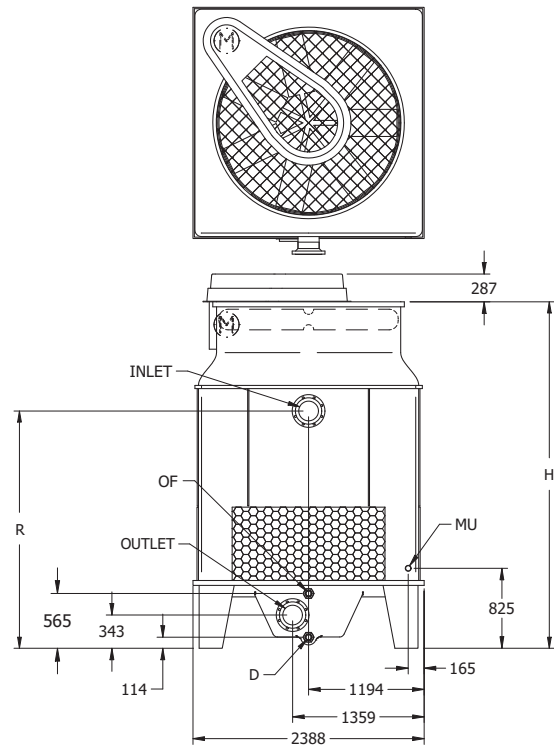
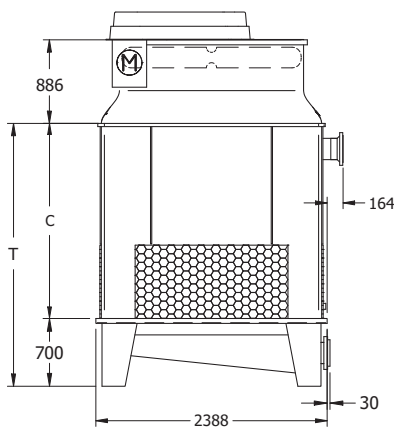

Table 2 Engineering Data

Model No.	Fan		Weights (Kg)				Operating Basin Volume (L)	Dimensions (mm)			
	Fan Motor (kW)	Air Flow (m³/s)	Shipping	Shipping Heaviest Section	Rigging Heaviest Section	Operating		H	T	C	R
MTT 18-2G8	4	14.3	1465	905	730	2230	594	3577	2714	2014	2426
MTT 18-2H8	5.5	16.3	1490	905	730	2255	594	3577	2714	2014	2426
MTT 18-2I8	7.5	17.9	1490	905	730	2260	594	3577	2714	2014	2426
MTT 18-3G8	4	14.1	1565	1005	830	2330	594	3881	3018	2318	2731
MTT 18-3H8	5.5	16.0	1590	1005	830	2355	594	3881	3018	2318	2731
MTT 18-3I8	7.5	17.6	1590	1005	830	2360	594	3881	3018	2318	2731
MTT 18-3J8	11	19.9	1645	1005	830	2415	594	3881	3018	2318	2731
MTT 18-4G8	4	13.8	1660	1100	925	2425	594	4186	3323	2623	3036
MTT 18-4H8	5.5	15.8	1685	1100	925	2450	594	4186	3323	2623	3036
MTT 18-4I8	7.5	17.3	1685	1100	925	2455	594	4186	3323	2623	3036
MTT 18-4J8	11	19.6	1740	1100	925	2510	594	4186	3323	2623	3036
SLSF ADDITION			+70			+70		+255			

- NOTE: (1) Do not use catalogue drawings for pre-fabrication. Dimensions and weights are subject to change.
 (2) Adequate spacing must be allowed for unobstructed airflow and access to the unit. Refer to the MT Layout Guidelines section of this brochure.
 (3) An adequately sized bleed line must be installed in the cooling tower system to prevent build-up of impurities in the recirculated water.
 (4) Contact your local EVAPCO sales representative for thermal selection and pricing.

ENGINEERING DATA AND DIMENSIONS



Box Size: 16x8

CONNECTION DESCRIPTION	CONNECTION (QTY) SIZE IN MM
	MTT 216-2G8 TO 216-4J8
SYSTEM FLUID IN (INLET)	(2) 200
SYSTEM FLUID OUT (OUTLET)	(2) 200
MAKE-UP (MU)	(2) 50
OVERFLOW (OF)	(2) 50
DRAIN (D)	(2) 50
EQUALIZER (E)	(2) 200

MTT 216-2G8 to 216-4J8

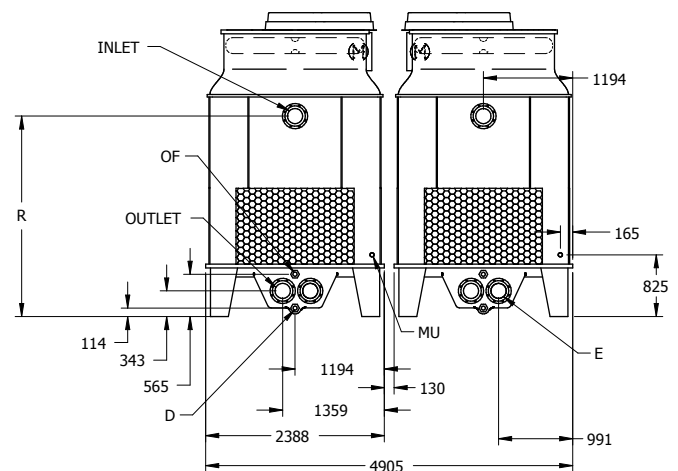
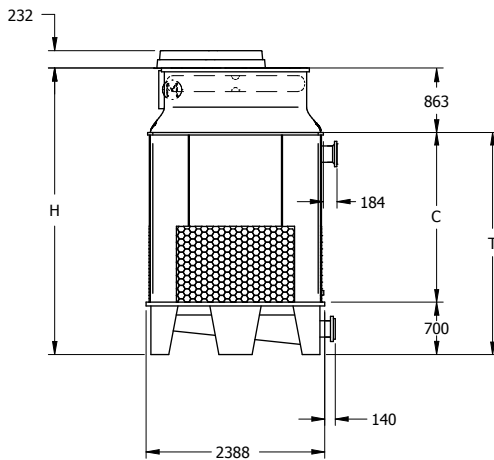
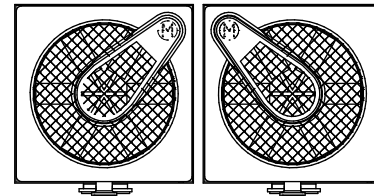

Table 3 Engineering Data

Model No.	Fan		Weights (Kg)				Operating Basin Volume (L)	Dimensions (mm)			
	Fan Motor (kW)	Air Flow (m³/s)	Shipping	Shipping Heaviest Section	Rigging Heaviest Section	Operating		H	T	C	R
MTT 216-2G8	(2) 4	28.5	3020	955	775	4555	1188	3831	2968	2268	2680
MTT 216-2H8	(2) 5.5	32.6	3065	955	775	4600	1188	3831	2968	2268	2680
MTT 216-2I8	(2) 7.5	35.7	3075	955	775	4610	1188	3831	2968	2268	2680
MTT 216-3G8	(2) 4	28.1	3210	1050	870	4745	1188	4136	3272	2572	2985
MTT 216-3H8	(2) 5.5	32.0	3255	1050	870	4790	1188	4136	3272	2572	2985
MTT 216-3I8	(2) 7.5	35.1	3265	1050	870	4800	1188	4136	3272	2572	2985
MTT 216-3J8	(2) 11	39.9	3375	1050	870	4910	1188	4136	3272	2572	2985
MTT 216-4G8	(2) 4	27.6	3400	1000	1200	4935	1188	4440	3577	2877	3290
MTT 216-4H8	(2) 5.5	31.5	3445	1000	1225	4980	1188	4440	3577	2877	3290
MTT 216-4I8	(2) 7.5	34.5	3455	1000	1230	4990	1188	4440	3577	2877	3290
MTT 216-4J8	(2) 11	39.2	3565	1000	1285	5100	1188	4440	3577	2877	3290
SLSF ADDITION			+140			+140		+255			

- NOTE: (1) Do not use catalogue drawings for pre-fabrication. Dimensions and weights are subject to change.
 (2) Adequate spacing must be allowed for unobstructed airflow and access to the unit. Refer to the MT Layout Guidelines section of this brochure.
 (3) An adequately sized bleed line must be installed in the cooling tower system to prevent build-up of impurities in the recirculated water.
 (4) Contact your local EVAPCO sales representative for thermal selection and pricing.

Box Size: 24x8

CONNECTION DESCRIPTION	CONNECTION (QTY) SIZE IN MM
	MTT 324-2G8 TO 324-4J8
SYSTEM FLUID IN (INLET)	(3) 200
SYSTEM FLUID OUT (OUTLET)	(3) 200
MAKE-UP (MU)	(3) 50
OVERFLOW (OF)	(3) 50
DRAIN (D)	(3) 50
EQUALIZER (E)	(3) 200

MTT 324-2G8 TO 324-4J8

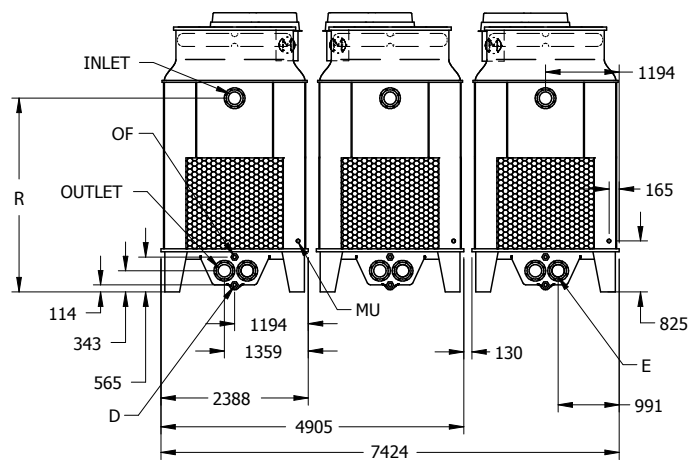
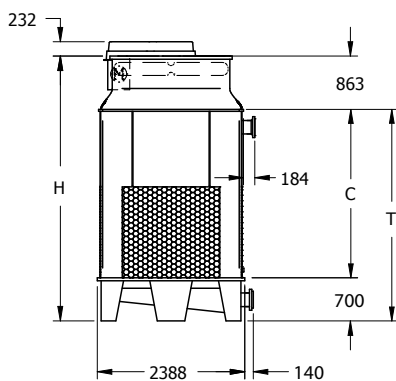
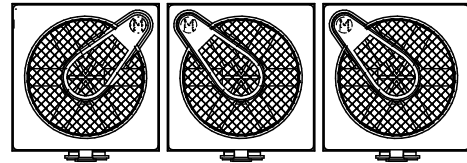

Table 4 Engineering Data

Model No.	Fan		Weights (Kg)				Operating Basin Volume (L)	Dimensions (mm)			
	Fan Motor (kW)	Air Flow (m³/s)	Shipping	Shipping Heaviest Section	Rigging Heaviest Section	Operating		H	T	C	R
MTT 324-2G8	(3) 4	42.8	4695	860	1065	6995	1782	4288	3425	2725	3137
MTT 324-2H8	(3) 5.5	48.9	4765	860	1090	7060	1782	4288	3425	2725	3137
MTT 324-2I8	(3) 7.5	53.6	4775	860	1095	7075	1782	4288	3425	2725	3137
MTT 324-3G8	(3) 4	42.2	4995	960	1165	7295	1782	4593	3730	3030	3442
MTT 324-3H8	(3) 5.5	48.0	5060	960	1190	7360	1782	4593	3730	3030	3442
MTT 324-3I8	(3) 7.5	52.7	5075	960	1195	7375	1782	4593	3730	3030	3442
MTT 324-3J8	(3) 11	59.8	5240	960	1245	7540	1782	4593	3730	3030	3442
MTT 324-4G8	(3) 4	41.5	5280	1055	1260	7580	1782	4898	4034	3334	3747
MTT 324-4H8	(3) 5.5	47.2	5350	1055	1285	7650	1782	4898	4034	3334	3747
MTT 324-4I8	(3) 7.5	51.8	5360	1055	1290	7660	1782	4898	4034	3334	3747
MTT 324-4J8	(3) 11	58.8	5525	1055	1345	7825	1782	4898	4034	3334	3747
SLSF ADDITION			+210			+210		+255			

- NOTE: (1) Do not use catalogue drawings for pre-fabrication. Dimensions and weights are subject to change.
 (2) Adequate spacing must be allowed for unobstructed airflow and access to the unit. Refer to the MT Layout Guidelines section of this brochure.
 (3) An adequately sized bleed line must be installed in the cooling tower system to prevent build-up of impurities in the recirculated water.
 (4) Contact your local EVAPCO sales representative for thermal selection and pricing.

ENGINEERING DATA AND DIMENSIONS

MTT

Box Size: 8x12

CONNECTION DESCRIPTION	CONNECTION (QTY) SIZE IN MM
	MTT 18-2H12 TO 18-4L12
SYSTEM FLUID IN (INLET)	(1) 200
SYSTEM FLUID OUT (OUTLET)	(1) 200
MAKE-UP (MU)	(1) 50
OVERFLOW (OF)	(1) 50
DRAIN (D)	(1) 50

MTT 18-2H12 TO 18-4L12

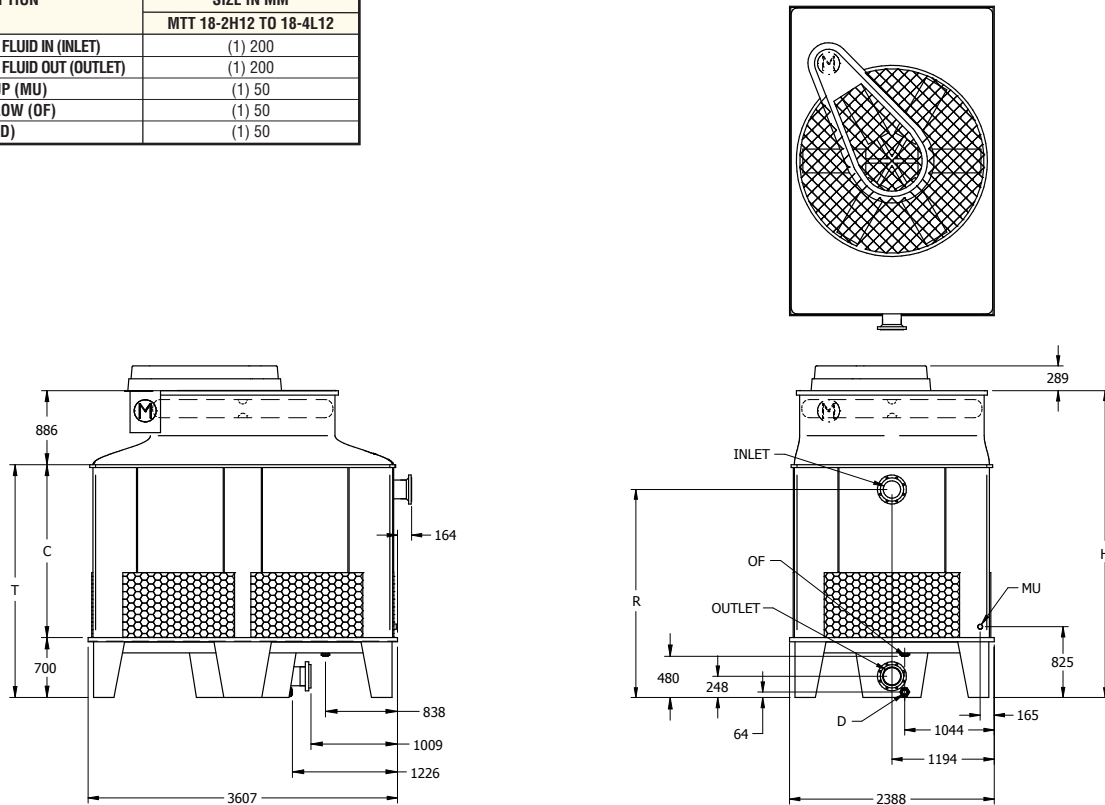

Table 5 Engineering Data

Model No.	Fan		Weights (Kg)				Operating Basin Volume (L)	Dimensions (mm)			
	Fan Motor (kW)	Air Flow (m ³ /s)	Shipping	Shipping Heaviest Section	Rigging Heaviest Section	Operating		H	T	C	R
MTT 18-2H12	5.5	22.5	2265	1395	1050	2955	1188	3577	2714	2014	2426
MTT 18-2I12	7.5	24.7	2270	1395	1050	2960	1188	3577	2714	2014	2426
MTT 18-2J12	11	28.1	2330	1395	1050	3020	1188	3577	2714	2014	2426
MTT 18-2K12	15	30.8	2360	1395	1050	3050	1188	3577	2714	2014	2426
MTT 18-3H12	5.5	22.2	2405	1540	1190	3095	1188	3881	3018	2318	2731
MTT 18-3I12	7.5	24.3	2415	1540	1190	3105	1188	3881	3018	2318	2731
MTT 18-3J12	11	27.6	2470	1540	1190	3160	1188	3881	3018	2318	2731
MTT 18-3K12	15	30.2	2500	1540	1190	3190	1188	3881	3018	2318	2731
MTT 18-3L12	18.5	32.4	2515	1540	1190	3200	1188	3881	3018	2318	2731
MTT 18-4H12	5.5	21.8	2545	1680	1330	3235	1188	4186	3323	2623	3036
MTT 18-4I12	7.5	23.9	2555	1680	1330	3245	1188	4186	3323	2623	3036
MTT 18-4J12	11	27.1	2615	1680	1330	3300	1188	4186	3323	2623	3036
MTT 18-4K12	15	29.7	2640	1680	1330	3330	1188	4186	3323	2623	3036
MTT 18-4L12	18.5	31.9	2655	1680	1330	3345	1188	4186	3323	2623	3036
SLSF ADDITION			+70			+70		+255			

- NOTE: (1) Do not use catalogue drawings for pre-fabrication. Dimensions and weights are subject to change.
 (2) Adequate spacing must be allowed for unobstructed airflow and access to the unit. Refer to the MT Layout Guidelines section of this brochure.
 (3) An adequately sized bleed line must be installed in the cooling tower system to prevent build-up of impurities in the recirculated water.
 (4) Contact your local EVAPCO sales representative for thermal selection and pricing.

Box Size: 16x12

CONNECTION DESCRIPTION	CONNECTION (QTY) SIZE IN MM
	MTT 216-2H12 TO 216-4L12
SYSTEM FLUID IN (INLET)	(2) 200
SYSTEM FLUID OUT (OUTLET)	(2) 200
MAKE-UP (MU)	(2) 50
OVERFLOW (OF)	(2) 50
DRAIN (D)	(2) 50
EQUALIZER (E)	(2) 200

MTT 216-2H12 TO 216-4L12

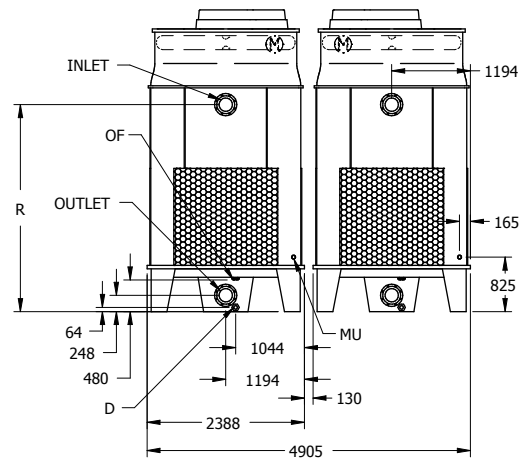
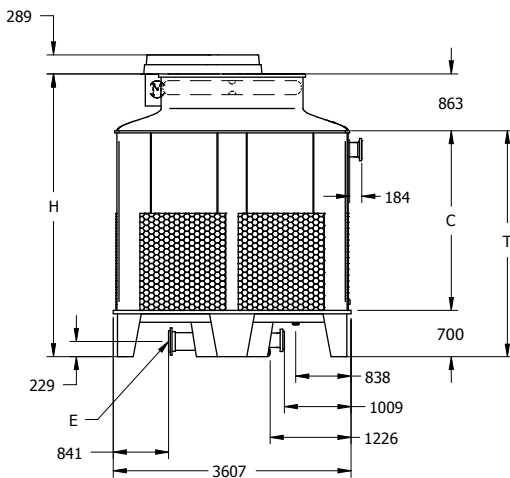
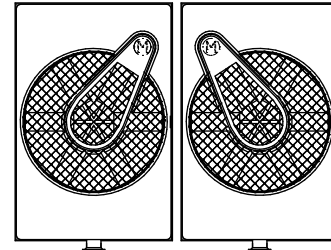

Table 6 Engineering Data

Model No.	Fan		Weights (Kg)				Operating Basin Volume (L)	Dimensions (mm)			
	Fan Motor (kW)	Air Flow (m³/s)	Shipping	Shipping Heaviest Section	Rigging Heaviest Section	Operating		H	T	C	R
MTT 216-2H12	(2) 5.5	45.1	4770	1310	1480	6150	2376	4288	3425	2725	3137
MTT 216-2I12	(2) 7.5	49.4	4790	1310	1490	6170	2376	4288	3425	2725	3137
MTT 216-2J12	(2) 11	56.2	4910	1310	1545	6285	2376	4288	3425	2725	3137
MTT 216-2K12	(2) 15	61.6	4960	1310	1575	6340	2376	4288	3425	2725	3137
MTT 216-3H12	(2) 5.5	44.4	5055	1450	1620	6430	2376	4593	3730	3030	3442
MTT 216-3I12	(2) 7.5	48.6	5070	1450	1630	6450	2376	4593	3730	3030	3442
MTT 216-3J12	(2) 11	55.2	5190	1450	1685	6570	2376	4593	3730	3030	3442
MTT 216-3K12	(2) 15	60.4	5245	1450	1715	6620	2376	4593	3730	3030	3442
MTT 216-3L12	(2) 18.5	64.8	5270	1450	1730	6650	2376	4593	3730	3030	3442
MTT 216-4H12	(2) 5.5	43.6	5335	1590	1760	6715	2376	4898	4034	3334	3747
MTT 216-4I12	(2) 7.5	47.7	5350	1590	1770	6730	2376	4898	4034	3334	3747
MTT 216-4J12	(2) 11	54.3	5470	1590	1830	6850	2376	4898	4034	3334	3747
MTT 216-4K12	(2) 15	59.4	5525	1590	1855	6905	2376	4898	4034	3334	3747
MTT 216-4L12	(2) 18.5	63.7	5550	1590	1870	6930	2376	4898	4034	3334	3747
SLSF ADDITION			+140			+140		+255			

- NOTE: (1) Do not use catalogue drawings for pre-fabrication. Dimensions and weights are subject to change.
 (2) Adequate spacing must be allowed for unobstructed airflow and access to the unit. Refer to the MT Layout Guidelines section of this brochure.
 (3) An adequately sized bleed line must be installed in the cooling tower system to prevent build-up of impurities in the recirculated water.
 (4) Contact your local EVAPCO sales representative for thermal selection and pricing.

ENGINEERING DATA AND DIMENSIONS



Box Size: 24x12

CONNECTION DESCRIPTION	CONNECTION (QTY) SIZE IN MM
	MTT 324-2H12 TO 324-4L12
SYSTEM FLUID IN (INLET)	(3) 200
SYSTEM FLUID OUT (OUTLET)	(3) 200
MAKE-UP (MU)	(3) 50
OVERFLOW (OF)	(3) 50
DRAIN (D)	(3) 50
EQUALIZER (E)	(3) 200

MTT 324-2H12 TO 324-4L12

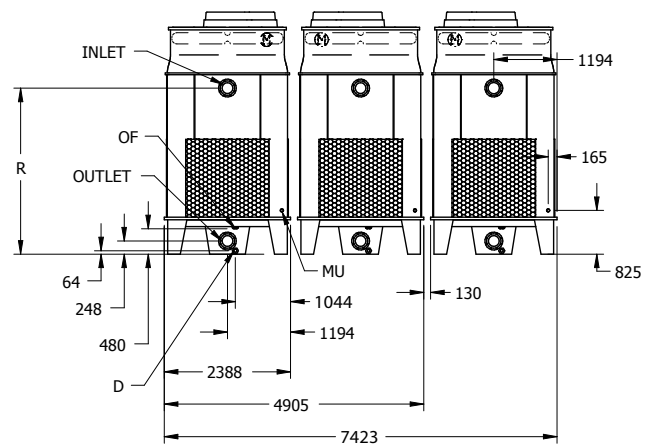
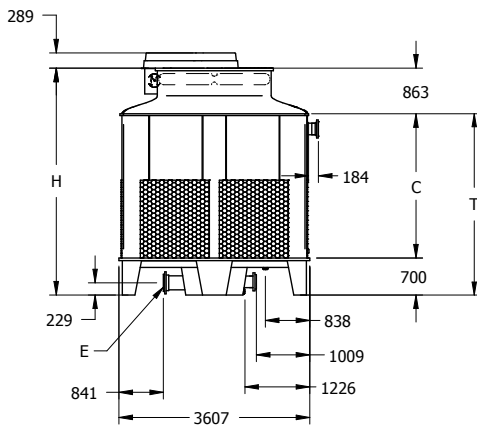
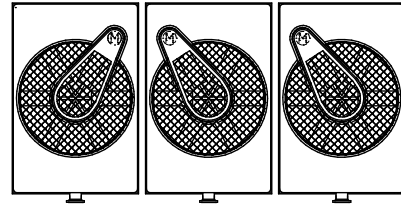

Table 7 Engineering Data

Model No.	Fan		Weights (Kg)				Operating Basin Volume (L)	Dimensions (mm)			
	Fan Motor (kW)	Air Flow (m³/s)	Shipping	Shipping Heaviest Section	Rigging Heaviest Section	Operating		H	T	C	R
MTT 324-2H12	(3) 5.5	67.7	7160	1310	1480	9225	3564	4288	3425	2725	3137
MTT 324-2I12	(3) 7.5	74.2	7185	1310	1490	9255	3564	4288	3425	2725	3137
MTT 324-2J12	(3) 11	84.4	7360	1310	1545	9430	3564	4288	3425	2725	3137
MTT 324-2K12	(3) 15	92.5	7445	1310	1575	9510	3564	4288	3425	2725	3137
MTT 324-3H12	(3) 5.5	66.7	7580	1450	1620	9650	3564	4593	3730	3030	3442
MTT 324-3I12	(3) 7.5	73	7605	1450	1630	9675	3564	4593	3730	3030	3442
MTT 324-3J12	(3) 11	83	7785	1450	1685	9850	3564	4593	3730	3030	3442
MTT 324-3K12	(3) 15	90.8	7865	1450	1715	9935	3564	4593	3730	3030	3442
MTT 324-3L12	(3) 18.5	97.4	7905	1450	1730	9975	3564	4593	3730	3030	3442
MTT 324-4H12	(3) 5.5	65.4	8000	1590	1760	10070	3564	4898	4034	3334	3747
MTT 324-4I12	(3) 7.5	71.7	8030	1590	1770	10095	3564	4898	4034	3334	3747
MTT 324-4J12	(3) 11	81.5	8205	1590	1830	10275	3564	4898	4034	3334	3747
MTT 324-4K12	(3) 15	89.3	8285	1590	1855	10355	3564	4898	4034	3334	3747
MTT 324-4L12	(3) 18.5	95.8	8330	1590	1870	10395	3564	4898	4034	3334	3747
SLSF ADDITION			+210			+210		+255			

- NOTE: (1) Do not use catalogue drawings for pre-fabrication. Dimensions and weights are subject to change.
 (2) Adequate spacing must be allowed for unobstructed airflow and access to the unit. Refer to the MT Layout Guidelines section of this brochure.
 (3) An adequately sized bleed line must be installed in the cooling tower system to prevent build-up of impurities in the recirculated water.
 (4) Contact your local EVAPCO sales representative for thermal selection and pricing.

Box Size: 8x24

CONNECTION DESCRIPTION	CONNECTION (QTY) SIZE IN MM
	MTT 28-2H24 TO 28-4L24
SYSTEM FLUID IN (INLET)	(2) 200
SYSTEM FLUID OUT (OUTLET)	(2) 200
MAKE-UP (MU)	(2) 50
OVERFLOW (OF)	(2) 50
DRAIN (D)	(2) 50
EQUALIZER (E)	(2) 250

MTT 28-2H24 TO 28-2L24

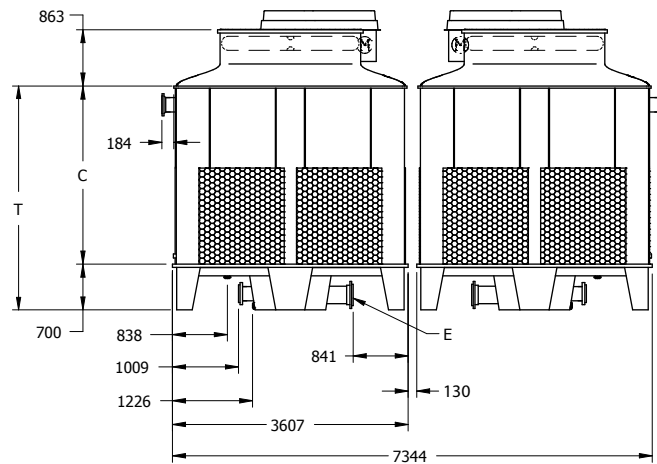
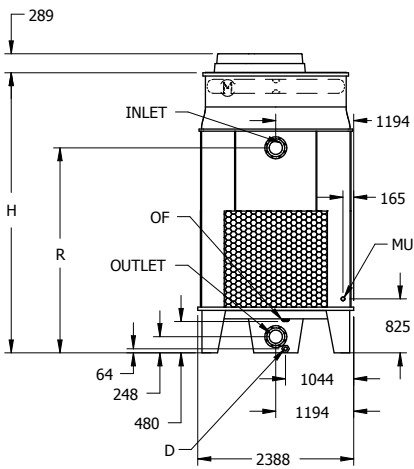
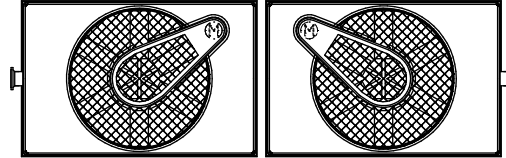

Table 8 Engineering Data

Model No.	Fan		Weights (Kg)				Operating Basin Volume (L)	Dimensions (mm)			
	Fan Motor (kW)	Air Flow (m³/s)	Shipping	Shipping Heaviest Section	Rigging Heaviest Section	Operating		H	T	C	R
MTT 28-2H24	(2) 5.5	45.1	4770	1310	1480	6150	2376	4288	3425	2725	3137
MTT 28-2I24	(2) 7.5	49.4	4790	1310	1490	6170	2376	4288	3425	2725	3137
MTT 28-2J24	(2) 11	56.2	4910	1310	1545	6285	2376	4288	3425	2725	3137
MTT 28-2K24	(2) 15	61.6	4960	1310	1575	6340	2376	4288	3425	2725	3137
MTT 28-3H24	(2) 5.5	44.4	5055	1450	1620	6430	2376	4593	3730	3030	3442
MTT 28-3I24	(2) 7.5	48.6	5070	1450	1630	6450	2376	4593	3730	3030	3442
MTT 28-3J24	(2) 11	55.2	5190	1450	1685	6570	2376	4593	3730	3030	3442
MTT 28-3K24	(2) 15	60.4	5245	1450	1715	6620	2376	4593	3730	3030	3442
MTT 28-3L24	(2) 18.5	64.8	5270	1450	1730	6650	2376	4593	3730	3030	3442
MTT 28-4H24	(2) 5.5	43.6	5335	1590	1760	6715	2376	4898	4034	3334	3747
MTT 28-4I24	(2) 7.5	47.7	5350	1590	1770	6730	2376	4898	4034	3334	3747
MTT 28-4J24	(2) 11	54.3	5470	1590	1830	6850	2376	4898	4034	3334	3747
MTT 28-4K24	(2) 15	59.4	5525	1590	1855	6905	2376	4898	4034	3334	3747
MTT 28-4L24	(2) 18.5	63.7	5550	1590	1870	6930	2376	4898	4034	3334	3747
SLSF ADDITION			+140			+140		+255			

- NOTE: (1) Do not use catalogue drawings for pre-fabrication. Dimensions and weights are subject to change.
 (2) Adequate spacing must be allowed for unobstructed airflow and access to the unit. Refer to the MT Layout Guidelines section of this brochure.
 (3) An adequately sized bleed line must be installed in the cooling tower system to prevent build-up of impurities in the recirculated water.
 (4) Contact your local EVAPCO sales representative for thermal selection and pricing.

ENGINEERING DATA AND DIMENSIONS



Box Size: 10x10

CONNECTION DESCRIPTION	CONNECTION (QTY) SIZE IN MM
	MTT 110-2G10 TO 110-4K10
SYSTEM FLUID IN (INLET)	(1) 200
SYSTEM FLUID OUT (OUTLET)	(1) 200
MAKE-UP (MU)	(1) 50
OVERFLOW (OF)	(1) 50
DRAIN (D)	(1) 50

MTT 110-2G10 TO 110-4K10

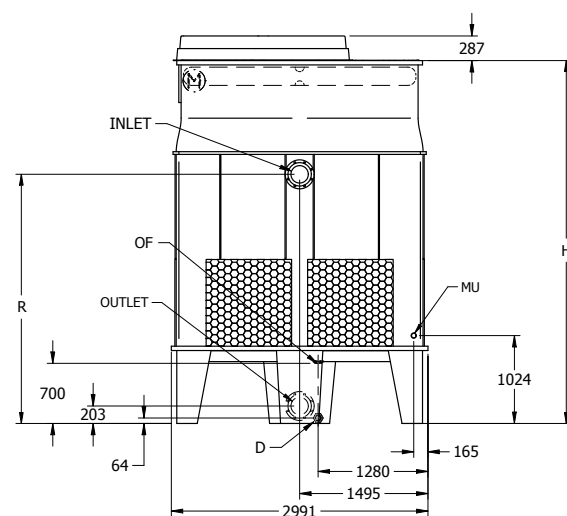
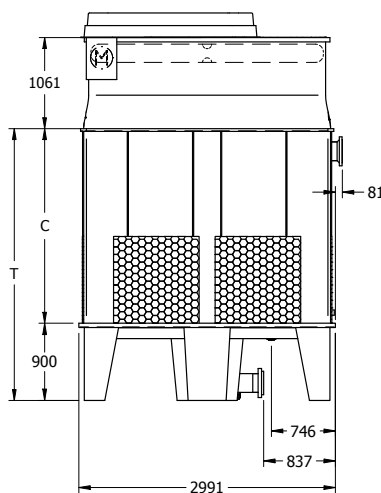
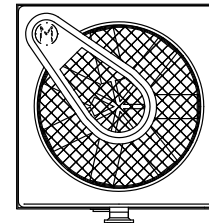

Table 9 Engineering Data

Model No.	Fan		Weights (Kg)				Operating Basin Volume (L)	Dimensions (mm)			
	Fan Motor (kW)	Air Flow (m³/s)	Shipping	Shipping Heaviest Section	Rigging Heaviest Section	Operating		H	T	C	R
MTT 110-2G10	4	21.3	2120	1330	1075	3030	552	4229	3168	2268	2880
MTT 110-2H10	5.5	24.2	2140	1330	1075	3055	552	4229	3168	2268	2880
MTT 110-2I10	7.5	26.6	2150	1330	1075	3060	552	4229	3168	2268	2880
MTT 110-2J10	11	30.2	2210	1330	1075	3120	552	4229	3168	2268	2880
MTT 110-3G10	4	20.9	2265	1245	1530	3175	552	4534	3472	2572	3185
MTT 110-3H10	5.5	23.9	2285	1245	1550	3200	552	4534	3472	2572	3185
MTT 110-3I10	7.5	26.1	2295	1245	1560	3205	552	4534	3472	2572	3185
MTT 110-3J10	11	29.7	2355	1245	1620	3265	552	4534	3472	2572	3185
MTT 110-3K10	15	32.4	2370	1245	1635	3285	552	4534	3472	2572	3185
MTT 110-4G10	4	20.6	2405	1390	1670	3315	552	4839	3777	2877	3490
MTT 110-4H10	5.5	23.4	2425	1390	1690	3340	552	4839	3777	2877	3490
MTT 110-4I10	7.5	25.7	2435	1390	1700	3350	552	4839	3777	2877	3490
MTT 110-4J10	11	29.2	2495	1390	1760	3405	552	4839	3777	2877	3490
MTT 110-4K10	15	31.9	2515	1390	1780	3425	552	4839	3777	2877	3490
SLSF ADDITION			+320			+320		+330			

- NOTE: (1) Do not use catalogue drawings for pre-fabrication. Dimensions and weights are subject to change.
 (2) Adequate spacing must be allowed for unobstructed airflow and access to the unit. Refer to the MT Layout Guidelines section of this brochure.
 (3) An adequately sized bleed line must be installed in the cooling tower system to prevent build-up of impurities in the recirculated water.
 (4) Contact your local EVAPCO sales representative for thermal selection and pricing.

Box Size: 10x20

CONNECTION DESCRIPTION	CONNECTION (QTY) SIZE IN MM
	MTT 210-2G20 TO 210-4K20
SYSTEM FLUID IN (INLET)	(2) 200
SYSTEM FLUID OUT (OUTLET)	(2) 200
MAKE-UP (MU)	(2) 50
OVERFLOW (OF)	(2) 50
DRAIN (D)	(2) 50
EQUALIZER (E)	(2) 250

MTT 210-2G20 TO 210-4K20

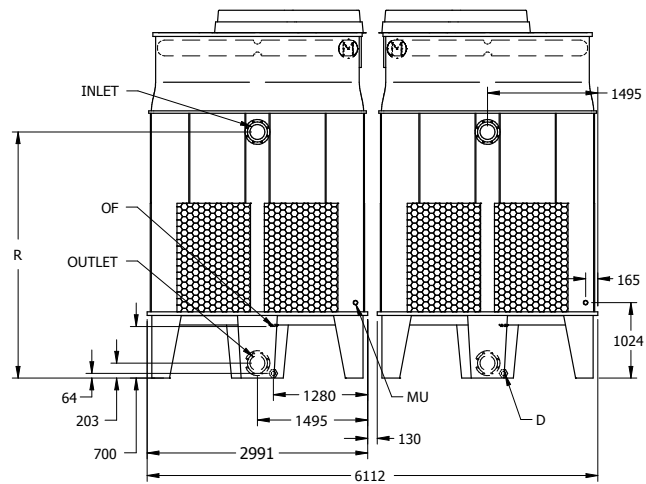
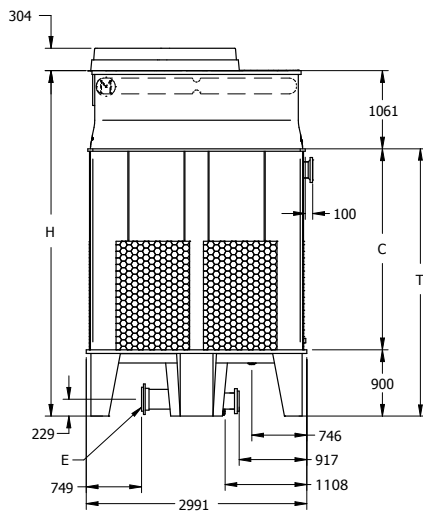
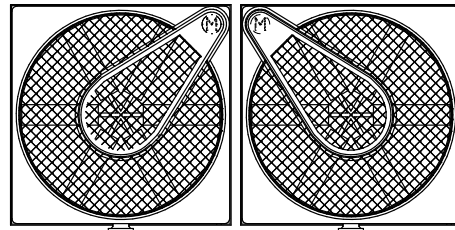

Table 10 Engineering Data

Model No.	Fan		Weights (Kg)				Operating Basin Volume (L)	Dimensions (mm)			
	Fan Motor (kW)	Air Flow (m³/s)	Shipping	Shipping Heaviest Section	Rigging Heaviest Section	Operating		H	T	C	R
MTT 210-2G20	(2) 4	42.6	4545	1250	1535	6370	1104	4686	3626	2726	3337
MTT 210-2H20	(2) 5.5	48.5	4590	1250	1555	6415	1104	4686	3626	2726	3337
MTT 210-2I20	(2) 7.5	53.1	4610	1250	1565	6430	1104	4686	3626	2726	3337
MTT 210-2J20	(2) 11	60.4	4725	1250	1625	6550	1104	4686	3626	2726	3337
MTT 210-3G20	(2) 4	41.9	4825	1395	1675	6650	1104	4991	3930	3030	3642
MTT 210-3H20	(2) 5.5	47.7	4870	1395	1695	6695	1104	4991	3930	3030	3642
MTT 210-3I20	(2) 7.5	52.3	4890	1395	1705	6715	1104	4991	3930	3030	3642
MTT 210-3J20	(2) 11	59.3	5010	1395	1765	6830	1104	4991	3930	3030	3642
MTT 210-3K20	(2) 15	64.9	5045	1395	1785	6865	1104	4991	3930	3030	3642
MTT 210-4G20	(2) 4	41.2	5115	1540	1820	6940	1104	5296	4235	3335	3947
MTT 210-4H20	(2) 5.5	46.9	5160	1540	1840	6985	1104	5296	4235	3335	3947
MTT 210-4I20	(2) 7.5	51.4	5180	1540	1850	7005	1104	5296	4235	3335	3947
MTT 210-4J20	(2) 11	58.3	5300	1540	1910	7120	1104	5296	4235	3335	3947
MTT 210-4K20	(2) 15	63.9	5335	1540	1930	7160	1104	5296	4235	3335	3947
SLSF ADDITION			+640			+640		+330			

- NOTE: (1) Do not use catalogue drawings for pre-fabrication. Dimensions and weights are subject to change.
 (2) Adequate spacing must be allowed for unobstructed airflow and access to the unit. Refer to the MT Layout Guidelines section of this brochure.
 (3) An adequately sized bleed line must be installed in the cooling tower system to prevent build-up of impurities in the recirculated water.
 (4) Contact your local EVAPCO sales representative for thermal selection and pricing.

ENGINEERING DATA AND DIMENSIONS

MTT

Box Size: 10x30

CONNECTION DESCRIPTION	CONNECTION (QTY) SIZE IN MM
	MTT 310-2G30 TO 310-4K30
SYSTEM FLUID IN (INLET)	(3) 200
SYSTEM FLUID OUT (OUTLET)	(3) 200
MAKE-UP (MU)	(3) 50
OVERFLOW (OF)	(3) 50
DRAIN (D)	(3) 50
EQUALIZER (E)	(3) 250

MTT 310-2G30 to 310-4K30

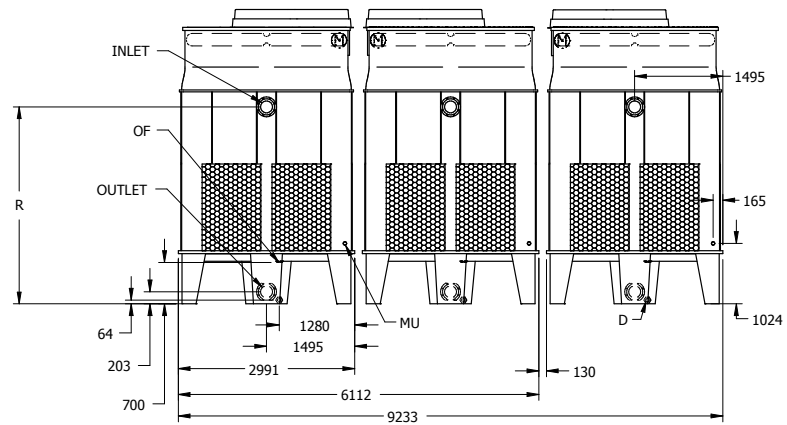
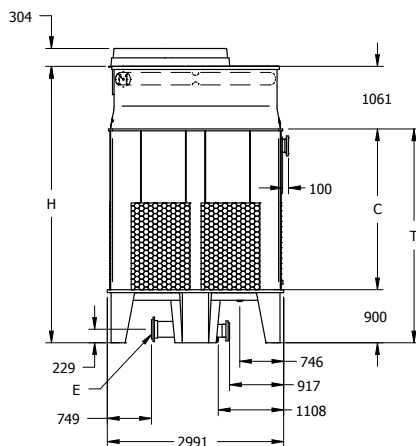
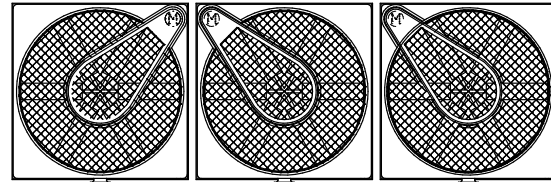

Table 11 Engineering Data

Model No.	Fan		Weights (Kg)				Operating Basin Volume (L)	Dimensions (mm)			
	Fan Motor (kW)	Air Flow (m³/s)	Shipping	Shipping Heaviest Section	Rigging Heaviest Section	Operating		H	T	C	R
MTT 310-2G30	(3) 4	63.9	6815	1250	1535	9555	1656	4686	3626	2726	3337
MTT 310-2H30	(3) 5.5	72.7	6885	1250	1555	9620	1656	4686	3626	2726	3337
MTT 310-2I30	(3) 7.5	79.7	6915	1250	1565	9650	1656	4686	3626	2726	3337
MTT 310-2J30	(3) 11	90.6	7090	1250	1625	9825	1656	4686	3626	2726	3337
MTT 310-3G30	(3) 4	62.8	7240	1395	1675	9975	1656	4991	3930	3030	3642
MTT 310-3H30	(3) 5.5	71.6	7305	1395	1695	10045	1656	4991	3930	3030	3642
MTT 310-3I30	(3) 7.5	78.4	7335	1395	1705	10070	1656	4991	3930	3030	3642
MTT 310-3J30	(3) 11	89	7510	1395	1765	10245	1656	4991	3930	3030	3642
MTT 310-3K30	(3) 15	97.4	7565	1395	1785	10300	1656	4991	3930	3030	3642
MTT 310-4G30	(3) 4	61.8	7675	1540	1820	10410	1656	5296	4235	3335	3947
MTT 310-4H30	(3) 5.5	70.4	7745	1540	1840	10480	1656	5296	4235	3335	3947
MTT 310-4I30	(3) 7.5	77.1	7770	1540	1850	10505	1656	5296	4235	3335	3947
MTT 310-4J30	(3) 11	87.6	7945	1540	1910	10680	1656	5296	4235	3335	3947
MTT 310-4K30	(3) 15	95.9	8000	1540	1930	10735	1656	5296	4235	3335	3947
SLSF ADDITION			+960			+960		+330			

NOTE: (1) Do not use catalogue drawings for pre-fabrication. Dimensions and weights are subject to change.
 (2) Adequate spacing must be allowed for unobstructed airflow and access to the unit. Refer to the MT Layout Guidelines section of this brochure.
 (3) An adequately sized bleed line must be installed in the cooling tower system to prevent build-up of impurities in the recirculated water.
 (4) Contact your local EVAPCO sales representative for thermal selection and pricing.

Box Size: 11x11

CONNECTION DESCRIPTION	CONNECTION (QTY) SIZE IN MM
	MTT 111-2111 TO 111-4M11
SYSTEM FLUID IN (INLET)	(1) 200
SYSTEM FLUID OUT (OUTLET)	(1) 200
MAKE-UP (MU)	(1) 50
OVERFLOW (OF)	(1) 50
DRAIN (D)	(1) 50

MTT 111-2111 TO 111-4M11

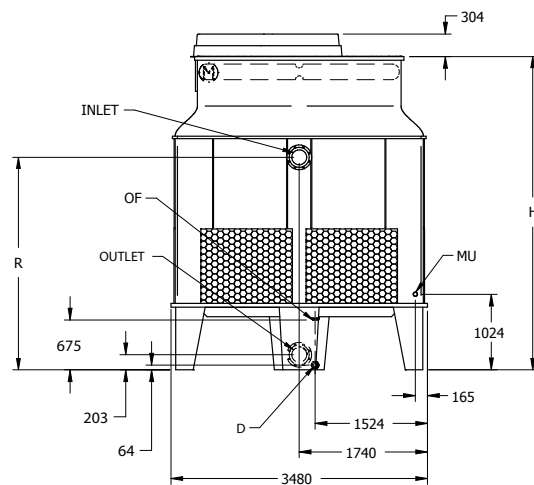
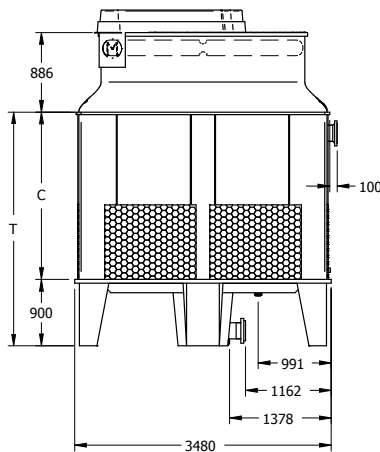
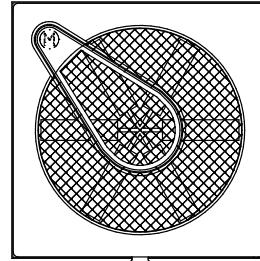

Table 12 Engineering Data

Model No.	Fan		Weights (Kg)				Operating Basin Volume (L)	Dimensions (mm)			
	Fan Motor (kW)	Air Flow (m ³ /s)	Shipping	Shipping Heaviest Section	Rigging Heaviest Section	Operating		H	T	C	R
MTT 111-2111	7.5	32.6	2725	1680	1300	3865	686	4248	3168	2268	2880
MTT 111-2J11	11	37.1	2785	1680	1300	3925	686	4248	3168	2268	2880
MTT 111-2K11	15	40.6	2810	1680	1300	3950	686	4248	3168	2268	2880
MTT 111-3111	7.5	32	2915	1595	1890	4055	686	4553	3472	2572	3185
MTT 111-3J11	11	36.4	2975	1595	1950	4115	686	4553	3472	2572	3185
MTT 111-3K11	15	39.9	3005	1595	1980	4140	686	4553	3472	2572	3185
MTT 111-3L11	18.5	42.8	3015	1595	1990	4155	686	4553	3472	2572	3185
MTT 111-4111	7.5	31.5	3105	1785	2080	4245	686	4858	3777	2877	3490
MTT 111-4J11	11	35.8	3165	1785	2140	4305	686	4858	3777	2877	3490
MTT 111-4K11	15	39.2	3195	1785	2170	4330	686	4858	3777	2877	3490
MTT 111-4L11	18.5	42.1	3205	1785	2180	4345	686	4858	3777	2877	3490
MTT 111-4M11	22	44.6	3230	1785	2205	4370	686	4858	3777	2877	3490
SLSF ADDITION			+320			+320		+330			

- NOTE: (1) Do not use catalogue drawings for pre-fabrication. Dimensions and weights are subject to change.
 (2) Adequate spacing must be allowed for unobstructed airflow and access to the unit. Refer to the MT Layout Guidelines section of this brochure.
 (3) An adequately sized bleed line must be installed in the cooling tower system to prevent build-up of impurities in the recirculated water.
 (4) Contact your local EVAPCO sales representative for thermal selection and pricing.

ENGINEERING DATA AND DIMENSIONS

MTT

Box Size: 11x22

CONNECTION DESCRIPTION	CONNECTION (QTY) SIZE IN MM
	MTT 211-2I22 TO 211-4M22
SYSTEM FLUID IN (INLET)	(2) 200
SYSTEM FLUID OUT (OUTLET)	(2) 200
MAKE-UP (MU)	(2) 50
OVERFLOW (OF)	(2) 50
DRAIN (D)	(2) 50
EQUALIZER (E)	(2) 250

MTT 211-2I22 TO 211-4M22

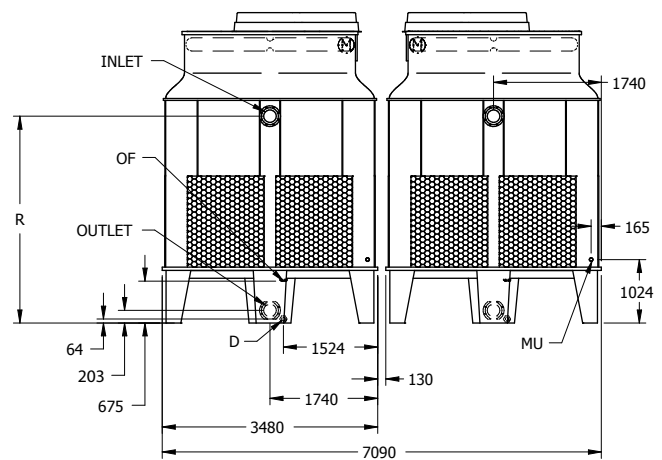
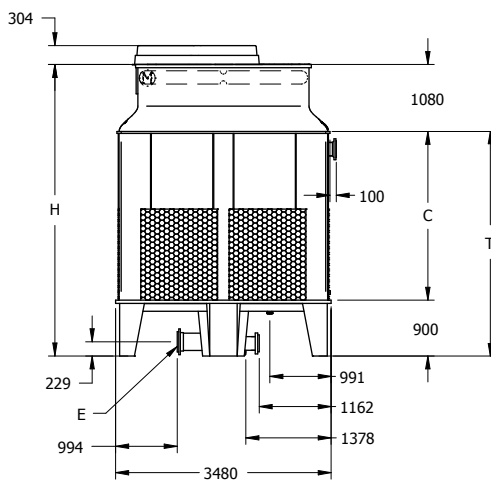
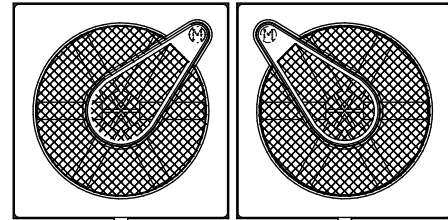

Table 13 Engineering Data

Model No.	Fan		Weights (Kg)				Operating Basin Volume (L)	Dimensions (mm)			
	Fan Motor (kW)	Air Flow (m³/s)	Shipping	Shipping Heaviest Section	Rigging Heaviest Section	Operating		H	T	C	R
MTT 211-2I22	(2) 7.5	65.1	5770	1555	1850	8045	1372	4705	3626	2726	3337
MTT 211-2J22	(2) 11	74.1	5890	1555	1910	8165	1372	4705	3626	2726	3337
MTT 211-2K22	(2) 15	81.1	5940	1555	1935	8220	1372	4705	3626	2726	3337
MTT 211-3I22	(2) 7.5	64.1	6150	1745	2040	8430	1372	5010	3930	3030	3642
MTT 211-3J22	(2) 11	72.9	6270	1745	2100	8545	1372	5010	3930	3030	3642
MTT 211-3K22	(2) 15	79.7	6325	1745	2125	8600	1372	5010	3930	3030	3642
MTT 211-3L22	(2) 18.5	85.5	6350	1745	2140	8625	1372	5010	3930	3030	3642
MTT 211-4I22	(2) 7.5	63	6525	1930	2225	8800	1372	5315	4235	3335	3947
MTT 211-4J22	(2) 11	71.6	6640	1930	2285	8920	1372	5315	4235	3335	3947
MTT 211-4K22	(2) 15	78.4	6695	1930	2315	8970	1372	5315	4235	3335	3947
MTT 211-4L22	(2) 18.5	84.2	6720	1930	2325	9000	1372	5315	4235	3335	3947
MTT 211-4M22	(2) 22	89.1	6770	1930	2350	9045	1372	5315	4235	3335	3947
SLSF ADDITION			+640			+640		+330			

- NOTE: (1) Do not use catalogue drawings for pre-fabrication. Dimensions and weights are subject to change.
 (2) Adequate spacing must be allowed for unobstructed airflow and access to the unit. Refer to the MT Layout Guidelines section of this brochure.
 (3) An adequately sized bleed line must be installed in the cooling tower system to prevent build-up of impurities in the recirculated water.
 (4) Contact your local EVAPCO sales representative for thermal selection and pricing.

Box Size: 11x33

CONNECTION DESCRIPTION	CONNECTION (QTY) SIZE IN MM
	MTT 311-2I33 TO 311-4M33
SYSTEM FLUID IN (INLET)	(3) 200
SYSTEM FLUID OUT (OUTLET)	(3) 200
MAKE-UP (MU)	(3) 50
OVERFLOW (OF)	(3) 50
DRAIN (D)	(3) 50
EQUALIZER (E)	(3) 250

MTT 311-2I33 TO 311-4M33

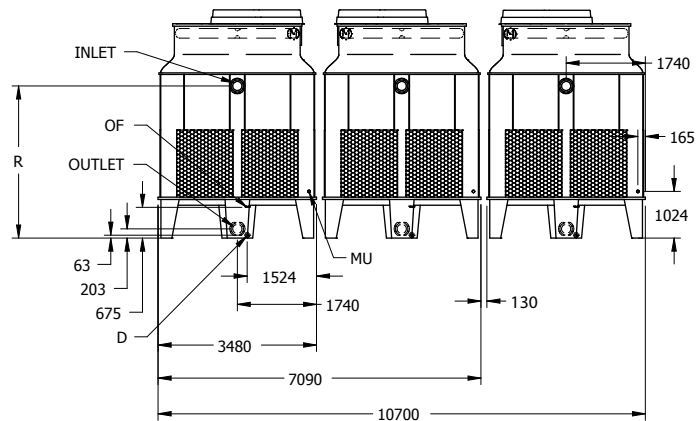
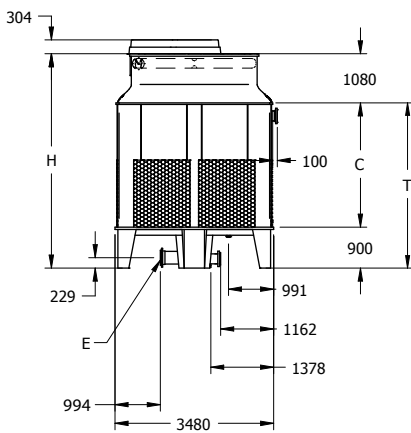
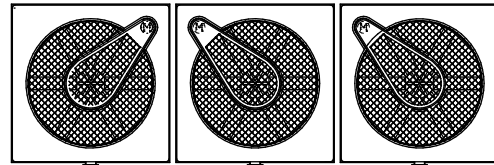

Table 14 Engineering Data

Model No.	Fan		Weights (Kg)				Operating Basin Volume (L)	Dimensions (mm)			
	Fan Motor (kW)	Air Flow (m³/s)	Shipping	Shipping Heaviest Section	Rigging Heaviest Section	Operating		H	T	C	R
MTT 311-2I33	(3) 7.5	97.7	8655	1555	1850	12070	2058	4705	3626	2726	3337
MTT 311-2J33	(3) 11	111.2	8830	1555	1910	12245	2058	4705	3626	2726	3337
MTT 311-2K33	(3) 15	121.8	8915	1555	1935	12330	2058	4705	3626	2726	3337
MTT 311-3I33	(3) 7.5	96.1	9225	1745	2040	12640	2058	5010	3930	3030	3642
MTT 311-3J33	(3) 11	109.4	9405	1745	2100	12820	2058	5010	3930	3030	3642
MTT 311-3K33	(3) 15	119.7	9485	1745	2125	12900	2058	5010	3930	3030	3642
MTT 311-3L33	(3) 18.5	128.4	9525	1745	2140	12940	2058	5010	3930	3030	3642
MTT 311-4I33	(3) 7.5	94.5	9785	1930	2225	13200	2058	5315	4235	3335	3947
MTT 311-4J33	(3) 11	107.5	9960	1930	2285	13375	2058	5315	4235	3335	3947
MTT 311-4K33	(3) 15	117.8	10045	1930	2315	13460	2058	5315	4235	3335	3947
MTT 311-4L33	(3) 18.5	126.4	10085	1930	2325	13500	2058	5315	4235	3335	3947
MTT 311-4M33	(3) 22	133.8	10150	1930	2350	13565	2058	5315	4235	3335	3947
SLSF ADDITION			+960			+960		+330			

- NOTE: (1) Do not use catalogue drawings for pre-fabrication. Dimensions and weights are subject to change.
 (2) Adequate spacing must be allowed for unobstructed airflow and access to the unit. Refer to the MT Layout Guidelines section of this brochure.
 (3) An adequately sized bleed line must be installed in the cooling tower system to prevent build-up of impurities in the recirculated water.
 (4) Contact your local EVAPCO sales representative for thermal selection and pricing.

ENGINEERING DATA AND DIMENSIONS



Box Size: 11x16

CONNECTION DESCRIPTION	CONNECTION (QTY) SIZE IN MM
	MTT 111-2I16 TO 111-4N16
SYSTEM FLUID IN (INLET)	(1) 250
SYSTEM FLUID OUT (OUTLET)	(1) 250
MAKE-UP (MU)	(1) 80
OVERFLOW (OF)	(1) 80
DRAIN (D)	(2) 50

MTT 111-2I16 TO 111-4N16

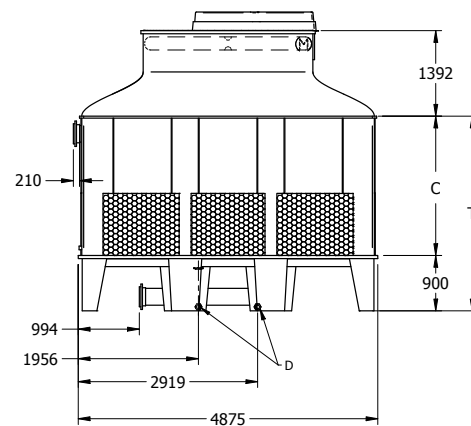
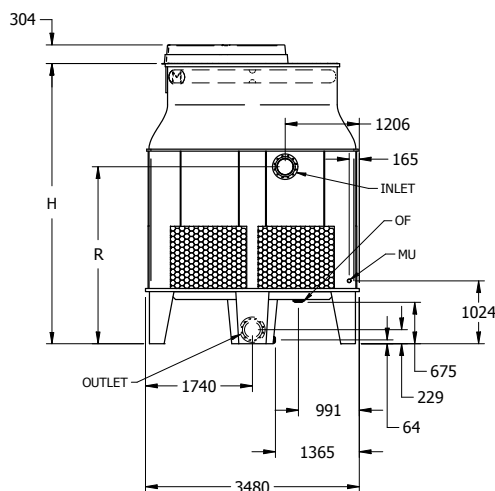
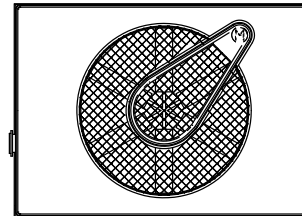

Table 15 Engineering Data

Model No.	Fan		Weights (Kg)				Operating Basin Volume (L)	Dimensions (mm)			
	Fan Motor (kW)	Air Flow (m³/s)	Shipping	Shipping Heaviest Section	Rigging Heaviest Section	Operating		H	T	C	R
MTT 111-2I16	7.5	40.6	4560	2290	2420	6030	1354	4562	3169	2269	2880
MTT 111-2J16	11	46.2	4620	2325	2480	6085	1354	4562	3169	2269	2880
MTT 111-2K16	15	50.6	4645	2355	2510	6115	1354	4562	3169	2269	2880
MTT 111-2L16	18.5	54.3	4660	2370	2520	6130	1354	4562	3169	2269	2880
MTT 111-2M16	22	57.6	4680	2390	2545	6150	1354	4562	3169	2269	2880
MTT 111-3I16	7.5	40	4815	2550	2680	6285	1354	4867	3473	2573	3185
MTT 111-3J16	11	45.5	4875	2550	2740	6345	1354	4867	3473	2573	3185
MTT 111-3K16	15	49.8	4905	2550	2765	6375	1354	4867	3473	2573	3185
MTT 111-3L16	18.5	53.4	4915	2550	2780	6385	1354	4867	3473	2573	3185
MTT 111-3M16	22	56.5	4940	2550	2805	6410	1354	4867	3473	2573	3185
MTT 111-3N16	30	61.9	5015	2550	2880	6485	1354	4867	3473	2573	3185
MTT 111-4I16	7.5	39.3	5070	2805	2935	6540	1354	5172	3778	2878	3489
MTT 111-4J16	11	44.7	5130	2805	2995	6600	1354	5172	3778	2878	3489
MTT 111-4K16	15	49	5155	2805	3020	6625	1354	5172	3778	2878	3489
MTT 111-4L16	18.5	52.5	5170	2805	3035	6640	1354	5172	3778	2878	3489
MTT 111-4M16	22	55.6	5195	2805	3055	6665	1354	5172	3778	2878	3489
MTT 111-4N16	30	60.9	5270	2805	3135	6740	1354	5172	3778	2878	3489
SLSF ADDITION			+320			+320		+330			

- NOTE: (1) Do not use catalogue drawings for pre-fabrication. Dimensions and weights are subject to change.
 (2) Adequate spacing must be allowed for unobstructed airflow and access to the unit. Refer to the MT Layout Guidelines section of this brochure.
 (3) An adequately sized bleed line must be installed in the cooling tower system to prevent build-up of impurities in the recirculated water.
 (4) Contact your local EVAPCO sales representative for thermal selection and pricing.
 (5) CTI certification pending for the models shown on this page (expected 2018 Q1).

Box Size: 22x16

CONNECTION DESCRIPTION	CONNECTION (QTY) SIZE IN MM
	MTT 222-2I16 TO 222-4N16
SYSTEM FLUID IN (INLET)	(2) 250
SYSTEM FLUID OUT (OUTLET)	(2) 250
MAKE-UP (MU)	(2) 80
OVERFLOW (OF)	(2) 80
DRAIN (D)	(4) 50
EQUALIZER (E)	(2) 300

MTT 222-2I16 to 222-4N16

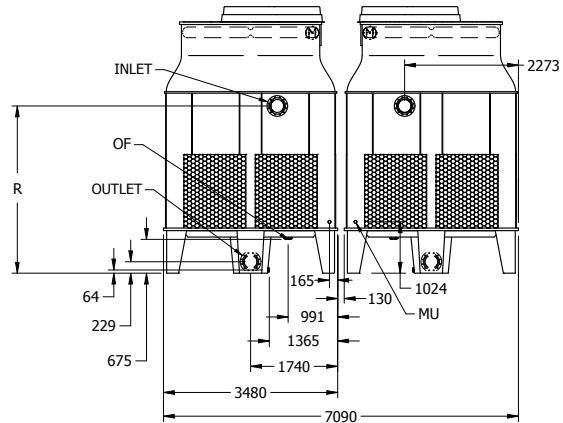
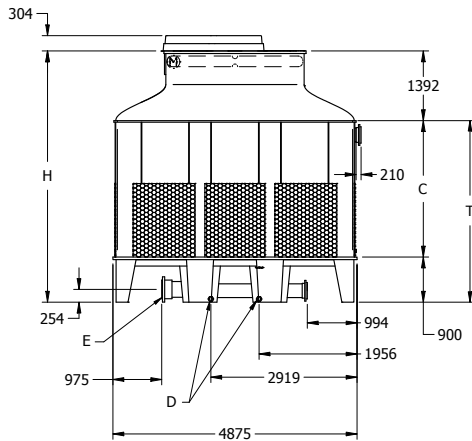
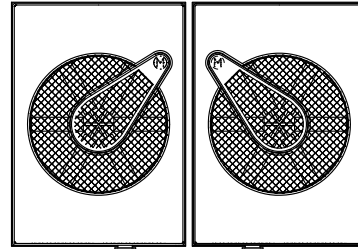

Table 16 Engineering Data

Model No.	Fan		Weights (Kg)				Operating Basin Volume (L)	Dimensions (mm)			
	Fan Motor (kW)	Air Flow (m³/s)	Shipping	Shipping Heaviest Section	Rigging Heaviest Section	Operating		H	T	C	R
MTT 222-2I16	(3) 7.5	121.8	14370	2520	2655	15675	2708	5020	3626	2726	3337
MTT 222-2J16	(3) 11	138.5	14545	2520	2710	15855	2708	5020	3626	2726	3337
MTT 222-2K16	(3) 15	151.8	14630	2520	2740	15935	2708	5020	3626	2726	3337
MTT 222-2L16	(3) 18.5	163	14670	2520	2755	15975	2708	5020	3626	2726	3337
MTT 222-2M16	(3) 22	172.8	14735	2520	2775	16045	2708	5020	3626	2726	3337
MTT 222-3I16	(3) 7.5	119.9	15145	2780	2910	16450	2708	5324	3931	3031	3642
MTT 222-3J16	(3) 11	136.4	15320	2780	2970	16630	2708	5324	3931	3031	3642
MTT 222-3K16	(3) 15	149.4	15405	2780	3000	16710	2708	5324	3931	3031	3642
MTT 222-3L16	(3) 18.5	160.1	15445	2780	3010	16750	2708	5324	3931	3031	3642
MTT 222-3M16	(3) 22	169.6	15515	2780	3035	16820	2708	5324	3931	3031	3642
MTT 222-3N16	(3) 30	185.6	15745	2780	3110	17050	2708	5324	3931	3031	3642
MTT 222-4I16	(3) 7.5	118	15920	3040	3170	17225	2708	5629	4235	3335	3947
MTT 222-4J16	(3) 11	134.1	16100	3040	3230	17405	2708	5629	4235	3335	3947
MTT 222-4K16	(3) 15	147	16180	3040	3255	17485	2708	5629	4235	3335	3947
MTT 222-4L16	(3) 18.5	157.6	16220	3040	3270	17525	2708	5629	4235	3335	3947
MTT 222-4M16	(3) 22	166.9	16290	3040	3295	17595	2708	5629	4235	3335	3947
MTT 222-4N16	(3) 30	182.7	16520	3040	3370	17825	2708	5629	4235	3335	3947
SLSF ADDITION			+640			+640		+330			

- NOTE: (1) Do not use catalogue drawings for pre-fabrication. Dimensions and weights are subject to change.
 (2) Adequate spacing must be allowed for unobstructed airflow and access to the unit. Refer to the MT Layout Guidelines section of this brochure.
 (3) An adequately sized bleed line must be installed in the cooling tower system to prevent build-up of impurities in the recirculated water.
 (4) Contact your local EVAPCO sales representative for thermal selection and pricing.
 (5) CTI certification pending for the models shown on this page (expected 2018 Q1).

ENGINEERING DATA AND DIMENSIONS



Box Size: 11x32

CONNECTION DESCRIPTION	CONNECTION (QTY) SIZE IN MM
	MTT 211-2I32 TO 211-4N32
SYSTEM FLUID IN (INLET)	(2) 250
SYSTEM FLUID OUT (OUTLET)	(2) 250
MAKE-UP (MU)	(2) 80
OVERFLOW (OF)	(2) 80
DRAIN (D)	(4) 50
EQUALIZER (E)	(2) 300

MTT 211-2I32 to 211-4N32

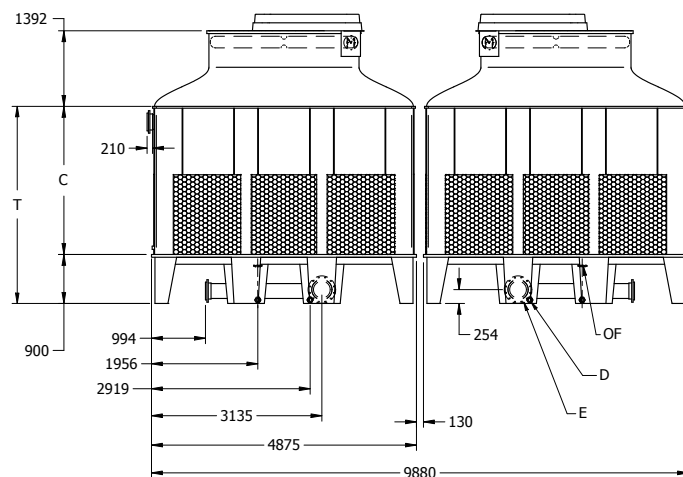
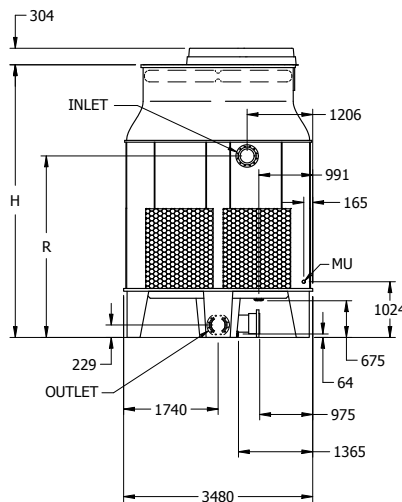
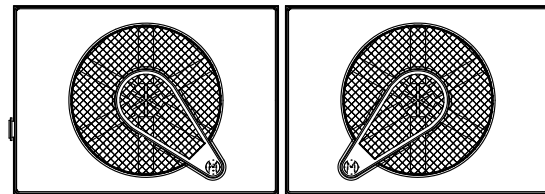

Table 17 Engineering Data

Model No.	Fan		Weights (Kg)				Operating Basin Volume (L)	Dimensions (mm)			
	Fan Motor (kW)	Air Flow (m³/s)	Shipping	Shipping Heaviest Section	Rigging Heaviest Section	Operating		H	T	C	R
MTT 211-2I32	(2) 7.5	81.2	9580	2520	2655	12520	2708	5020	3626	2726	3337
MTT 211-2J32	(2) 11	92.3	9700	2520	2710	12635	2708	5020	3626	2726	3337
MTT 211-2K32	(2) 15	101.2	9750	2520	2740	12690	2708	5020	3626	2726	3337
MTT 211-2L32	(2) 18.5	108.7	9780	2520	2755	12720	2708	5020	3626	2726	3337
MTT 211-2M32	(2) 22	115.2	9825	2520	2775	12765	2708	5020	3626	2726	3337
MTT 211-3I32	(2) 7.5	80	10095	2780	2910	13035	2708	5324	3931	3031	3642
MTT 211-3J32	(2) 11	90.9	10215	2780	2970	13155	2708	5324	3931	3031	3642
MTT 211-3K32	(2) 15	99.6	10270	2780	3000	13210	2708	5324	3931	3031	3642
MTT 211-3L32	(2) 18.5	106.8	10295	2780	3010	13235	2708	5324	3931	3031	3642
MTT 211-3M32	(2) 22	113.1	10340	2780	3035	13280	2708	5324	3931	3031	3642
MTT 211-3N32	(2) 30	123.8	10495	2780	3110	13435	2708	5324	3931	3031	3642
MTT 211-4I32	(2) 7.5	78.6	10615	3040	3170	13555	2708	5629	4235	3335	3947
MTT 211-4J32	(2) 11	89.4	10730	3040	3230	13670	2708	5629	4235	3335	3947
MTT 211-4K32	(2) 15	98	10785	3040	3255	13725	2708	5629	4235	3335	3947
MTT 211-4L32	(2) 18.5	105.1	10815	3040	3270	13755	2708	5629	4235	3335	3947
MTT 211-4M32	(2) 22	111.3	10860	3040	3295	13800	2708	5629	4235	3335	3947
MTT 211-4N32	(2) 30	121.8	11015	3040	3370	13955	2708	5629	4235	3335	3947
SLSF ADDITION			+640			+640		+330			

- NOTE: (1) Do not use catalogue drawings for pre-fabrication. Dimensions and weights are subject to change.
 (2) Adequate spacing must be allowed for unobstructed airflow and access to the unit. Refer to the MT Layout Guidelines section of this brochure.
 (3) An adequately sized bleed line must be installed in the cooling tower system to prevent build-up of impurities in the recirculated water.
 (4) Contact your local EVAPCO sales representative for thermal selection and pricing.
 (5) CTI certification pending for the models shown on this page (expected 2018 Q1).

Box Size: 12x12

CONNECTION DESCRIPTION	CONNECTION (QTY) SIZE IN MM
	MTT 112-2I12 TO 112-4N12
SYSTEM FLUID IN (INLET)	(1) 200
SYSTEM FLUID OUT (OUTLET)	(1) 200
MAKE-UP (MU)	(1) 50
OVERFLOW (OF)	(1) 50
DRAIN (D)	(1) 50

MTT 112-2I12 TO 112-4N12

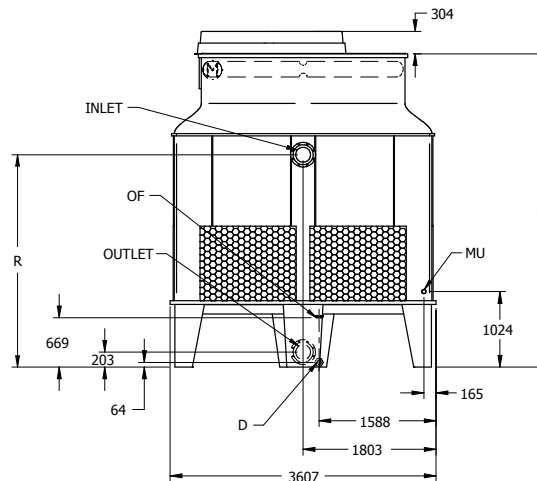
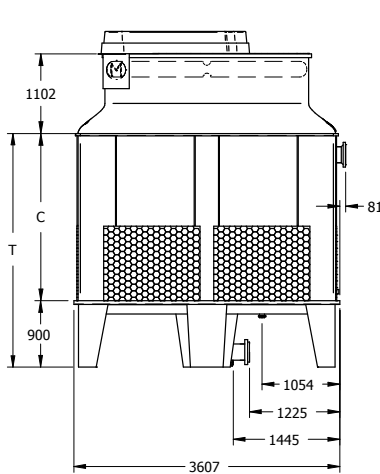
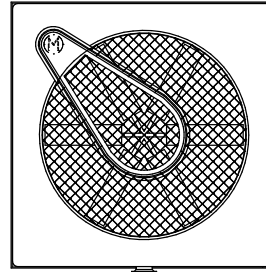

Table 18 Engineering Data

Model No.	Fan		Weights (Kg)				Operating Basin Volume (L)	Dimensions (mm)			
	Fan Motor (kW)	Air Flow (m ³ /s)	Shipping	Shipping Heaviest Section	Rigging Heaviest Section	Operating		H	T	C	R
MTT 112-2I12	7.5	33.7	2810	1750	1370	4030	693	4248	3168	2268	2880
MTT 112-2J12	11	38.4	2870	1750	1370	4090	693	4248	3168	2268	2880
MTT 112-2K12	15	42.0	2900	1750	1370	4120	693	4248	3168	2268	2880
MTT 112-2L12	18.5	45.1	2910	1750	1370	4130	693	4248	3168	2268	2880
MTT 112-2M12	22	47.8	2935	1750	1370	4155	693	4248	3168	2268	2880
MTT 112-3I12	7.5	33.2	3005	1670	1965	4225	693	4553	3472	2572	3185
MTT 112-3J12	11	37.7	3070	1670	2030	4290	693	4553	3472	2572	3185
MTT 112-3K12	15	41.3	3100	1670	2055	4320	693	4553	3472	2572	3185
MTT 112-3L12	18.5	44.3	3110	1670	2070	4330	693	4553	3472	2572	3185
MTT 112-3M12	22	46.9	3135	1670	2090	4355	693	4553	3472	2572	3185
MTT 112-4I12	7.5	32.6	3205	1870	2165	4425	693	4858	3777	2877	3490
MTT 112-4J12	11	37.1	3270	1870	2225	4490	693	4858	3777	2877	3490
MTT 112-4K12	15	40.6	3300	1870	2255	4520	693	4858	3777	2877	3490
MTT 112-4L12	18.5	43.6	3310	1870	2270	4530	693	4858	3777	2877	3490
MTT 112-4M12	22	46.2	3335	1870	2290	4555	693	4858	3777	2877	3490
MTT 112-4N12	30	50.6	3415	1870	2370	4635	693	4858	3777	2877	3490
SLSF ADDITION			+320			+320		+330			

- NOTE: (1) Do not use catalogue drawings for pre-fabrication. Dimensions and weights are subject to change.
 (2) Adequate spacing must be allowed for unobstructed airflow and access to the unit. Refer to the MT Layout Guidelines section of this brochure.
 (3) An adequately sized bleed line must be installed in the cooling tower system to prevent build-up of impurities in the recirculated water.
 (4) Contact your local EVAPCO sales representative for thermal selection and pricing.

ENGINEERING DATA AND DIMENSIONS

MTT

Box Size: 16x16

CONNECTION DESCRIPTION	CONNECTION (QTY) SIZE IN MM
	MTT 116-2L16 TO 116-4O16
SYSTEM FLUID IN (INLET)	(1) 300
SYSTEM FLUID OUT (OUTLET)	(1) 300
MAKE-UP (MU)	(1) 80
OVERFLOW (OF)	(1) 80
DRAIN (D)	(1) 80

MTT 116-2L16 TO 116-4O16

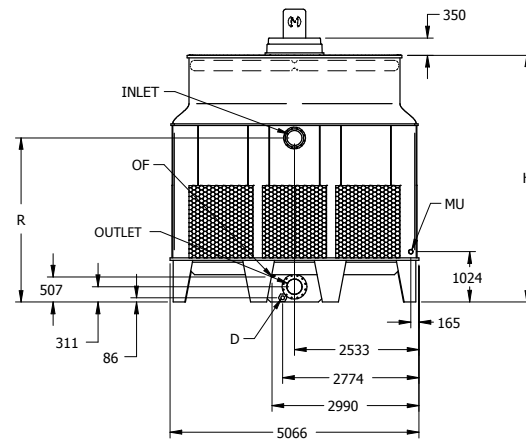
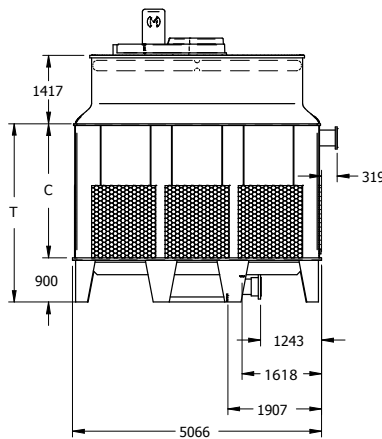
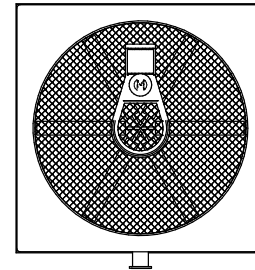

Table 19 Engineering Data

Model No.	Fan		Weights (Kg)				Operating Basin Volume (L)	Dimensions (mm)			
	Fan Motor (kW)	Air Flow (m³/s)	Shipping	Shipping Heaviest Section	Rigging Heaviest Section	Operating		H	T	C	R
MTT 116-2L16	18.5	69.3	6445	3345	3845	9410	2011	5020	3625	2725	3337
MTT 116-2M16	22	73.5	6475	3345	3875	9440	2011	5020	3625	2725	3337
MTT 116-2N16	30	80.7	6550	3345	3950	9515	2011	5020	3625	2725	3337
MTT 116-3L16	18.5	68.2	6820	3720	4225	9790	2011	5324	3930	3030	3642
MTT 116-3M16	22	72.3	6850	3720	4250	9815	2011	5324	3930	3030	3642
MTT 116-3N16	30	79.3	6925	3720	4325	9895	2011	5324	3930	3030	3642
MTT 116-3O16	37	85.2	6930	3720	4330	9895	2011	5324	3930	3030	3642
MTT 116-4L16	18.5	67	7205	4100	4605	10170	2011	5629	4234	3334	3947
MTT 116-4M16	22	71	7230	4100	4630	10195	2011	5629	4234	3334	3947
MTT 116-4N16	30	78	7305	4100	4710	10275	2011	5629	4234	3334	3947
MTT 116-4O16	37	83.8	7310	4100	4715	10280	2011	5629	4234	3334	3947

NOTE: (1) Do not use catalogue drawings for pre-fabrication. Dimensions and weights are subject to change.
 (2) Adequate spacing must be allowed for unobstructed airflow and access to the unit. Refer to the MT Layout Guidelines section of this brochure.
 (3) An adequately sized bleed line must be installed in the cooling tower system to prevent build-up of impurities in the recirculated water.
 (4) Contact your local EVAPCO sales representative for thermal selection and pricing.

Box Size: 16x20

CONNECTION DESCRIPTION	CONNECTION (QTY) SIZE IN MM
	MTT 116-2L20 TO 116-4Q20
SYSTEM FLUID IN (INLET)	(1) 350
SYSTEM FLUID OUT (OUTLET)	(1) 350
MAKE-UP (MU)	(1) 80
OVERFLOW (OF)	(1) 80
DRAIN (D)	(1) 80

MTT 116-2L20 to 116-4Q20

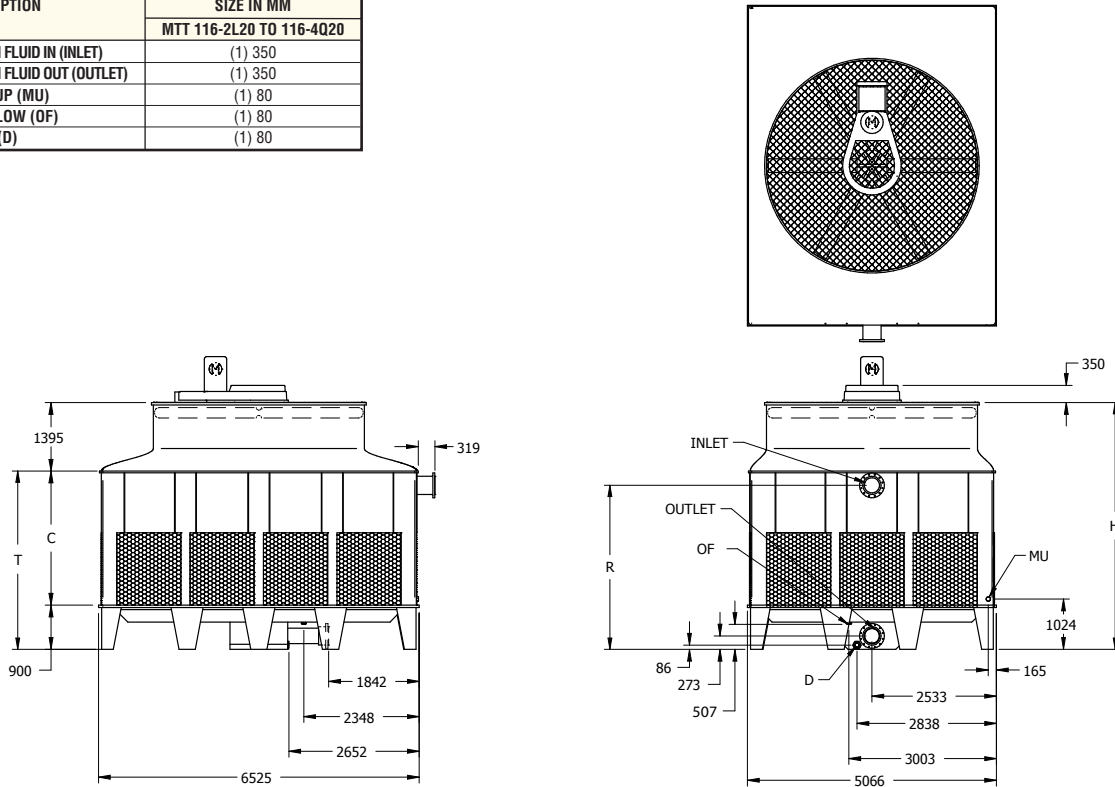

Table 20 Engineering Data

Model No.	Fan		Weights (Kg)				Operating Basin Volume (L)	Dimensions (mm)			
	Fan Motor (kW)	Air Flow (m³/s)	Shipping	Shipping Heaviest Section	Rigging Heaviest Section	Operating		H	T	C	R
MTT 116-2L20	18.5	82.8	8010	4205	4720	11890	2418	5020	3625	2725	3337
MTT 116-2M20	22	87.8	8035	4205	4745	11910	2418	5020	3625	2725	3337
MTT 116-2N20	30	96.4	8110	4205	4820	11990	2418	5020	3625	2725	3337
MTT 116-3L20	18.5	81.5	8495	4690	5205	12375	2418	5324	3930	3030	3642
MTT 116-3M20	22	86.4	8520	4690	5230	12395	2418	5324	3930	3030	3642
MTT 116-3N20	30	94.8	8595	4690	5305	12475	2418	5324	3930	3030	3642
MTT 116-3O20	37	101.9	8600	4690	5310	12480	2418	5324	3930	3030	3642
MTT 116-4L20	18.5	80.1	8970	5165	5685	12850	2418	5629	4234	3334	3947
MTT 116-4M20	22	85	8995	5165	5705	12875	2418	5629	4234	3334	3947
MTT 116-4N20	30	93.2	9070	5165	5785	12950	2418	5629	4234	3334	3947
MTT 116-4O20	37	100.2	9075	5165	5790	12955	2418	5629	4234	3334	3947
MTT 116-4P20	45	106.2	9235	5165	5945	13115	2418	5629	4234	3334	3947
MTT 116-4Q20	55	114.2	9295	5165	6005	13170	2418	5629	4234	3334	3947

- NOTE: (1) Do not use catalogue drawings for pre-fabrication. Dimensions and weights are subject to change.
 (2) Adequate spacing must be allowed for unobstructed airflow and access to the unit. Refer to the MT Layout Guidelines section of this brochure.
 (3) An adequately sized bleed line must be installed in the cooling tower system to prevent build-up of impurities in the recirculated water.
 (4) Contact your local EVAPCO sales representative for thermal selection and pricing.

ENGINEERING DATA AND DIMENSIONS

MTT

Box Size: 20x20

CONNECTION DESCRIPTION	CONNECTION (QTY) SIZE IN MM
	MTT 120-3N20 TO 120-4Q20
SYSTEM FLUID IN (INLET)	(1) 350
SYSTEM FLUID OUT (OUTLET)	(1) 350
MAKE-UP (MU)	(1) 80
OVERFLOW (OF)	(1) 80
DRAIN (D)	(1) 80

MTT 120-3N20 TO 120-4Q20

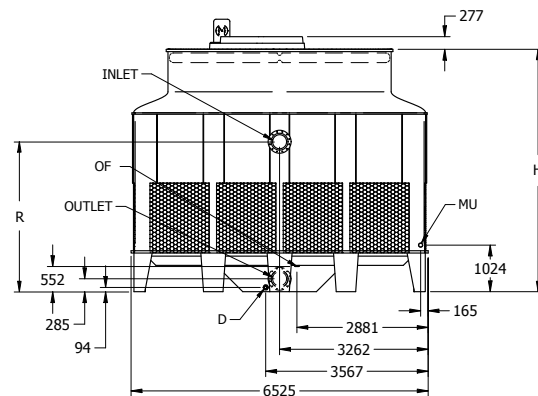
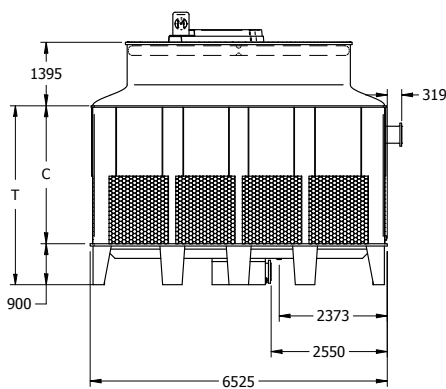
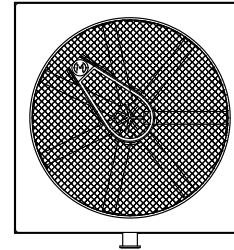

Table 21 Engineering Data

Model No.	Fan		Weights (Kg)				Operating Basin Volume (L)	Dimensions (mm)			
	Fan Motor (kW)	Air Flow (m³/s)	Shipping	Shipping Heaviest Section	Rigging Heaviest Section	Operating		H	T	C	R
MTT 120-3N20	30	112.9	9750	5365	6440	16160	3594	5324	3930	3030	3642
MTT 120-3O20	37	121.3	9755	5365	6445	16165	3594	5324	3930	3030	3642
MTT 120-3P20	45	128.7	9850	5365	6540	16260	3594	5324	3930	3030	3642
MTT 120-3Q20	55	138.2	9910	5365	6600	16320	3594	5324	3930	3030	3642
MTT 120-4N20	30	111.0	10365	5980	7055	16775	3594	5629	4234	3334	3947
MTT 120-4O20	37	119.3	10370	5980	7060	16780	3594	5629	4234	3334	3947
MTT 120-4P20	45	126.5	10465	5980	7155	16875	3594	5629	4234	3334	3947
MTT 120-4Q20	55	135.9	10525	5980	7210	16935	3594	5629	4234	3334	3947

- NOTE: (1) Do not use catalogue drawings for pre-fabrication. Dimensions and weights are subject to change.
 (2) Adequate spacing must be allowed for unobstructed airflow and access to the unit. Refer to the MT Layout Guidelines section of this brochure.
 (3) An adequately sized bleed line must be installed in the cooling tower system to prevent build-up of impurities in the recirculated water.
 (4) Contact your local EVAPCO sales representative for thermal selection and pricing.

MTT

MAINTENANCE ACCESSORIES

Standard and Optional Maintenance Features

Routine maintenance is the key to a long lasting cooling tower. EVAPCO offers features and accessories to complement the robust design of the MTT. The two main areas that require easy access for routine maintenance are the motor & drive assembly and the cold water basin.



Drive System Ladder and Platform Package

All units 2.4m and wider can be provided with an access ladder & platform package. The platform provides access to the motor and lubrication lines for motors checks and maintenance. Where required, EVAPCO is able to provide safety cages for the ladder. The ladder and platform assembly provided are in accordance with AS 1657.



Access Door(s)

EVAPCO's MTT provides one man-sized access door for maintenance as standard. The access door is designed such that the fill blocks and drift eliminators can be easily removed and replaced for cleaning. Additional access door may be added subject to approval from the factory, contact your local EVAPCO sales representative for more information.



Quick Release Fasteners for Louvers

The MTT basin is accessible from all four (4) sides (depending on layout) via the air inlet louvers. Each louver has two (2) quick release fasteners that remain on the unit when loosened. Lift and remove the light weight louvers for full access to the basin.



Sump Sweeper Piping

Set up around the perimeter of the basin, the MTT's sump sweeper piping with high flow eductors, washes the debris toward the sump outlet. The high flow eductor nozzles facilitate in pan cleaning. The system contains one inlet and one outlet connection. Filters, mechanical separators, external piping or controls are not included. Contact your local EVAPCO sales representative for flow rate recommendations.

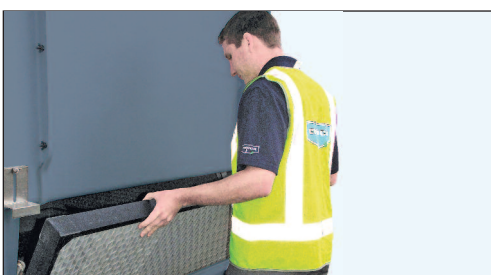

Easy Basin Access

The cold water basin section is easily accessible from ground level by simply loosening the two (2) quick release fasteners on the inlet louver assembly surrounding the cooling tower and lifting out the light weight louver. The basin can be accessed from all four (4) sides of the cooling tower.

PIER SUPPORT LAYOUT

MTT

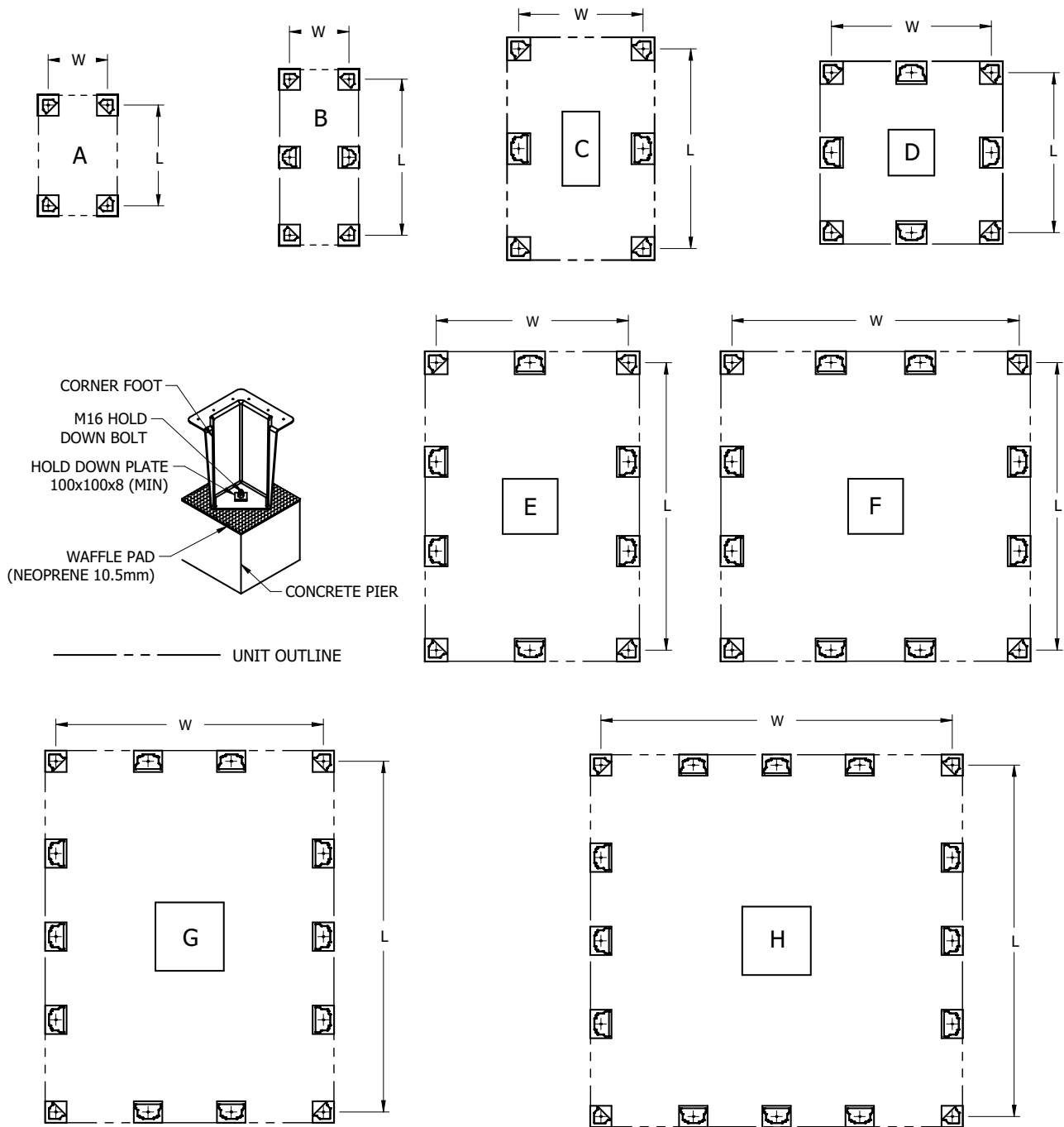

Box size	Diagram	Model	Dimension (mm)	
			W	L
4x6	A	MTT 14-2F6 to MTT 14-3G6	973	1649
4x9	B	MTT 14-2E9 to MTT 14-3F9	973	2554
8x8	A	MTT 18-2G8 to MTT 18-4J8	2013	2013
8x12	C	MTT 18-2H12 to MTT 18-4L12	2013	3232
10x10	D	MTT 110-2G10 to MTT 110-4K10	2016	2016
11x11	D	MTT 111-2I11 to MTT 111-4M11	3105	3105
11x16	E	MTT 111-2I16 to MTT 111-4N16	3105	4691
12x12	D	MTT 112-2I12 to MTT 112-4N12	3232	3232
16x16	F	MTT 116-2L16 to MTT 116-4O16	4691	4691
16x20	G	MTT 116-2L20 to MTT 116-4Q20	4691	6150
20x20	H	MTT 120-3N20 to MTT 120-4Q20	6150	6150

NOTES:

- These are suggested arrangements for preliminary layout purposes. Consult your EVAPCO sales representative for factory certified pier support drawings and alternate layout arrangements.
- The recommended support for the MTT is concrete piers located under the feet and sump (where applicable).
- Piers should be level before setting the unit in place. Do not level the unit by shimming between it and the piers.
- Concrete Piers and Anchor bolts are to be furnished by others.
- All pier dimensions should be a minimum of 300mm x 500mm. All centre sump dimensions should be minimum 1200mm x 1200mm.
- Dimensions and data are subject to change without notice. Refer to the certified drawings for exact dimensions.

Single/Multiple Unit Installations

EVAPCO's induced draft, counterflow units may have air inlets located on all four sides. When the unit is located near a wall or other structure that blocks fresh air from entering the unit, consideration must be given to the clearance distance between the air inlets of the unit and this blockage. In this type of layout, air will be drawn in through the space between the unit and the wall or other structure as well as down from above. It is important to provide adequate space in front of each air inlet to ensure proper air flow and prevent air recirculation.

When more than one EVAPCO induced draft counterflow units are installed at the same location, the potential for recirculation becomes a greater concern. For installations with two or more cooling towers, the units may be placed in a variety of locations depending on site conditions and available space.

EVAPCO has developed the recommended distances for various cases of induced draft counterflow layouts. These distances have been developed to ensure that the units are provided with adequate airflow and that recirculation is minimised. Space must also be provided for piping, accessories, removal of access panels and for maintenance of the mechanical equipment.

Product improvements confirmed by factory testing and years of field experience have allowed EVAPCO to develop minimum required distances from the unit and the surrounding walls as well as between units[†]. In addition, the distances shown in the following tables are dependent on the number of surrounding walls and the number of units. Therefore, the data presented in Tables 22 and 23 show the minimum dimensions D1 through D8 required for a variety of installation cases. See the following figures that illustrate these various cases.

For layouts of multiple multi-cell units similar to Figures 12 and 14, please contact your local EVAPCO sales representative for confirmation of layout design.

CASE 1 - Single Wall/Single Unit

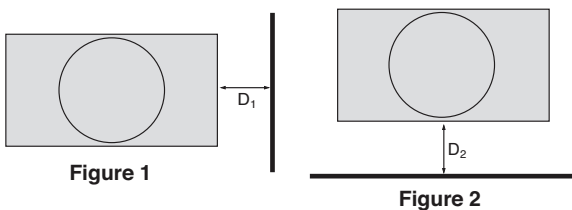

CASE 2 - No Obstructions

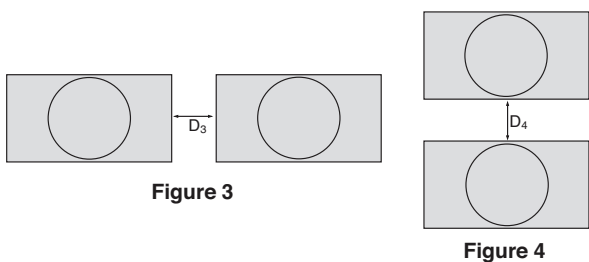

CASE 3 - Two Walls/Single Unit

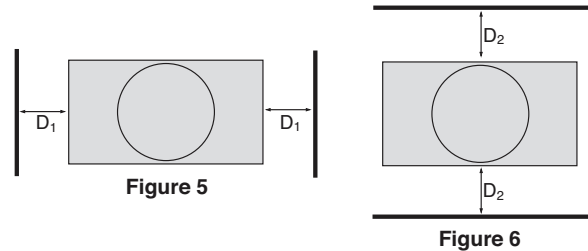

CASE 4 - Two Walls/Two Units

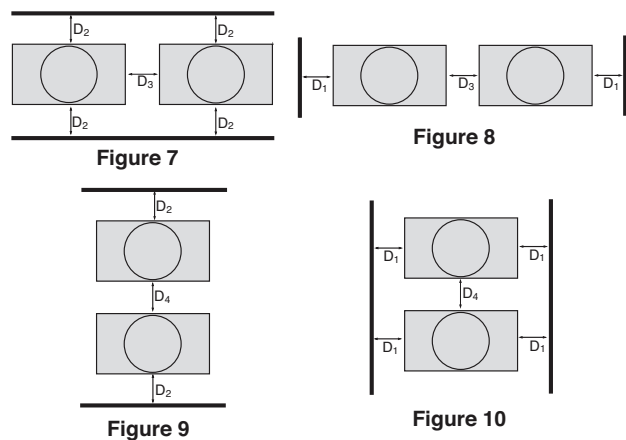

CASE 5 - Two Walls (Corner)

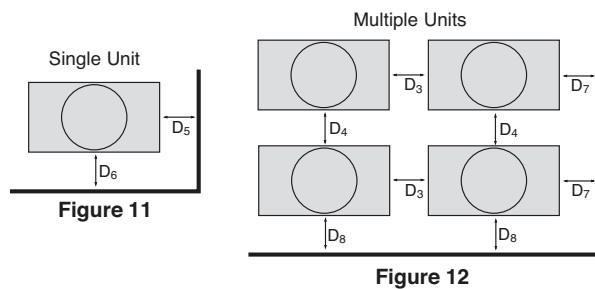

CASE 6 - Three Walls

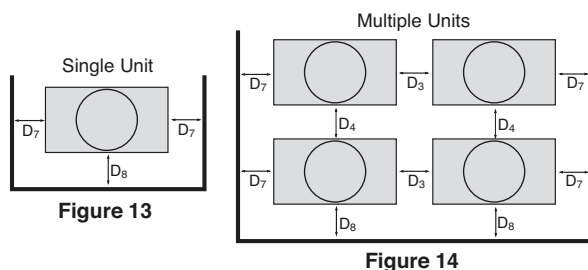

[†] The guidelines set forth in Tables 22 & 23 are to be used exclusively for EVAPCO equipment. Data from factory testing is based on air discharge velocities and air intake areas that are specific to EVAPCO equipment. Therefore, this data is NOT to be applied to other manufacturers' evaporative cooling equipment. However, any nearby equipment that is either intaking or discharging air will affect the overall layout. Please contact your local EVAPCO sales representative with any questions on how to place around other manufacturer's equipment.

MT LAYOUT GUIDELINES

Table 22 - Dimensions D1-D4

4' Wide Models

Unit Length (Ft.)	Minimum Dimensions (mm)				
	All units	All units	Towers	Cond./Coolers*	All units
	D1	D2	D3	D3	D4
4x6	610	610	610	1830	610
4x9	610	610	610	1830	610

8' Wide Models

Unit Length (Ft.)	Minimum Dimensions (mm)				
	All units	All units	Towers	Cond./Coolers*	All units
	D1	D2	D3	D3	D4
8x8	915	915	915	1830	1830
8x12	915	915	915	1830	1830
8x24	915	915	915	-	1830

10' Wide Models

Unit Length (Ft.)	Minimum Dimensions (mm)				
	All units	All units	Towers	Cond./Coolers*	All units
	D1	D2	D3	D3	D4
10x10	915	915	915	1830	1830
10x20	915	915	915	-	1830
10x30	915	915	915	-	1830

11' Wide Models

Unit Length (Ft.)	Minimum Dimensions (mm)				
	All units	All units	Towers	Cond./Coolers*	All units
	D1	D2	D3	D3	D4
11x11	915	915	915	1830	1830
11x16	915	915	915	-	1830
11x22	915	915	915	-	1830
11x32	915	915	915	-	1830
11x33	915	915	915	-	1830

12' Wide Models

Unit Length (Ft.)	Minimum Dimensions (mm)				
	All units	All units	Towers	Cond./Coolers*	All units
	D1	D2	D3	D3	D4
12x12	915	915	915	1830	1830

16' Wide Models

Unit Length (Ft.)	Minimum Dimensions (mm)				
	All units	All units	Towers	Cond./Coolers*	All units
	D1	D2	D3	D3	D4
16x8	915	915	1830	-	1830
16x12	915	915	1830	-	1830
16x16	915	915	1830	-	1830
16x20	915	915	1830	-	1830

20' Wide Models

Unit Length (Ft.)	Minimum Dimensions (mm)				
	All units	All units	Towers	Cond./Coolers*	All units
	D1	D2	D3	D3	D4
20x20	915	915	1830	-	1830

22' Wide Models

Unit Length (Ft.)	Minimum Dimensions (mm)				
	All units	All units	Towers	Cond./Coolers*	All units
	D1	D2	D3	D3	D4
22x16	915	915	1830	-	1830

24' Wide Models

Unit Length (Ft.)	Minimum Dimensions (mm)				
	All units	All units	Towers	Cond./Coolers*	All units
	D1	D2	D3	D3	D4
24x8	915	915	1830	-	1830
24x12	915	915	1830	-	1830

Table 23 - Dimensions D5-D8

4' Wide Models

Unit Length (Ft.)	Minimum Dimensions (mm)			
	D5	D6	D7	D8
4x6	610	610	610	610
4x9	610	610	610	610

8' Wide Models

Unit Length (Ft.)	Minimum Dimensions (mm)			
	D5	D6	D7	D8
8x8	915	915	915	915
8x12	915	915	915	915
8x24	915	915	915	1220

10' Wide Models

Unit Length (Ft.)	Minimum Dimensions (mm)			
	D5	D6	D7	D8
10x10	915	915	915	915
10x20	915	915	915	915
10x30	915	1065	1065	1220

11' Wide Models

Unit Length (Ft.)	Minimum Dimensions (mm)			
	D5	D6	D7	D8
11x11	915	915	915	915
11x16	915	915	915	915
11x22	915	915	915	1065
11x32	915	1065	1065	1220
11x33	915	1065	1065	1220

12' Wide Models

Unit Length (Ft.)	Minimum Dimensions (mm)			
	D5	D6	D7	D8
12x12	915	915	915	915

16' Wide Models

Unit Length (Ft.)	Minimum Dimensions (mm)			
	D5	D6	D7	D8
16x8	915	915	915	915
16x12	915	915	915	915
16x16	915	915	915	915
16x20	1220	1065	1370	1220

20' Wide Models

Unit Length (Ft.)	Minimum Dimensions (mm)			
	D5	D6	D7	D8
20x20	1220	1220	1370	1370

22' Wide Models

Unit Length (Ft.)	Minimum Dimensions (mm)			
	D5	D6	D7	D8
22x16	1220	1065	1370	1220

24' Wide Models

Unit Length (Ft.)	Minimum Dimensions (mm)			
	D5	D6	D7	D8
24x8	1220	915	1370	1370
24x12	1220	915	1370	1370

DIMENSION KEY

D1, D5, D7 - From Ends of Units D3 - Units End to End
 D2, D6, D8 - From Sides of Units D4 - Units Side to Side

*Minimum D3 dimension for Condenser and Coolers Furnished with Pumps. For Units without pumps use D3 dimensions for towers.

NOTES: EVAPCO's minimum clearances guarantee proper thermal performance but further clearances may be required for proper access or maintenance as determined by the engineer responsible for plant/installation design. For large installations please consult your local EVAPCO sales representative. Refer to EVAPCO's Equipment Layout Manual (Bulletin 311) at www.evapco.com.au for further details or call your local EVAPCO sales representative for immediate assistance.

Design

EVAPCO units are of heavy-duty construction and designed for long and trouble-free operation. Proper equipment selection, installation and maintenance is, however, necessary to ensure full unit performance. Some of the major considerations in the application of a cooler are presented below. For additional information, contact your local EVAPCO sales representative.

Air Circulation

In reviewing the system design and unit location, it is important that proper air circulation be provided. The best location is on an unobstructed roof top or on ground level away from walls and other barriers. Care must be taken when locating towers in wells or enclosures or next to high walls. The potential for recirculation of hot, moist discharge air back into the fan intake exists. Recirculation raises the wet bulb temperature of the entering air causing the condensing pressure to rise above the design.

For these cases, a discharge hood or ductwork should be provided to raise the overall unit height even with the adjacent wall, thereby reducing the chance of recirculation. Good engineering practice dictates that the cooling towers discharge air not be directed or located close to or in the vicinity of building air intakes. Engineering assistance is available from the factory to identify potential recirculation problems and recommend solutions.

For additional information regarding layout of cooling towers, see pages 30 through 31 of this brochure.

Maintaining the Recirculated Water System

The heat rejection in a tower is accomplished by the evaporation of a portion of the recirculated spray water. As this water evaporates, it leaves behind all of its mineral content and impurities. Therefore, it is important to bleed-off an amount of water equal to that which is evaporated to prevent the build-up of these impurities. If this is not done, the mineral or the acidic nature of the water will continue to increase. This will ultimately result in heavy scaling or corrosive conditions.

Bleed-off

Each unit supplied with a pump mounted on the side is furnished with a clear bleed line for visual inspection and a valve which, when fully open, will bleed-off the correct amount of water. If the make-up water supplying the unit is relatively free of impurities, it may be possible to cut back the bleed, but the unit must be checked frequently to make sure scale is not forming. Make-up water pressure should be maintained between 135 and 345 kPa.

Water Treatment

A proper water treatment program is an essential part of routine maintenance in order to help assure proper operation and longevity of the unit. To help prevent the formation of "white rust", the interior of the unit should be passivated during start-up and monitored periodically as part of the water treatment program. For more information about white rust, please request a copy of EVAPCO Engineering Bulletin 36. A qualified water treatment company should be contacted to design a water treatment protocol specifically based on applicable location, water quality and unit materials of construction.

If acid is used for treatment, it should be accurately metered and the concentration properly controlled. **The pH of the water should be maintained between 6.5 and 8.0. Units constructed of galvanised steel operating with circulating water having a pH of 8.3 or higher will require periodic passivation of the galvanised steel to prevent the formation of "white rust".** Batch chemical feeding is not recommended because it does not afford the proper degree of control. If acid cleaning is required, extreme caution must be exercised and only inhibited acids recommended for use with galvanised construction should be used.

NOTE: Operating the tower below 6.0 pH for any period of time may cause the removal of the protective zinc coating on the galvanised steel components.

For more information see EVAPCO Bulletin entitled "Operation and Maintenance Instructions Bulletin 116D-Metric".

Control of Biological Contaminants

Water quality should be checked regularly for biological contamination, if biological contamination is detected, a more aggressive water treatment and mechanical cleaning program should be undertaken. The water treatment program should be performed in conjunction with a qualified water treatment company. It is important that all internal surfaces be kept clean of accumulated dirt and sludge. In addition, the drift eliminators should be maintained in good operating condition.

MECHANICAL SPECIFICATIONS

General

Factory assembled, induced draft counterflow cooling towers complete with fan, fill, louvers, accessories and lifting devices having design and materials of construction as per the following.

Construction

Basin Section

Cold water basin and basin feet shall be constructed of LTRM fibreglass with uniform thickness. All fibreglass panels shall be perfectly smooth on both faces and each surface is to be protected by UV inhibited gelcoat. Internal and external hardware shall be type 316 stainless steel.

Basins standard accessories shall include make-up valve with float ball, quick fill connection, drain, overflow and an antivortex strainer.

Casing Section

All casing panels shall be constructed of LTRM fibreglass of uniform thickness and each surface is to be protected by UV inhibited gelcoat. Internal wetted steel parts within the casing shall be type 316 stainless steel. All internal and external hardware in the casing to be type 316 stainless steel.

The casing panels shall totally encase the complete fill section to protect the fill from direct sunlight exposure. **Compliant with AS 3666 Clause 4.6 Sunlight.**

Fan Section

All fan section panels shall be constructed of LTRM fibreglass, with uniform thickness. Each surface is to be protected by UV inhibited gelcoat. Drive mechanical support shall be welded, heavy-duty type structural steel, hot dip galvanised after fabrication (HDGAF). Fan screen and mechanical hardware shall also be galvanised.

Fan

Fans having diameter 1000mm or less shall be high efficiency axial propeller type, using a high strength die cast aluminium hub and fibreglass reinforced polypropylene (FRP) wide chord blades. Each fan shall be statically balanced and installed in a closely fitted cowl with venturi air inlet for maximum fan efficiency.

Fans having diameter greater than 1000mm shall be high efficiency axial propeller type with aluminium wide chord blade construction.

Each fan shall be statically balanced and installed in a closely fitted cowl with venturi air inlet for maximum fan efficiency.

Fans designed for Super Low Sound shall be high efficiency axial propeller type with FRP hub and blade construction. Fans shall have forward sweeping blades for superior sound quality. Fans shall be statically balanced and installed in a closely fitted cowl with venturi air inlet for maximum fan efficiency.

Drift Eliminators

The eliminators shall be constructed entirely of Polyvinyl Chloride (PVC) in easily handled sections. Design shall incorporate three changes in air direction and limit the water carryover to a maximum of 0.001% of the recirculating water rate. **Compliant with AS 3666 Clause 4.4 Drift Control.**

Water Distribution System

Pressurized, non-corrosive system consisting of polyvinyl chloride (PVC) spray branches and EvapJet™ nozzles constructed from precision moulded ABS. Nozzle design includes large orifice and anti-sludge ring to eliminate clogging. Removable spray branches have threaded end caps to assist with cleaning and debris removal. Maximum 55 °C continuous spray water operating temperature.

Fill

The fill shall be constructed entirely of polyvinyl chloride (PVC) in easily handled sections. PVC sheets are chemically bonded together for strength & durability and spaced 12 mm apart. Fill is self-extinguishing for fire resistance, has a flame spread of 5 under ASTM designation E-84-81a, and is resistant to rot, decay, and biological attack.

Air Inlet Louvers

The Air Inlet Louvers shall be constructed from UV inhibited polyvinyl chloride (PVC) and is set within a SS316 frame that allows for easy removal of louvers for access to the entire basin area for maintenance. The louvers shall have a minimum of two changes in air direction and shall be of a non-planar design to prevent splash out, block direct sunlight and debris from entering the basin. **Compliant with AS 3666 Clause 4.6 Sunlight.** Air Inlet Louvers shall be manufactured by the cooling tower supplier to ensure single source responsibility and control of the final product.

Make-up Float Valve Assembly

Make-up Float Valve Assembly shall be brass float valve with stainless steel arm and adjustable plastic float.

Access

Casing Access: A removable full casing height access door shall be provided to facilitate maintenance or removal of fill, drift eliminators and the water distribution system.

Basin Access: Framed removable louver panels shall be on four (4) sides of the unit for basin access.

Basin Strainer

Basin Strainer shall be all type 316 stainless steel construction with large area removable perforated screens.

Fan Motor

Fan motor(s) shall be totally enclosed, ball bearing type electric motor(s) with IP56 protection rating suitable for moist air service. Motor(s) shall be MEPS 2006 compliant with epoxy coated finish.

Belt Drive Fans

Fans having diameter greater than 1000mm shall be belt driven by multi-groove, solid back V-belt type with taper lock bushings designed for 150% of the motor nameplate power. The belt material shall be neoprene reinforced with polyester chord and specifically designed for cooling equipment service. Fan pulley shall be aluminium alloy construction. Belt adjustment shall be accomplished from the exterior of the unit.

Fan bearings shall be heavy duty, self-aligning, pillow block type with extended lubrication lines and fittings. Minimum L10 life for bearings shall be 75,000 hours.

Fan shaft shall be constructed from solid type polished steel.

Sound

The maximum sound pressure levels (dB) including water noise with all fans operating at full speed shall be measured and presented in accordance with CTI ATC-128.

Thermal Performance & Certification

The cooling towers, inclusive of all accessories and sound reduction options, shall be certified by the Cooling Technology Institute (CTI) under standard 201RS (STD-201RS). Published thermal performance tables and detailed certification information for the specific model number shall be available on CTI's public website (<https://www.cti.org>).

Understanding & Specifying Sound

Sound

Sound is the alteration in pressure, stress, particle displacement and particle velocity, which is propagated in an elastic material. Audible sound is the sensation produced at the ear by very small pressure fluctuations in the air.

Sound Pressure

Sound pressure is the intensity of sound. Sound pressure (L_p) in decibels is the ratio of measured pressure (P) in the air to a reference sound pressure, $P_0=2 \times 10^{-5}$ Pascal based on the following formula:

$$L_p(\text{dB}) = 10 \log_{10} (\Delta P^2 / \Delta P_0^2)$$

Sound pressure level is what is actually being measured when sound data is recorded. Microphones that measure sound are pressure-sensitive devices that are calibrated to convert the sound pressure waves into decibels. Similar to the intensity coming from a light bulb which gets dimmer as one gets further and further away, sound pressure decreases in decibel as your ear gets further from the sound source.

Sound Power

Sound power is the energy of sound. Sound power (L_w) in decibels is the ratio of the calculated sound power, (W) to a reference power, $W_0=1$ picowatt, according to the following formula:

$$L_w(\text{dB}) = 10 \log_{10} (W/W_0)$$

Sound power level is not a measured value, but is calculated based on the measured sound pressure. Similar to wattage of a light bulb that does not change the farther one is away from the light bulb, sound power does not vary with distance.

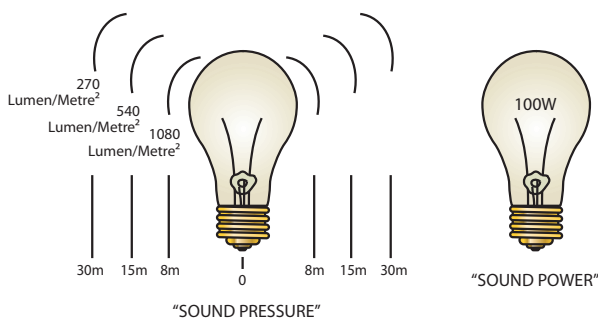

Adding Multiple Sound Sources

Since the decibel is a logarithmic function, the numbers are not added linearly. Therefore, two 73 dB sound sources added together do not equal 146 dB. The resultant sound would actually be 76 dB. The following table shows how to add decibels from two sound sources:

Difference in dB Level	Add to the higher dB Level
0 to 1	3
2 to 3	2
4 to 8	1
9 or greater	0

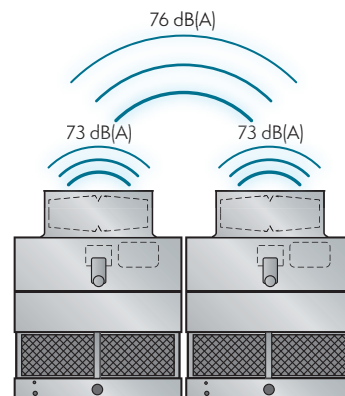

Sound Pressure – The A-Weighted Scale

The A-Weighted Scale, dB(A) is a means to translate what a sound microphone measures to how the human ear perceives the sound. Use the following formula and conversions:

$$sB(A) = 10 \log_{10} \sum 10^{((dB+C_f)/10)}$$

$f=800$
 $f=63$

where: C_f =correction factor per band let: $Z_f=(dB+C_f)/10$
 dB = measured sound pressure

Band	Center Frequency	Frequency (Hz)	Sample Range (Hz)	C_f (Hz)	Z_f (dB)
1	63	44-88	68	-26.2	4.18
2	125	89-175	76	-16.1	5.99
3	250	176-350	77	-8.6	6.84
4	500	351-700	73	-3.2	6.98
5	1000	701-1400	70	0	7.00
6	2000	1401-2800	68	+1.2	6.92
7	4000	2801-5600	71	+1.0	7.20
8	8000	5601-11200	73	-1.1	7.19

Example calculation of the dB(A) formula using the sample data.

$$dB(A) = 10 \log_{10} \sum 10^{(z_1)} + 10^{(z_2)} + 10^{(z_3)} + 10^{(z_4)} + 10^{(z_5)} + 10^{(z_6)} + 10^{(z_7)} + 10^{(z_8)} = 10 \log_{10}(67114245.2) = 78.3dB(A)$$

THE SCIENCE OF SOUND

Specifying Sound

Specifying sound pressure in dB(A) measured 1.5 metres above the fan discharge during full speed operation.

- All manufacturers can meet a performance specification with low sound options.
- Fan noise is what matters. 1.5 metres above the fan is where it matters.

Measurement Location

Per Cooling Technology Institute Standard ATC-128

A sound microphone should be located 1.5 metres above the cooling tower fan cowl edge at a 45° angle. This position assures accurate sound measurements and eliminates a source of uncertainty by taking the microphone out of the high velocity fan discharge air.

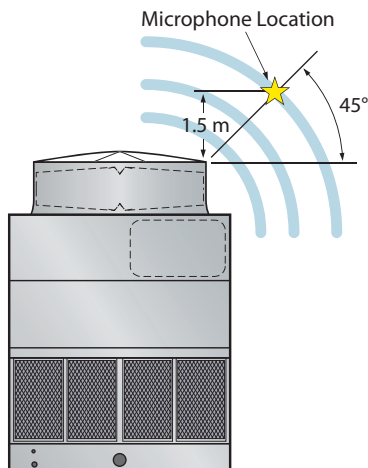

Typical Sound Pressure Levels of Well Known Noises:

Jet Airplane, 45 metres away	140 dB(A)
Circular Saw	110 dB(A)
Nightclub	100 dB(A)
Semi Truck	90 dB(A)
Sidewalk of a Busy Road	80 dB(A)
Household Vacuum, 1 metre away	70 dB(A)
Normal Conversation	60 dB(A)
Quiet Library	40 dB(A)

Notable Facts about Sound:

- +/-1dB(A) is inaudible to the human ear
- Decreasing a noise source by 10 dB(A) sounds half as loud to the human ear

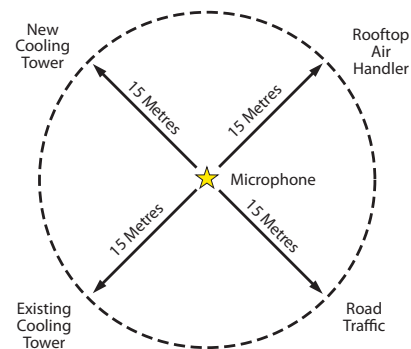

Easy Verification

At 1.5 metres from the cooling tower, a sound meter records only cooling tower noise. You can easily verify the actual noise coming from the cooling tower against the specified sound data with good certainty.

If sound were specified at 15 metres or some greater distance from the sound-sensitive location, there is increased uncertainty in the measured data due to other possible sound sources within the 15 metres radius of the sound microphone.

Sound Quality

Sound coming from the top of the cooling tower is comprised of low and mid-frequency fan noise. Low and mid-frequency fan "rumble" is very difficult to attenuate. Fan rumble travels through everything and around everything and is what is audible at any sound-sensitive location.

Sound coming from the sides of the cooling tower is comprised of high-frequency water noise which is much less objectionable than fan noise and attenuates naturally with distance.

Sound measured at the side of a cooling tower is inside the acoustical shadow of the noise emitted from the top. Outside the acoustical shadow, the low and mid-frequency fan noise completely masks the high-frequency water noise.

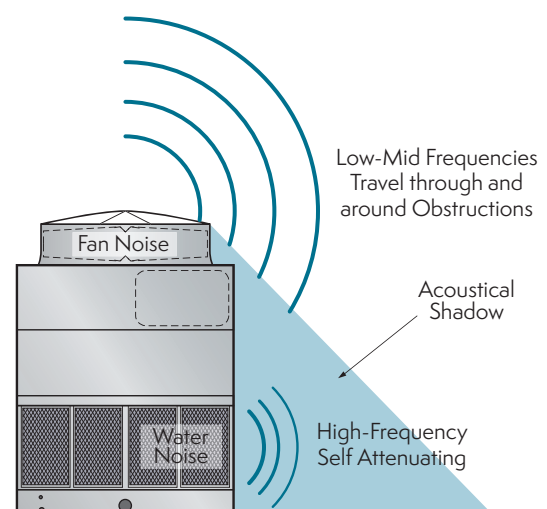

Sound Performance of Cooling Towers

Suggested Specifications

Sound Performance

Cooling tower sound performance shall be provided in pressure dB(A) measured 1.5 metres above the fan discharge during full speed fan operation with water running in accordance with CTI acceptance test code 128 (ATC-128).

Super Low Sound Axial Propeller Fans

Units shall be provided with Super Low Sound Fans in order to assure a maximum sound pressure level not to exceed _____ dB(A) measured 1.5m away from the fan discharge cylinder during full speed fan operation with water running in accordance with CTI ATC-128.

Fans shall be high efficiency axial propeller type with non-corrosive FRP hub and blade construction. The heavy duty fan construction shall utilise a forward swept blade design for superior sound quality. Each fan shall be statically balanced and installed in a closely fitted cowl with venturi air inlet for maximum fan efficiency.

Low Sound Axial Propeller Fans

Units shall be provided with Low Sound Fans in order to assure a maximum sound pressure level not to exceed _____ dB(A) measured 1.5m above the fan discharge cylinder during full speed fan operation with water running in accordance with CTI ATC-128.

Fans shall be high efficiency axial propeller type with aluminium wide chord blade construction. The Low Sound Fan shall utilise a unique soft-connect blade-to-hub design that is compatible with Variable Speed Drives. Each fan shall be statically balanced and installed in a closely fitted cowl with venturi air inlet for maximum fan efficiency.

Water Silencers

The unit shall be provided with water silencers located in the falling water area of the cold water basin. The water silencers shall be constructed of lightweight PVC in easily handled sections for ease of removal and access to the basin area.

Technical Support Services

Equipment Selection Software

SPECTRUM™ by EVAPCO is a new industry leading computer selection program that makes it easy for you to find and optimise the right EVAPCO solutions for every project. Evaluate thermal performance, layout, and energy requirements across units; analyse optional equipment features; and generate complete specifications and unit drawings – all within a friendly and intuitive format. Contact your EVAPCO sales representative to access SPECTRUM™ now.



Public Website

Visit www.evapco.com.au for a complete list of EVAPCO Australia's product offerings. The most current Catalogues, Rigging and Assembly Manuals, Operation and Maintenance Manuals can be downloaded from the website.

- Product Literature
- Catalogues
- Rigging Instructions
- Operation and Maintenance Manuals
- Videos

Drawings of Cooling Towers, Closed Circuit Coolers and Condensers are provided via this link: www.evapco.com.au/resources

The following drawings are provided:

- Unit Certified Drawings (.pdf format)
- Pier Support Drawings (.pdf format)
- Scaled isometric views of towers in CAD (.dwg format)

MATERIAL SPECIFICATION



EVAPCO MTT QUICK REFERENCE MATERIAL SPECIFICATION CHART		
SUMMARY	STANDARD	OPTION 3 - All 316
Steel Parts - Dry Section	HDGAF	316SST
Steel Parts - Wet Section	316SST	
Unit Structure		
Casing & Access Door	LRTM Composite Fibreglass	
Corner Support Structure		
Fan Deck & Fan Cylinder		
Cold Water Basin/Sump		
Heat Transfer Section - Wet		
Drift Eliminators*	PVC	
Drift Eliminator Supports	316SST	
Fill Media*	PVC	
Fill Supports	316SST	
Inlet Louver Material	PVC	
Inlet Louver Frames	316SST	
Mechanical Equipment - Dry		
Mechanical Support Frame	HDGAF, Welded	316SST, Welded
Fan and Drive Guard Screens	HDGAF	316SST
Drive Guard Body	LRTM	
Std Fan Blades - Hub (DD Models)	PPG - Aluminium	
Std Fan Blades - Hub (BD Models)	Alum - Anodised Steel	
Fan Shaft (BD Models)	Solid Carbon Steel	Solid 316SST
Fan Shaft Bearings	Heavy Series, Square Flanged (cast iron) with Self Locking Collars, minimum L10 life 75,000 hrs	
Drive - Belt (BD Models)	Solid-back Multi-Groove Power Band Sized for 150% Motor Power	
Fan Motor	Epoxy Coated IP56 MEPS2-2006 Compliant ⁽¹⁾	
Fan Motor Shaft	Mild Steel	
External Service Platform with Ladder/Cage (optional accessory)		
Platform	FRP	
Platform Supports	HDGAF	
Ladder/Cage	HDGAF	
Water Distribution System - Wet		
Spray Branches ^Δ	PVC	
Spray Branch Supports	316SST	
Nozzles	EvapJet, ABS Plastic, with 25mm diameter non-clog orifice	
Make Up Valve Assembly		
Make Up Valve	Brass	
Float Arm Assembly	316SST	
Float Ball / Pancake	Plastic	
Connections		
Inlet / Outlet ⁽²⁾	PVC - Table E Flange AS2129	
Balance Line - Optional ⁽²⁾	PVC - Table E Flange AS2129	
Make Up and Quickfill	316SST - MPT	
Overflow & Drain	PP Schedule 80 - FPT	
Suction Strainer	316SST	
Fasteners / Hardware		
Panel-to-Panel Joints	316SST	
Panel-to-SST Joints	316SST	
Panel-to-HDGAF Joints	GALV	-
Warranty		
Motor and Drive System ⁽³⁾	5 years	
Comprehensive Unit Warranty ⁽³⁾	1 year	5 years
Notes		
PPG - Glass Reinforced Polypropylene PP - Polypropylene LRTM - Light Resin Transfer Moulded Composite Fibreglass BD - Belt Drive Models DD - Direct Drive Models		
HDGAF - Hot Dip Galvanised After Fabrication GAL Z700 - Mill Galvanised Steel 700g/m2 GALV - Zinc Protected Hardware		
* Standard material provided is PVC unless optional HPVC Fill and/or HPVC Drift Eliminators is otherwise indicated on the Technical Data Sheet.		
Δ Standard material provided is PVC unless Technical Data Sheet indicates Water Distribution Piping CPVC is included.		
(1) Standard offer motor is MEPS2-2006 compliant as per AS1359.5, Section 2, Clause 2.3, Table B2.		
(2) Other flange types upon special request.		
(3) Refer to warranty statement for complete details and conditions of warranty.		



for LIFE

EVAPCO PRODUCTS ARE MANUFACTURED WORLDWIDE.



World Headquarters/ Research and Development Center

EVAPCO Facilities

EVAPCO Australia Pty Ltd - Continental Headquarters for Australia, New Zealand, and Oceania

EVAPCO Australia Pty Ltd, 34-42 Melbourne Road, Riverstone NSW 2765, Australia
Phone: +61 2 9627 3322 • Email: sales@evapco.com.au • Website: www.evapco.com.au

EVAPCO North America

EVAPCO, Inc. World Headquarters
P.O. Box 1300 Westminister, MD 21158 USA
Phone: +1 410-756-2600
Fax: +1 410-756-6450
E-mail: marketing@evapco.com

EVAPCO East
5151 Allendale Lane Taneytown, MD 21787 USA
Phone: +1 410-756-2600
Fax: +1 410-756-6450
E-mail: marketing@evapco.com

EVAPCO Midwest
1723 York Road Greenup, IL 62428 USA
Phone: +1 217-923-3431
Fax: +1 217-923-3300
E-mail: evapcomw@evapcomw.com

EVAPCO West
1900 West Almond Avenue Madera, CA 93637 USA
Phone: +1 559-673-2207
Fax: +1 559-673-2378
E-mail: contact@evapcowest.com

EVAPCO Iowa
925 Quality Drive Lake View, IA 51450 USA
Phone: +1 712-657-3223
Fax: +1 712-657-3226

EVAPCO Iowa Sales & Engineering
215 1st Street, NE P.O. Box 88 Medford, MN 55049 USA
Phone: +1 507-446-8005
Fax: +1 507-446-8239
E-mail: evapcomn@evapcomn.com

EVAPCO Newton
701 East Jourdan Street Newton, IL 62448 USA
Phone: +1 618-783-3433
Fax: +1 618-783-3499
E-mail: evapcomw@evapcomw.com

EVAPCOLD
521 Evapco Drive Greenup, IL 62428 USA
Phone: +1 217-923-3431
E-mail: evapcomw@evapcomw.com

EVAPCO-BLCT Dry Cooling, Inc.
1011 US Highway 22 West Bridgewater, New Jersey 08807 USA
Phone: +908-379-2665
E-mail: info@evapco-blct.com

Refrigeration Valves & Systems Corporation
A wholly owned subsidiary of EVAPCO, Inc.
1520 Crosswind Dr. Bryan, TX 77808 USA
Phone: +1 979-778-0095
Fax: +1 979-778-0030
E-mail: rvs@rvscorp.com

EvapTech, Inc.
A wholly owned subsidiary of EVAPCO, Inc.
8331 Nieman Road Lenexa, KS 66214 USA
Phone: +1 913-322-5165
Fax: +1 913-322-5166
E-mail: marketing@evaptech.com

Tower Components, Inc.
A wholly owned subsidiary of EVAPCO, Inc.
5960 US HWY 64E Ramseur, NC 27316
Phone: +1 336-824-2102
Fax: +1 336-824-2190
E-mail: mail@towercomponentsinc.com

EVAPCO South America

Evapco Brasil
Equipamentos Industriais Ltda.
Al. Vênus, 151 - CEP: 13347-659 Indaítuba - Sau Paulo - Brasil
Phone: +55 11-5681-2000
E-mail: vendas@evapco.com.br

EVAPCO Europe

EVAPCO Europe BVBA European Headquarters
Heersteveldweg 19 Industrieterrein Oost 3700 Tongeren, Belgium
Phone: +32 1-239-5029
Fax: +32 1-223-8527
E-mail: evapco.europe@evapco.be

EVAPCO Europe, S.r.l.
Via Ciro Menotti 10 I-20017 Passirana di Rho, Milan, Italy
Phone: +39 02-939-9041
Fax: +39 02-935-00840
E-mail: evapcoeuropa@evapco.it

EVAPCO Europe, S.r.l.
Via Dosso 2 23020 Piateda Sondrio, Italy

EVAPCO Europe GmbH
Insterburger Straße 18 D-40670 Meerbusch, Germany
Phone: +49 2159-695618
Fax: +49 2159-695611
E-mail: info@evapco.de

EVAPCO Air Solutions
Knosgårdvej 115 DK-9440 Aabybro Denmark
Phone: +45 98-244-999
Fax: +45 98-244-990
E-mail: info@flexcoil.dk

EVAPCO Air Solutions GmbH
Berenbosteler Str. 76 A 30823 Garbsen, Germany
Phone: +49 5137 93875-0 / +49 5137 93875-20
E-mail: info@evapcoas.de

Evap Egypt Engineering Industries Co.
A licensed manufacturer of EVAPCO, Inc.
5 El Nasr Road Nasr City, Cairo, Egypt
Phone: +2 02-2402-2866 / +2 02 2404-4997
Fax: +2 02-2404-4668-7 / +2 02-2404-4668
E-mail: Primacool@link.net / Shady@primacool.net

EVAPCO S.A. (Pty.) Ltd.
A licensed manufacturer of EVAPCO, Inc.
18 Quality Road, Isando 1600 Republic of South Africa
Phone: +27 11-392-6630
Fax: +27 11-392-6615
E-mail: evapco@evapco.co.za

EVAPCO Asia/Pacific

EVAPCO Asia/Pacific Headquarters
1159 Luoning Rd. Baoshan Industrial Zone Shanghai, 200949, P. R. China
Phone: +86 21-6687-7786
Fax: +86 21-6687-7008
E-mail: marketing@evapcochina.com

EVAPCO (Shanghai) Refrigeration Equipment Co., Ltd.
1159 Luoning Rd., Baoshan Industrial Zone Shanghai 200949, P.R. China
Phone: +86 21-6687-7786
Fax: +86 21-6687-7008
E-mail: marketing@evapcochina.com

Beijing EVAPCO Refrigeration Equipment Co., Ltd.
No.13 Yanxi Avenue, Yanqi Development Zone Huai Rou Country Beijing, P.R. China 101407
Phone: +86 10-6166-7238
Fax: +86 10-6166-7395
E-mail: evapcoobj@ecapcochina.com

EVAPCO Australia (Pty.) Ltd.
34-42 Melbourne Road P.O. Box 436 Riverstone, N.S.W. 2765, Australia
Phone: +61 2-9627-3322
Fax: +61 2-9627-1715
E-mail: sales@evapco.com.au

EVAPCO Composites Sdn. Bhd
No. 70 (Lot 1289) Jalan Industri 2/3 Rawang Integrated Industrial Park 48000 Rawang, Selangor, Malaysia
Phone: +60 3-6092-2209
Fax: +60 3-6092-2210

EvapTech Asia Pacific Sdn. Bhd
A wholly owned subsidiary of EvapTech, Inc.
B-6-1, IOI Boulevard Jalan Kenari 5, Bandar Puchong Jaya 47170 Puchong, Selangor, Malaysia
Phone: +60 3-8070-7255
Fax: +60 3-8070-5731
E-mail: marketing-ap@evaptech.com



EVAPCO...LOW ENERGY, LOW SOUND, LOW RISK

Visit EVAPCO's Website at: www.evapco.com.au

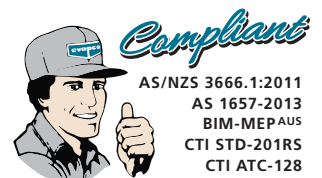

AS/NZS 3666.1:2011
AS 1657-2013
BIM-MEP AUS
CTI STD-201RS
CTI ATC-128