

# EQUIPMENT LAYOUT MANUAL

For Cooling Towers, Evaporative Condensers & Closed Circuit Coolers





## Table of Contents

**Introduction** ..... 2

**Induced Draft Counterflow Unit Layout**

Single Units ..... 3

Single/Multiple Unit Installations ..... 4

Large Installations ..... 6

Special Enclosures ..... 6

Expansions to Existing Units ..... 7

**Induced Draft Crossflow Unit Layout**

Single Units ..... 8

Multiple Units/Large Installations ..... 9

Special Enclosures ..... 10

Expansions to Existing Systems ..... 11

**Forced Draft Layout**

Single Units ..... 12

Multiple Units/Large Installations ..... 14

Special Enclosures ..... 16

Indoor Installations ..... 17

Expansions to Existing Systems ..... 18

**Other Layout Criteria**

Space Requirements for Maintenance ..... 19

Space Requirements for Unit Piping ..... 19

## Introduction

The location of evaporative cooling equipment is an important consideration when reviewing system design. Since evaporative cooling equipment requires large quantities of air, adequate spacing around the unit must be provided for it to perform properly. An equally important consideration when laying out the equipment is to locate the unit so that recirculation is minimized.

This technical manual has been written by EVAPCO engineers to provide recommended layout criteria for EVAPCO induced draft and forced draft equipment installations. Although it deals primarily with the layout of cooling towers, the principles presented apply to EVAPCO evaporative condensers and closed circuit coolers as well.

### Recirculation

Recirculation occurs when some of the hot, moist discharge air leaving the cooling tower flows back into the fresh air inlets of the unit. The heat-laden discharge air leaving the cooling tower is saturated and can be at a 5.6°-8.4°C higher wet bulb temperature than the ambient wet bulb. Therefore, any amount of recirculation will increase the wet bulb temperature of the air entering the unit. The available tonnage of the unit is decreased when the entering air wet bulb temperature is increased. For example, if the inlet wet bulb temperature is increased from 25.6° to 26.7°C, capacity is reduced by approximately 16%, corresponding to an increase in leaving water temperature of approximately 1.1°C. As can be seen from this example, a small increase in the entering air wet bulb temperature has a dramatic affect on the unit's performance. In extreme cases where the entering wet bulb temperature is increased by 2.8° to 3.3°C, the available tonnage of the unit is reduced by more than 50%.

### Equipment Layout Planning

Proper equipment layout is essential to ensure that the cooling tower will operate at its rated capacity. The objective is for the evaporative cooling equipment to be located so that fresh air is allowed to enter the unit freely, to ensure that recirculation is minimized. The first step in achieving this goal is to consider the many factors that may affect the cooling tower installation. During the design of the system, special attention needs to be given to space limitations, surrounding structures, existing units, proximity of neighbors, prevailing winds, piping, and any possible future expansion plans. Once this information is obtained, the guidelines contained in this bulletin can be used to determine the best layout for the equipment.

The layout criteria presented in the manual are based on years of successful experience with evaporative cooling installations. Following these guidelines will provide the best equipment layout which will ensure proper air flow to the unit, minimize recirculation, and allow adequate space for maintenance.

### Minimizing Legionella

Proper positioning of the cooling tower, as well as a regular maintenance program are essential to minimize the potential for growth of Legionella bacteria in the cooling tower. The cooling tower should be located away from fresh air intakes, operable windows, kitchen exhaust, and prevailing winds directed toward public areas. The cooling tower should have a water treatment program, and must be thoroughly cleaned on a regular basis. If the cooling tower is to be idle for extended periods, it should be drained. If draining is not practical, a system shock with a biocide is required prior to running the fans.

# Induced Draft Counterflow Unit Layout

## Single Unit Installations

The best place to locate any cooling tower is on a roof by itself. However, when this is not possible, correct layout guidelines must be followed to provide a satisfactory installation.

The first item to consider is the position of the unit with respect to other structures. The top of the cooling tower must be equal to or higher than any adjacent walls, buildings or other structures. When the top of the unit is lower than the surrounding structures (Figure 1 & 2), recirculation can be a major problem. If the unit is on the windward side, as shown in Figure 1, the discharge air will be forced against the building and then spread in all directions, including downward, toward the air inlets.

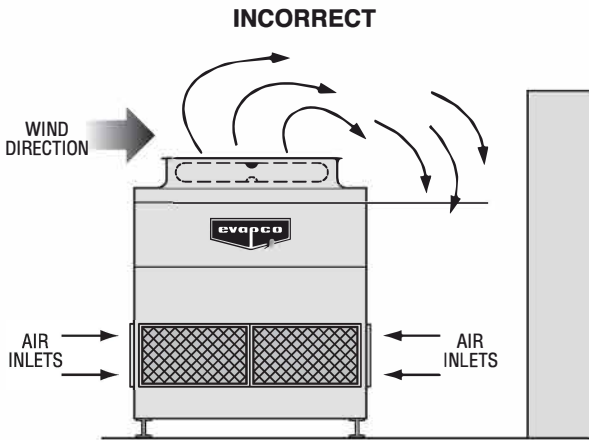

Figure 1 - Installation with Top of Unit Lower than Top of Wall

When the wind comes from the opposite direction, the resulting negative pressure area created by the wind passing over the building will cause the discharge air to be forced back into the inlets, as shown in Figure 2. Even if neither of these conditions occurs, the presence of much taller structures can potentially inhibit the dissipation of the hot moist discharge air.

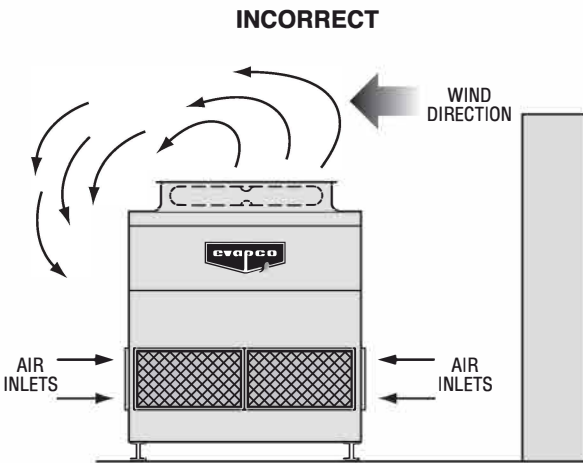

Figure 2 - Wind Effect with Top of Unit Lower than Top of Wall

The conditions shown in Figures 1 & 2 can be corrected by elevating the unit on structural steel so that the top of the fan cowl is equal to or higher than the adjacent structures, as shown in Figure 3. Fan cowl extensions can also be provided to elevate the fan discharge of the cooling tower to the proper height, as shown in Figure 4. **For installations where neither of these options are possible, an experienced engineering decision must be made regarding the potential of a performance impact.**

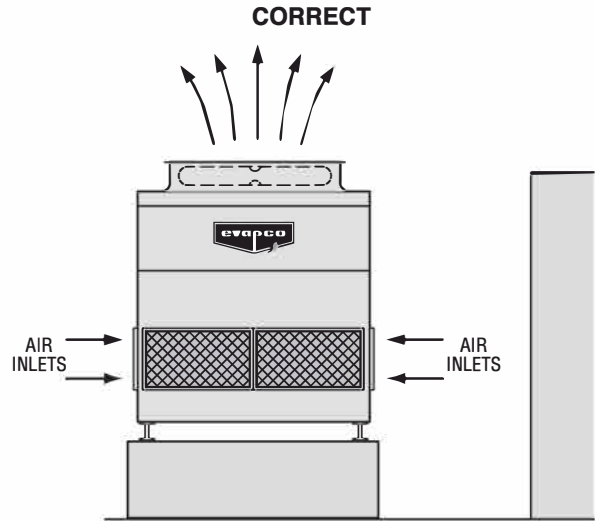

Figure 3 - Installation Elevated so Top of Unit Is Higher than Top of Wall

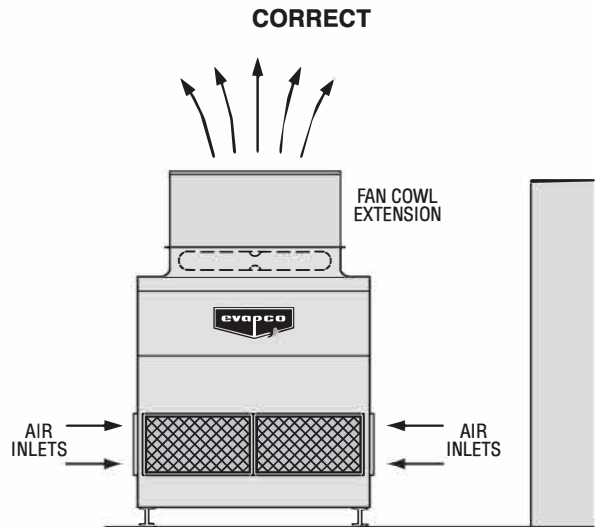

Figure 4 - Fan Discharge Elevated so Top of Unit Is Higher than Top of Wall

NOTE: Fan cowl extensions require external support, supplied by other for: Fan cowls over 1.24m from the fan deck for 2.5m wide units and smaller, and fan cowls 1.3m from the fan deck for 3m wide and larger units.

## Single/Multiple Unit Installations

EVAPCO's induced draft, counterflow units may have air inlets located on all four sides. When the unit is located near a wall or other structure that blocks fresh air from entering the unit, consideration must be given to the clearance distance between the air inlets of the unit and this blockage. In this type of layout, air will be drawn in through the space between the unit and the wall or other structure as well as down from above. It is important to provide adequate space in front of each air inlet to ensure proper air flow and prevent air recirculation.

When more than one EVAPCO induced draft counterflow units are installed at the same location, the potential for recirculation becomes a greater concern. For installations with two or more cooling towers, the units may be placed in a variety of locations depending on site conditions and available space.

EVAPCO has developed the recommended distances for various cases of induced draft counterflow layouts. These distances have been developed to ensure that the units are provided with adequate airflow and that recirculation is minimized. Space must also be provided for piping, accessories, removal of access panels and for maintenance of the mechanical equipment.

Product improvements confirmed by factory testing and years of field experience have allowed EVAPCO to develop minimum required distances from the unit and the surrounding walls as well as between units†. In addition, the distances shown in the following tables are dependent on the number of surrounding walls and the number of units. Therefore, the data presented in Tables 1 and 2 show the minimum dimensions  $D_1$  through  $D_8$  required for a variety of installation cases. See the following figures that illustrate these various cases.

For layouts of multiple multi-cell units similar to Figures 16 and 18, please contact the factory for confirmation of layout design (see page 6).

### CASE 1 - Single Wall/Single Unit

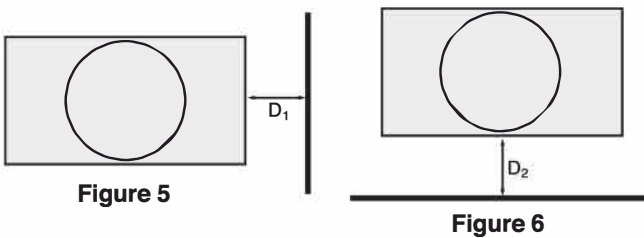

### CASE 2 - No Obstructions

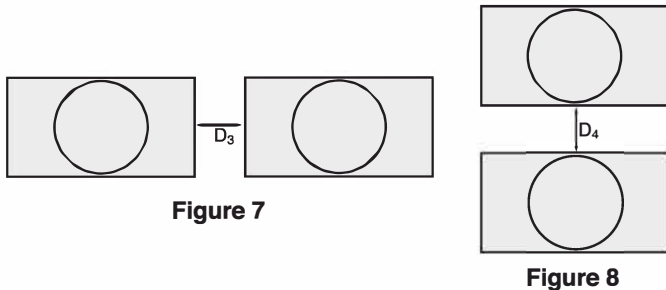

### CASE 3 - Two Walls/Single Unit

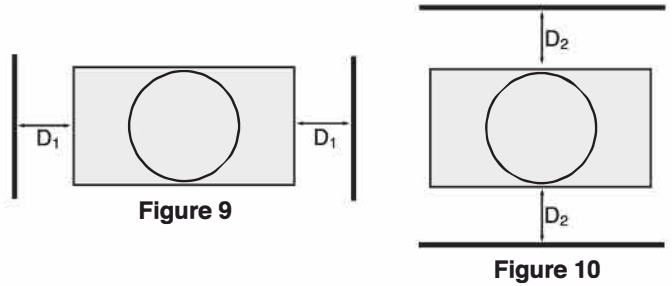

### CASE 4 - Two Walls/Two Units

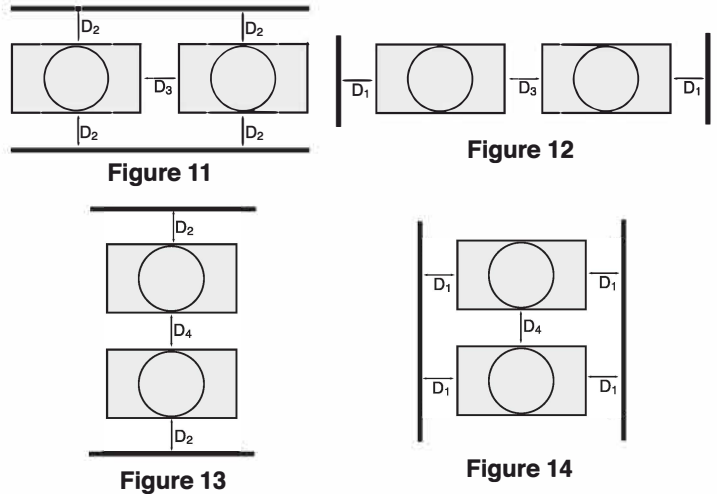

### CASE 5 - Two Walls (Corner)

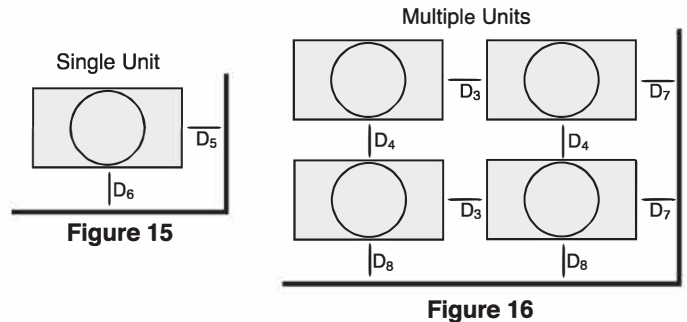

### CASE 6 - Three Walls

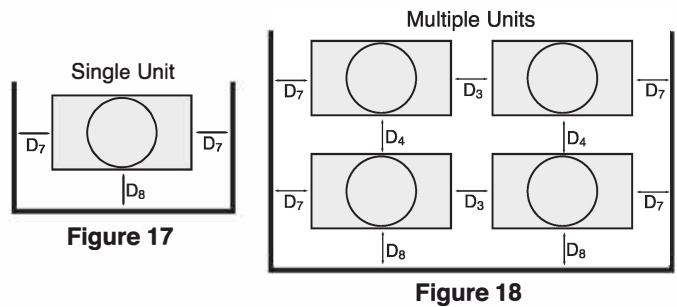

† The guidelines set forth in Tables 1 & 2 are to be used exclusively for EVAPCO equipment. Data from factory testing is based on air discharge velocities and air intake areas that are specific to EVAPCO equipment. Therefore, this data is NOT to be applied to other manufacturers' evaporative cooling equipment. However, any nearby equipment that is either intaking or discharging air will affect the overall layout. Please contact the factory with any questions on how to space around other manufacturer's equipment.

**Table 1 - Dimensions D<sub>1</sub> – D<sub>4</sub>**

**Table 2 - Dimensions D<sub>5</sub> – D<sub>8</sub>**

**0.9m and 1.2m Wide Models**

| Unit Length (m) | Minimum Dimensions (m) |                |                |                |                |
|-----------------|------------------------|----------------|----------------|----------------|----------------|
|                 | All Units              | All Units      | Towers         | Cond./Coolers* | All Units      |
|                 | D <sub>1</sub>         | D <sub>2</sub> | D <sub>3</sub> | D <sub>3</sub> | D <sub>4</sub> |
| All Units       | 0.6                    | 0.6            | 0.6            | 1.8            | 0.6            |

**1.8m to 2.5m Wide Models**

| Unit Length (m) | Minimum Dimensions (m) |                |                |                |                |
|-----------------|------------------------|----------------|----------------|----------------|----------------|
|                 | All Units              | All Units      | Towers         | Cond./Coolers* | All Units      |
|                 | D <sub>1</sub>         | D <sub>2</sub> | D <sub>3</sub> | D <sub>3</sub> | D <sub>4</sub> |
| to 8.5          | 0.9                    | 0.9            | 0.9            | 1.8            | 1.8            |
| 11.0            | 0.9                    | 1              | 0.9            | 1.8            | 1.8            |
| 12.9            | 0.9                    | 1.2            | 0.9            | 1.8            | 1.8            |

**3m and 3.6m Wide Models**

| Unit Length (m) | Minimum Dimensions (m) |                |                |                |                |
|-----------------|------------------------|----------------|----------------|----------------|----------------|
|                 | All Units              | All Units      | Towers         | Cond./Coolers* | All Units      |
|                 | D <sub>1</sub>         | D <sub>2</sub> | D <sub>3</sub> | D <sub>3</sub> | D <sub>4</sub> |
| to 8.5          | 0.9                    | 0.9            | 0.9            | 1.8            | 1.8            |
| 11.0            | 0.9                    | 1.2            | 1              | 1.8            | 2.1            |
| 12.2            | 0.9                    | 1.2            | 1              | 1.8            | 2.3            |
| 12.9            | 0.9                    | 1.2            | 1              | 1.8            | 2.4            |
| 16.5            | 0.9                    | 1.5            | 1.2            | 1.8            | 3              |
| 18.4            | 0.9                    | 1.7            | 1.2            | 1.8            | 3              |

**4.2m Wide Models**

| Unit Length (m) | Minimum Dimensions (m) |                |                |                |                |
|-----------------|------------------------|----------------|----------------|----------------|----------------|
|                 | All Units              | All Units      | Towers         | Cond./Coolers* | All Units      |
|                 | D <sub>1</sub>         | D <sub>2</sub> | D <sub>3</sub> | D <sub>3</sub> | D <sub>4</sub> |
| 7.2 & 7.8       | 0.9                    | 0.9            | 0.9            | 1.8            | 1.8            |
| 14.5 & 15.7     | 0.9                    | 1.5            | 1.2            | 1.8            | 2.7            |
| 21.8 & 23.6     | 1.2                    | 2.1            | 1.5            | 1.8            | 3.6            |

**4.6m to 5.2m Wide Models**

| Unit Length (m) | Minimum Dimensions (m) |                |                |                |                |
|-----------------|------------------------|----------------|----------------|----------------|----------------|
|                 | All Units              | All Units      | Towers         | Cond./Coolers* | All Units      |
|                 | D <sub>1</sub>         | D <sub>2</sub> | D <sub>3</sub> | D <sub>3</sub> | D <sub>4</sub> |
| All Units       | 0.9                    | 0.9            | 1.8            | 1.8            | 1.8            |

**6.1m to 7.3m Wide Models**

| Unit Length (m) | Minimum Dimensions (m) |                |                |                |                |
|-----------------|------------------------|----------------|----------------|----------------|----------------|
|                 | All Units              | All Units      | Towers         | Cond./Coolers* | All Units      |
|                 | D <sub>1</sub>         | D <sub>2</sub> | D <sub>3</sub> | D <sub>3</sub> | D <sub>4</sub> |
| to 6            | 0.9                    | 0.9            | 1.8            | 1.8            | 1.8            |
| 7.3             | 1                      | 1.2            | 2              | 2              | 2.4            |
| 8.5             | 1                      | 1.4            | 2.1            | 2.1            | 2.4            |
| 11 & 12.2       | 1.4                    | 1.8            | 2.7            | 2.7            | 3.3            |

**8.6m Wide Models**

| Unit Length (m) | Minimum Dimensions (m) |                |                |                |                |
|-----------------|------------------------|----------------|----------------|----------------|----------------|
|                 | All Units              | All Units      | Towers         | Cond./Coolers* | All Units      |
|                 | D <sub>1</sub>         | D <sub>2</sub> | D <sub>3</sub> | D <sub>3</sub> | D <sub>4</sub> |
| 7.2 & 7.8       | 1.2                    | 1.2            | 2.4            | 2.4            | 2.4            |
| 15.5 & 16.7     | 1.5                    | 1.8            | 2.7            | 2.7            | 4              |

**13m Wide Models**

| Unit Length (m) | Minimum Dimensions (m) |                |                |                |                |
|-----------------|------------------------|----------------|----------------|----------------|----------------|
|                 | All Units              | All Units      | Towers         | Cond./Coolers* | All Units      |
|                 | D <sub>1</sub>         | D <sub>2</sub> | D <sub>3</sub> | D <sub>3</sub> | D <sub>4</sub> |
| 7.8             | 5.4                    | 1.8            | 10             | N/A            | 4.3            |

**17.3m Wide Models**

| Unit Length (m) | Minimum Dimensions (m) |                |                |                |                |
|-----------------|------------------------|----------------|----------------|----------------|----------------|
|                 | All Units              | All Units      | Towers         | Cond./Coolers* | All Units      |
|                 | D <sub>1</sub>         | D <sub>2</sub> | D <sub>3</sub> | D <sub>3</sub> | D <sub>4</sub> |
| 7.8             | 5.8                    | 1.8            | 11.8           | N/A            | 4.3            |

\* Minimum D<sub>3</sub> dimension for Condensers and Coolers Furnished with Pumps. For units without pumps use D<sub>3</sub> dimension for towers.

**0.9m and 1.2m Wide Models**

| Unit Length (m) | Minimum Dimensions (m) |                |                |                |
|-----------------|------------------------|----------------|----------------|----------------|
|                 | D <sub>5</sub>         | D <sub>6</sub> | D <sub>7</sub> | D <sub>8</sub> |
|                 | All Units              | 0.6            | 0.6            | 0.6            |

**1.8m to 2.5m Wide Models**

| Unit Length (m) | Minimum Dimensions (m) |                |                |                |
|-----------------|------------------------|----------------|----------------|----------------|
|                 | D <sub>5</sub>         | D <sub>6</sub> | D <sub>7</sub> | D <sub>8</sub> |
|                 | to 5.4                 | 0.9            | 0.9            | 0.9            |
| 6.4             | 0.9                    | 0.9            | 0.9            | 1              |
| 7.3 & 8.5       | 0.9                    | 0.9            | 0.9            | 1.2            |
| 11.0            | 0.9                    | 1              | 0.9            | 1.4            |
| 12.9            | 0.9                    | 1.2            | 0.9            | 1.5            |

**3m and 3.6m Wide Models**

| Unit Length (m) | Minimum Dimensions (m) |                |                |                |
|-----------------|------------------------|----------------|----------------|----------------|
|                 | D <sub>5</sub>         | D <sub>6</sub> | D <sub>7</sub> | D <sub>8</sub> |
|                 | to 6                   | 0.9            | 0.9            | 0.9            |
| 7.3             | 0.9                    | 0.9            | 0.9            | 1              |
| 8.5             | 0.9                    | 1              | 1              | 1.2            |
| 11 & 12.2       | 0.9                    | 1.4            | 1              | 1.5            |
| 12.9            | 0.9                    | 1.5            | 1              | 1.7            |
| 16.5            | 0.9                    | 1.7            | 1              | 1.8            |
| 18.4            | 0.9                    | 1.8            | 1              | 2              |

**4.2m Wide Models**

| Unit Length (m) | Minimum Dimensions (m) |                |                |                |
|-----------------|------------------------|----------------|----------------|----------------|
|                 | D <sub>5</sub>         | D <sub>6</sub> | D <sub>7</sub> | D <sub>8</sub> |
|                 | 7.2 & 7.8              | 1              | 1.2            | 1.2            |
| 14.5 & 15.7     | 1                      | 1.8            | 1.2            | 2              |
| 21.8 & 23.6     | 1.4                    | 2.1            | 1.5            | 2.4            |

**4.6m to 5.2m Wide Models**

| Unit Length (m) | Minimum Dimensions (m) |                |                |                |
|-----------------|------------------------|----------------|----------------|----------------|
|                 | D <sub>5</sub>         | D <sub>6</sub> | D <sub>7</sub> | D <sub>8</sub> |
|                 | All Units              | 0.9            | 0.9            | 0.9            |

**6.1m to 7.3m Wide Models**

| Unit Length (m) | Minimum Dimensions (m) |                |                |                |
|-----------------|------------------------|----------------|----------------|----------------|
|                 | D <sub>5</sub>         | D <sub>6</sub> | D <sub>7</sub> | D <sub>8</sub> |
|                 | 3.6 & 4.2              | 1.2            | 0.9            | 1.4            |
| 5.4             | 1.2                    | 1              | 1.4            | 1.2            |
| 6               | 1.2                    | 1.2            | 1.4            | 1.4            |
| 7.3             | 1.4                    | 1.5            | 1.5            | 1.7            |
| 8.5             | 1.4                    | 1.7            | 1.5            | 1.8            |
| 11 & 12.2       | 1.7                    | 2.1            | 1.8            | 2.3            |

**8.6m Wide Models**

| Unit Length (m) | Minimum Dimensions (m) |                |                |                |
|-----------------|------------------------|----------------|----------------|----------------|
|                 | D <sub>5</sub>         | D <sub>6</sub> | D <sub>7</sub> | D <sub>8</sub> |
|                 | 7.2 & 7.8              | 1.5            | 1.5            | 1.7            |
| 15.5 & 16.7     | 1.8                    | 2.1            | 2              | 2.3            |

**13m Wide Models**

| Unit Length (m) | Minimum Dimensions (m) |                |                |                |
|-----------------|------------------------|----------------|----------------|----------------|
|                 | D <sub>5</sub>         | D <sub>6</sub> | D <sub>7</sub> | D <sub>8</sub> |
|                 | 7.8                    | 6.7            | 2.4            | 7.3            |

**17.3m Wide Models**

| Unit Length (m) | Minimum Dimensions (m) |                |                |                |
|-----------------|------------------------|----------------|----------------|----------------|
|                 | D <sub>5</sub>         | D <sub>6</sub> | D <sub>7</sub> | D <sub>8</sub> |
|                 | 7.8                    | 7              | 2.4            | 7.9            |

| DIMENSION KEY   |                                     |  |  |
|---|-------------------------------------|--|--|
| D <sub>1</sub> , D <sub>5</sub> & D <sub>7</sub> – From Ends of Unit  | D <sub>3</sub> – Units End to End   |  |  |
| D <sub>2</sub> , D <sub>6</sub> & D <sub>8</sub> – From Sides of Unit | D <sub>4</sub> – Units Side by Side |  |  |

**Notes:**

Special consideration is required for external service platform, see platform drawing for dimensions.  
 Special consideration is required for Smart Shield®, see Smart Shield® installation and operation manual for details.  
 For large installations please consult the factory.

## Large Installations

For large cooling tower installations that have 4 or more units, it is imperative that the unit layout be carefully examined during the design of the system.

Very large multiple unit installations can create their own environment. Under certain weather and atmospheric conditions, the large quantities of discharge air will cause the wet bulb temperature in the immediate area to be higher than the local design data. The minimum dimensions shown in Tables 1 and 2 should be increased whenever possible in order to allow for an additional safety factor. The amount of increase is dependent on the number of units, type of installation, existing equipment and unit surroundings.

The surrounding area plays an important part in the design of a large installation. Locating a large installation in a valley or between buildings will increase the chances that the discharge air will recirculate, thereby raising the entering wet bulb temperature. If it is determined that the surrounding conditions could cause recirculation, the units must be spaced properly and sized at the anticipated entering wet bulb conditions.

Another important consideration when dealing with larger multiple unit installations is prevailing winds. Although prevailing wind conditions generally change with the season, the wind direction during the hottest part of the year is of utmost importance. To minimize the potential for recirculation, it is best to locate the units so that the prevailing wind is oriented as shown in Figure 19.

Consult your local representative or EVAPCO's Marketing Department for recommended layout guidelines for very large multiple unit installations.

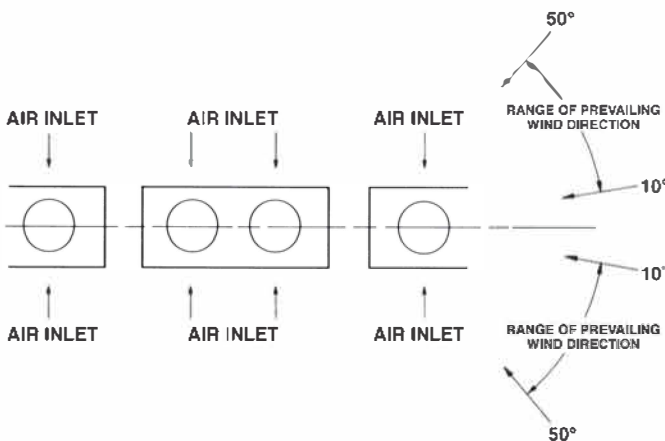

Figure 19 - Prevailing Wind

## Special Enclosures

Occasionally, induced draft counterflow units are installed in an enclosure. These installations require special consideration of the unit layout to ensure trouble free operation. Typical installations consist of units installed in solid wall or louvered enclosures or units that are located in a well.

## Solid Wall Enclosures or Wells

One typical enclosure is a unit installed in a well (Figure 20). When considering a single unit adjacent to a solid wall enclosure or located in a well, the clearance dimensions, found in Tables 1 & 2, page 5, should be used as **ABSOLUTE** minimums. **In many cases, the minimum clearance dimensions MUST be increased to ensure that the unit performs to its rated capacity.** The unit should be oriented so that the air flows uniformly to the air inlets on all four sides of the unit. The air discharge of the unit must be level with or higher than the surrounding walls. Additionally, required clearance for all unit accessories must also be taken into account.

In the well type enclosure, all the air must be brought down from above and can be susceptible to recirculation. Field experience has demonstrated that the downward velocity of the supply air into the well must be kept **BELOW 2m/s**, to avoid the effects of recirculation.

To calculate the downward velocity, the total air flow for the unit is divided by the usable well area. The usable well area (shaded portion of Figure 20) is the space between the four sides of the unit and the walls of the well. See the example shown below.

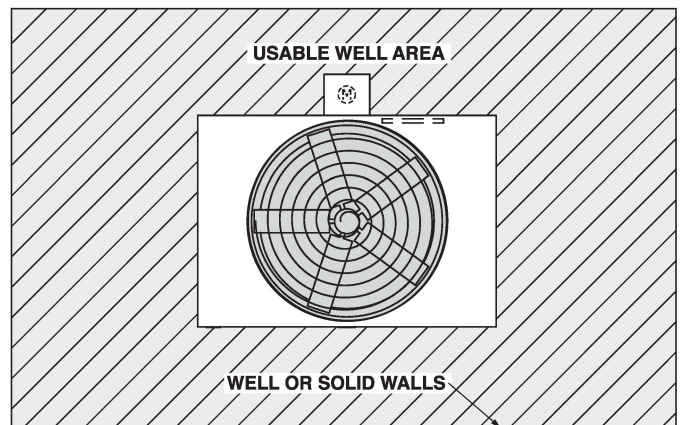

Figure 20 - Well Installation

**Example:** An AT-19-412 is centered in a 6m x 7.6m well enclosure with the unit's discharge even with the top of the surrounding walls. Is this an acceptable equipment layout?

Unit Area = 9.5m<sup>2</sup>                      D<sub>1</sub> = 2m  
 Unit = 32.6m<sup>3</sup>/s                      D<sub>2</sub> = 1.7m  
 Well Area = 6m x 7.6m = 45.6m<sup>2</sup>  
 Net Usable Well Area = 45.6m<sup>2</sup> - 9.5m<sup>2</sup> = 36.1m<sup>2</sup>  
 Downward Velocity = 32.6m<sup>3</sup>/s ÷ 36.1m<sup>2</sup> = 0.9m/s

Since the downward velocity of 0.9m/s is less than 2m/s **AND** dimensions D<sub>1</sub> and D<sub>2</sub> are above the recommended minimums, this **IS** an acceptable layout.

In some cases the well area includes space so far away from the unit as to create a point of diminishing returns.

Note: The top of the unit must be equal to, or higher than, the top of the well.

## Louvered Wall Enclosures

Induced draft counterflow units can also be installed in enclosures with louvered or slotted walls (Figure 21). With this type of enclosure, the air flow patterns will be a mixture of the open type and well installations. The inlet air will be drawn from the top and through the louvers or slotted openings.

Since the air will follow the path of least resistance, the pressure drop through the louvers will determine how much air is drawn from both areas. To minimize the potential for recirculation, it is better to draw most of the air through the louvers. Therefore, it is important that the louvers are designed for minimum pressure drop. **To achieve this goal, the velocity through the louvers should be maintained at or below 3m/s, the louvers should have a minimum of 50% net free area, and the air inlets should face the louvers.**

The first step in checking a louvered type enclosure is to treat it as a well enclosure and calculate the downward air velocity assuming that all the air must enter from the top. If the downward air velocity is equal to or less than 2m/s, then the louvered enclosure will work regardless of the size of the louvers.

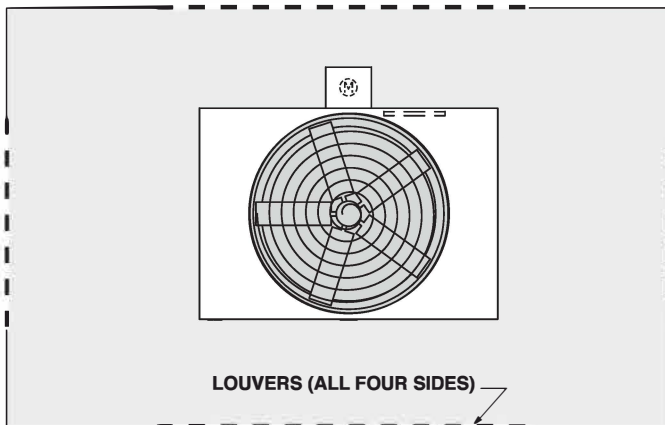

Figure 21 - Louvered Wall Enclosure

If the downward air velocity into the enclosure is greater than 2m/s, then another formula must be used. This formula, proven by years of field experience, assumes that **ALL** the air is drawn through the louvers. The total air flow for the unit is divided by the net free louver area. The resultant air velocity must be **BELOW 3m/s**. In addition to meeting this minimum louver velocity, the installation must also meet the following requirements. The minimum air inlet to louver dimension must be 0.9m and the minimum space requirements, for maintenance and unit accessories, as shown on page 19, must also be maintained.

## Expansions to Existing Systems

Expansions to existing systems present the same concerns as multiple unit installations. However, there are additional concerns that must be evaluated when planning a cooling tower expansion. Since in an expansion the new unit may not be identical to the existing one, it is important to examine the heights of the new and the existing units. Whenever possible, the tops of **ALL** of the units should be at the same level to avoid recirculation from one unit to another. If the unit discharge heights are different one or a combination of the following should be implemented. Either structural steel should be used to raise the air discharges of both units to the same level as shown in Figure 22, or a fan cowl should be added to the shorter unit, or the units should be spaced further apart than normally recommended.

Adequate spacing between the air inlets of the new and existing units must be provided. The air inlets for induced draft counterflow units are located on all four sides which may be different than the existing units. If this is the case, the guidelines for the minimum spacing between units (Tables 1 & 2) should be increased to allow adequate airflow to all units.

Another important consideration in a system expansion is the piping to both the existing and new units. **For cooling towers piped in parallel, the overflow levels of the new and existing units cold water basins MUST be at the same elevation. This takes precedence over the equal air discharge height requirement for induced draft units.** In some cases, fan cylinder extensions can be used so that the units have approximately the same discharge heights. Equalizer lines must be installed between adjacent units to balance the water levels of the basins during operation.

For induced draft condensers and closed circuit coolers, the discharge heights must be at the same elevation. Since each unit has its own independent spray water recirculation system, maintaining the overflow levels of the cold water basins is not necessary.

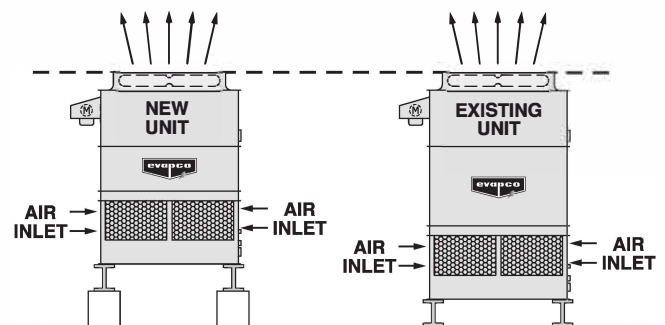

Figure 22 - Expansion to an Existing Installation

**NOTE: For installations where the minimum recommended distances cannot be maintained, contact your local representative or EVAPCO's Marketing Department for assistance with unit selection and layout.**

Refer to page 19 for additional information.

## Induced Draft Crossflow Unit Layout

### Single Unit Installations

The best place to locate any cooling tower is on a roof by itself. However, when this is not possible, correct layout guidelines must be followed to provide a satisfactory installation.

The first item to consider is the position of the unit with respect to other structures. The top of the cooling tower must be equal to or higher than any adjacent walls, buildings or other structures. When the top of the unit is lower than the surrounding structures (Figure 23), recirculation can be a major problem. If the unit is on the windward side, as shown in Figure 23, the discharge air will be forced against the building and then spread in all directions, including downward, toward the air inlets.

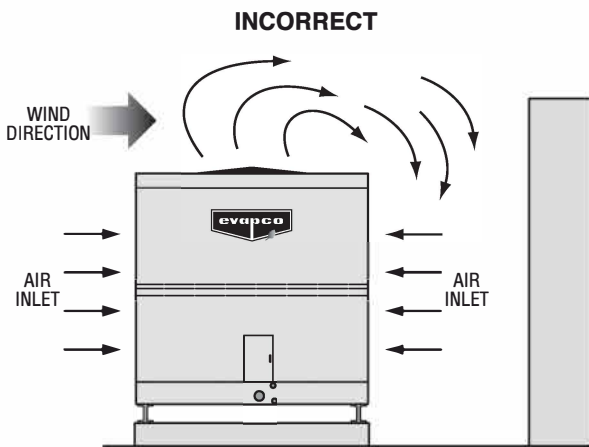

**Figure 23** - Installation with Top of Unit Lower than Top of Wall

When the wind comes from the opposite direction, the resulting negative pressure area created by the wind passing over the building will cause the discharge air to be forced back into the inlets, as shown in Figure 24. Even if neither of these conditions occurs, the presence of much taller structures can potentially inhibit the dissipation of the hot moist discharge air.

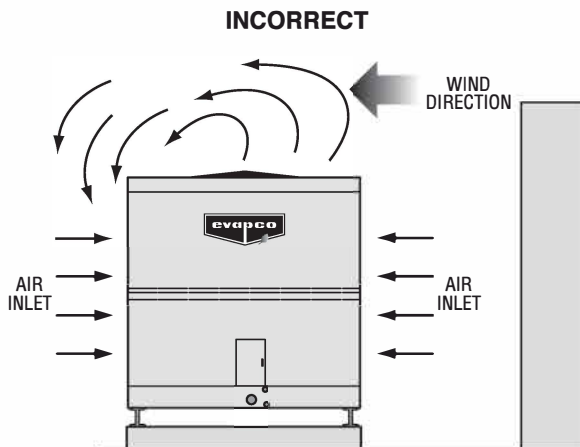

**Figure 24** - Wind Effect with Top of Unit Lower than Top of Wall

The conditions shown in Figures 23 & 24 can be corrected by elevating the unit on structural steel so that the top is higher than the adjacent structures, as shown in Figure 25. Fan cowl extensions can also be provided to elevate the fan discharge of the cooling tower to the proper height.

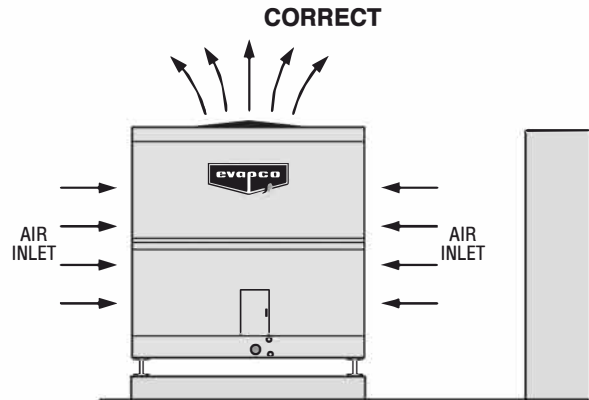

**Figure 25** - Installation Elevated so Top of Unit Is Higher than Top of Wall

When an induced draft, crossflow unit is located near a wall or other structure that blocks fresh air from entering the unit, consideration must be given to the clearance distance between the air inlets of the unit and this blockage, as shown in Figure 26. In this type of layout, air will be drawn in through the space between the unit and the wall or other structure as well as down from above. Therefore, it is important to provide adequate space in front of each air inlet to ensure proper air flow and prevent air recirculation.

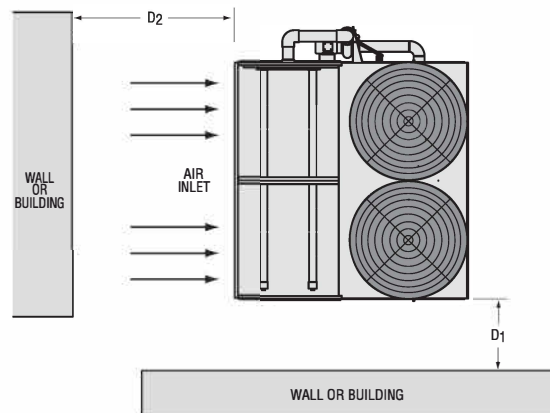

**Figure 26** - Installation Next to a Wall

When a unit is located near a building or wall, the minimum dimensions,  $D_1$  from the ends and  $D_2$  from the sides, as presented in Tables 3 and 4, must be maintained. Minimum dimensions  $D_1$  must be provided for piping, removal of access panels and for maintenance of the mechanical equipment. The  $D_2$  dimension has been developed to ensure that the unit is provided with adequate air flow.



**Table 3 – Minimum D<sub>1</sub> Dimensions**

| UNIT STYLE | MODELS    | Minimum Dimensions (m)<br>D <sub>1</sub> |          |            |           |
|------------|-----------|--|----------|------------|-----------|
|            |           | One Cell                                 | Two Cell | Three Cell | Four Cell |
| AXS        | All Sizes | 1  | 1        | 1          | 1         |

**Table 4 – Minimum D<sub>2</sub> Dimensions**

| UNIT STYLE | CELL SIZE<br>WxLxH<br>(m) | Minimum Dimensions (m)<br>D <sub>2</sub> |          |            |           |
|------------|---------------------------|--|----------|------------|-----------|
|            |                           | One Cell                                 | Two Cell | Three Cell | Four Cell |
| AXS        | 3.6x6.9x3.4               | 2.1                                      | 3.4      | 4.1        | 4.6       |
| AXS        | 3.6x6.9x6.8               | 2.3                                      | 3.7      | 4.7        | 5.5       |
| AXS        | 4.2x7.5x3.4               | 2.4                                      | 3.7      | 4.4        | 4.9       |
| AXS        | 4.2x7.5x6.8               | 2.4                                      | 4        | 5          | 5.8       |

**NOTE: Consult the factory on the D<sub>2</sub> dimension for applications with 5 or more cells.**

Sometimes other pieces of equipment such as pumps, filters, piping, etc. are placed in front of the air inlets. These obstructions should not be located any closer than the minimum dimensions shown in Table 4. Closer placements can create imbalances in the air flow which can adversely affect the unit performance.

**Multiple Unit and Large Installations**

When more than one induced draft crossflow unit is installed at the same location, the potential for recirculation becomes a greater concern. The following guidelines, however, will provide for satisfactory and efficient operation.

For installations utilizing two cooling towers, with air inlets facing each other, the units can be placed as shown in Figure 27. The minimum distance between the units, D<sub>3</sub>, must be maintained to provide adequate airflow as well as space for piping and access for maintenance. Table 5 gives the minimum recommended D<sub>3</sub> dimension. However, a more efficient method of configuring multiple cell crossflow cooling towers is shown in Figures 28 and 28a. The preferred method is to place the crossflow units in groups of two with "L" distance between the two groups where "L" is the unit length. This allows ease of access to each cell. For larger applications that have limited space, multiple crossflow cells can be placed as shown in the alternate method of Figure 28a with groups of two and three crossflow units placed "L" distance apart. It should be noted that access to the center cells can only be accomplished by passing through the outside cells. In addition, removal of the fan motors from the center cells becomes much more difficult when the cells are configured as shown in Figure 28a.

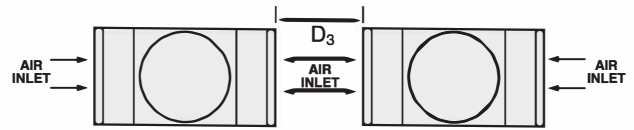

**Figure 27 - Multiple Units Placed Side-by-Side**

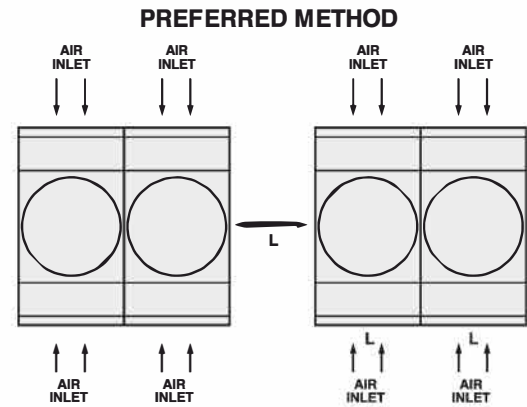

**Figure 28 - Multiple Units Placed End-to-End**

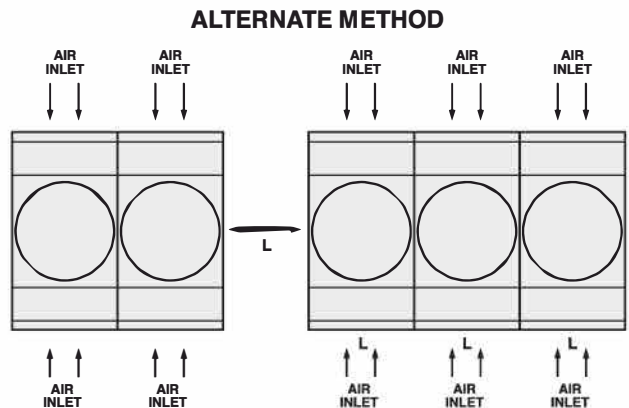

**Figure 28a - Multiple Units Placed End-to-End**

**Table 5 – Minimum D<sub>3</sub> Dimensions**

| UNIT STYLE | CELL SIZE<br>WxLxH<br>(m) | Minimum Dimensions (m)<br>D <sub>3</sub> |          |            |           |
|------------|---------------------------|--|----------|------------|-----------|
|            |                           | One Cell                                 | Two Cell | Three Cell | Four Cell |
| AXS        | 3.6x6.9x3.4               | 4.3                                      | 6.7      | 8.2        | 9.1       |
| AXS        | 3.6x6.9x6.8               | 4.6                                      | 7.3      | 9.4        | 11        |
| AXS        | 4.2x7.5x3.4               | 4.9                                      | 7.3      | 8.9        | 9.8       |
| AXS        | 4.2x7.5x6.8               | 4.9                                      | 11       | 10         | 11.6      |

**NOTE: Consult the factory on the D<sub>3</sub> dimension for applications with 5 or more cells.**

For large cooling tower installations that have 3, 4 or more units, it is imperative that the unit layout be carefully examined during the design of the system.

Very large multiple unit installations can create their own environment. Under certain weather and atmospheric conditions, the large quantities of discharge air will cause the wet bulb temperature in the immediate area to be higher than the local design data. The minimum dimensions shown in Tables 3, 4 and 5 should be increased whenever possible in order to allow for an additional safety factor. The amount of increase is dependent on the number of units, type of installation, existing equipment and unit surroundings.

The surrounding area plays an important part in the design of a large installation. Locating a large installation in a valley or between buildings will increase the chances that the discharge air will recirculate, thereby raising the entering wet bulb temperature. If it is determined that the surrounding conditions could cause recirculation, the units must be spaced properly and sized at the anticipated entering wet bulb conditions.

Another important consideration when dealing with larger multiple unit installations is prevailing winds. Although prevailing wind conditions generally change with the season, the wind direction during the hottest part of the year is of utmost importance. To minimize the potential for recirculation, it is best to locate the units so that the prevailing wind is oriented as shown in Figure 29.

**Consult your local representative or EVAPCO's Marketing Department for recommended layout guidelines for very large multiple unit installations.**

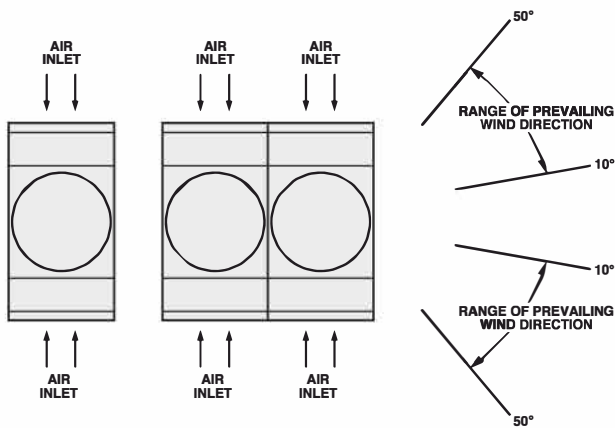

**Figure 29 - Prevailing Wind**

### Special Enclosures

Occasionally, induced draft crossflow units are installed in an enclosure. These installations require special consideration of the unit layout to ensure trouble free operation. Typical installations consist of units installed in solid wall or louvered enclosures or units that are located in a well.

### Solid Wall Enclosures or Wells

One typical enclosure is a unit installed in a well (Figure 30). When considering a single unit adjacent to a solid wall enclosure or located in a well, the minimum  $D_1$  dimension, as shown in Table 3, must be maintained to allow room for servicing the unit. The unit should be oriented so that the air flows uniformly to the two air inlets of the unit. The air discharge of the unit must be level with or higher than the surrounding walls.

In the well type enclosure, all the air must be brought down from above and can be susceptible to recirculation. Field experience has demonstrated that the downward velocity of the supply air into the well must be kept **BELOW 2m/s** to avoid the effects of recirculation.

To calculate the downward velocity, the total air flow for the unit is divided by the usable well area. The usable well area is as shown in Figure 30.

For a new installation, the W dimension must be determined. Calculating this dimension is somewhat of an iterative process. Also note that the minimum W dimension will vary for each application. A crossflow tower well layout will be acceptable once the minimum W dimension is determined that ensures the download velocity into the well is **2m/s or less**.

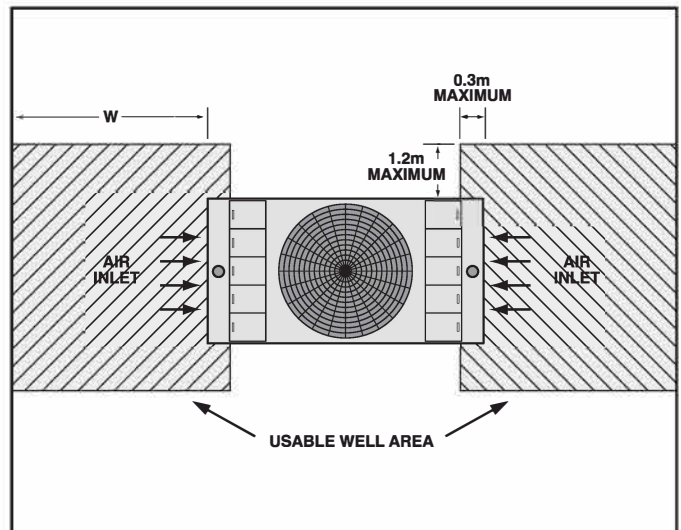

**Figure 30 - Well Installation**

## Louvered Wall Enclosures

Induced draft crossflow units can also be installed in enclosures with louvered or slotted walls (Figure 31). With this type of enclosure, the air flow patterns will be a mixture of the open type and well installations. The inlet air will be drawn from the top and through the louvers or slotted openings.

Since the air will follow the path of least resistance, the pressure drop through the louvers will determine how much air is drawn from both areas. To minimize the potential for recirculation, it is better to draw most of the air through the louvers. Therefore, it is important that the louvers are designed for minimum pressure drop. **To achieve this goal, the velocity through the louvers should be maintained at or below 3m/s, the louvers should have a minimum of 50% net free area, and the air inlets should face the louvers.**

The first step in checking a louvered type enclosure is to treat it as a well enclosure and calculate the downward air velocity assuming that all the air must enter from the top. If the layout meets the requirements of a well installation, then the louvered enclosure will work regardless of the size of the louvers.

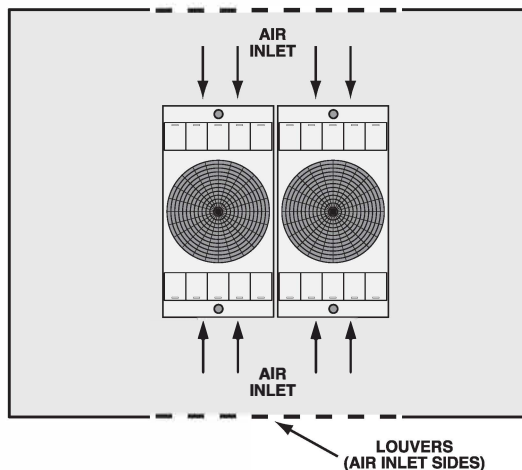

Figure 31 - Louvered Wall Enclosure

If the layout does not meet the requirements of a well installation, then another formula must be used. This formula, proven by years of field experience, assumes that **ALL** the air is drawn through the louvers. The total air flow for the unit is divided by the net free louver area. The resultant air velocity must be **BELOW 3m/s**. In addition to meeting this minimum louver velocity, the installation must also meet the following requirements. The minimum air inlet to louver dimension must be 0.9m and the minimum space requirements, for maintenance, as shown on page 19, must also be maintained.

## Expansions to Existing Systems

Expansions to existing systems present the same concerns as multiple unit installations. However, there are additional concerns that must be evaluated when planning a cooling tower expansion. Since in an expansion the new unit may not be identical to the existing one, it is important to examine the heights of the new and the existing units. Whenever possible, the tops of **ALL** of the units should be at the same level to avoid recirculation from one unit to another. If the unit discharge heights are different one or a combination of the following should be implemented. Either structural steel should be used to raise the air discharges of both units to the same level as shown in Figure 32, or a fan cowl should be added to the shorter unit, or the units should be spaced further apart than normally recommended.

Adequate spacing between the air inlets of the new and existing units must be provided. The air inlets for induced draft crossflow units are located on two sides which may be different than the existing units. If this is the case, the guidelines for the minimum spacing between units (Table 5) should be increased to allow adequate airflow to all units.

Another important consideration in a system expansion is the piping to both the existing and new units. **For cooling towers piped in parallel, the overflow levels of the new and existing units cold water basins MUST be at the same elevation. This takes precedence over the equal air discharge height requirement for induced draft units.** In some cases, fan cylinder extensions can be used so that the units have

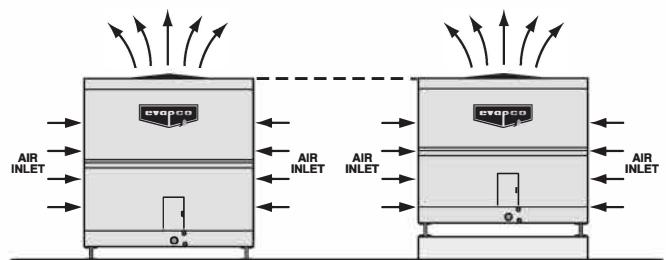

Figure 32 - Expansion to an Existing Installation

approximately the same discharge heights. Equalizer lines must be installed between adjacent units to balance the water levels of the basins during operation.

**NOTE: For installations where the minimum recommended distances cannot be maintained, contact your local representative or EVAPCO's Marketing Department for assistance with unit selection and layout.**

Refer to page 19 for additional information.

## Forced Draft Unit Layout

### Single Unit Installations

The best place for a cooling tower is on a roof by itself. However, when this is not possible, correct layout guidelines must be followed to provide a satisfactory installation. There are various types of forced draft units that are discussed in this section, which include both centrifugal and axial fan types. The centrifugal fan models include units with single side air inlets. Also included in this section are layout guidelines for EVAPCO's centrifugal fan LR/LP end air inlet units. Special consideration is required for external service platforms available on PM style units, see platform drawing for dimensions.

The first item to consider is the position of the unit with respect to other structures. The top of the cooling tower must be higher than any adjacent walls, buildings or other structures. When the top of the unit is lower than the surrounding structures (Figure 33), recirculation can be a major problem. If the unit is on the windward side, as shown in Figure 33, the discharge air will be forced against the building then spread in all directions, including downward, toward the fan inlets.

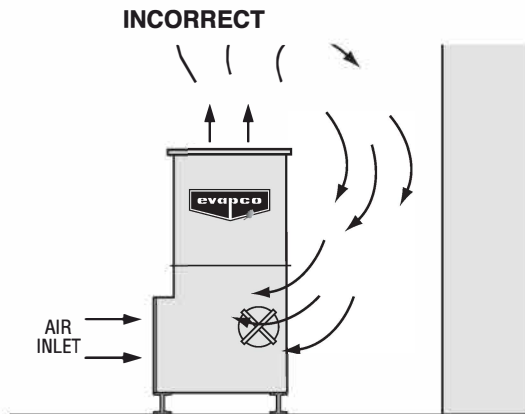

**Figure 33** - Installation with Top of Unit Lower than Top of Wall

When the wind comes from the opposite direction, the resulting negative pressure area created by the wind passing over the building will cause the discharge air to be forced back into the inlets, as shown in Figure 34. Even if neither of these conditions occurs, the presence of much taller structures can inhibit the dissipation of the hot moist discharge air.

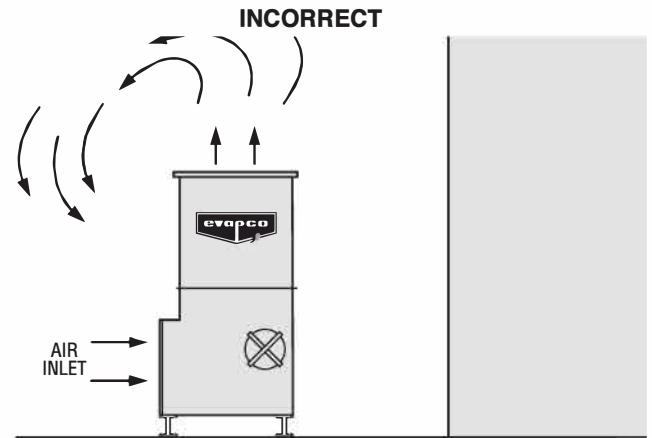

**Figure 34** - Wind Effect with Top of Unit Lower than Top of Wall

There are two simple methods to correct this recirculation problem. The first method is to elevate the unit on structural steel so that the top is higher than the adjacent structure, as shown in Figure 35.

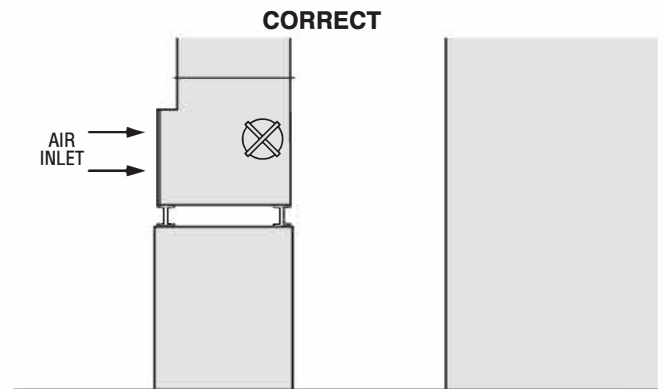

**Figure 35** - Installation Elevated so Top of Unit is Higher than Top of Wall

The second method is to install a tapered discharge hood (Figure 36) which discharges the air above the height of the structure. The discharge hood increases the discharge air velocity, which works to minimize the potential of recirculation. However, the addition of a discharge hood increases the external static pressure that the fans must overcome which may require the next larger size fan motor. **For installations where neither of these options are possible, an experienced engineering decision must be made regarding the potential of a performance impact.**

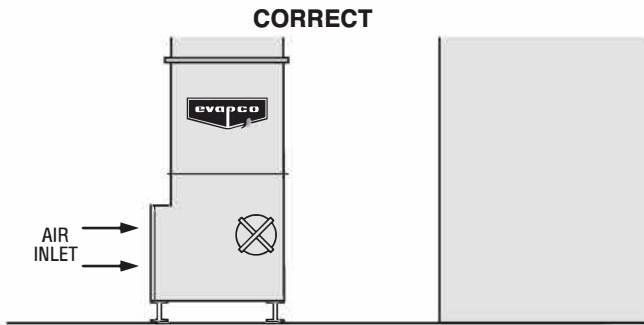

**Figure 36** - Installation with Top of Discharge Hood Above Top of Wall

When a cooling tower is located near a wall, it is best for the air inlet to face away from the wall, as shown in Figure 37.

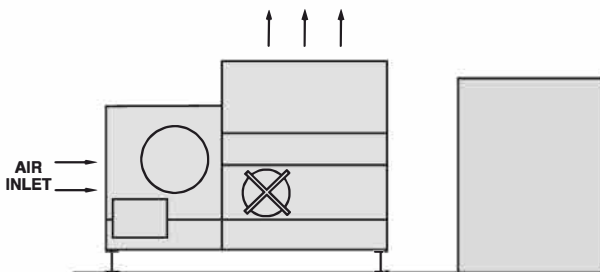
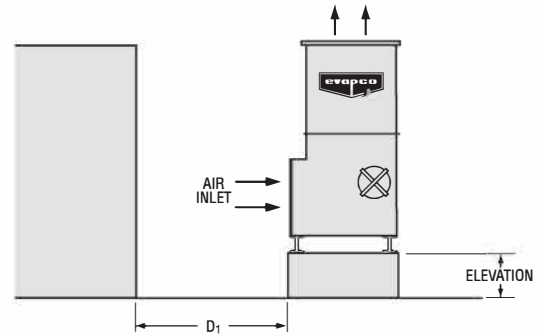

**Figure 37** - Installation Next to Wall, Best Orientation

If this is not possible and the air inlets must face the wall, as shown in Figure 38, then a minimum distance  $D_1$  must be maintained between the wall and the unit, as listed in Table 6. Table 6 provides the minimum dimension  $D_1$  for all of the various sizes of both centrifugal and axial fan forced draft units. For installations next to walls, all of the air consumed by the unit is drawn in through the space between the unit and the wall and also down from above. The downward draw of air to the unit is why it is so critical to provide the minimum  $D_1$  dimension to prevent recirculation of the discharge air.

The distances for  $D_1$  in Table 6 have been developed using a formula based on years of successful experience that assumes all the air is fed in from the ends at less than 3m/s. As can be seen from the data in Table 6, elevating a forced draft unit on structural steel will allow the  $D_1$  dimension to be reduced.

This dimension can be reduced because the end area is effectively increased by the amount the unit is elevated. Elevating an axial fan unit has no impact on the  $D_1$  dimension.



**Figure 38** - Installation Next to Wall

**Table 6**  
Minimum Distance  $D_1$  from Unit to Wall  
with Air Inlet Facing Wall

**1m & 1.5m Wide Models—LR/LP End Air Inlet**

| Unit Width (m) | Unit Length (m) | Unit Elevation (m) |     |     |            |
|----------------|-----------------|--------------------|-----|-----|------------|
|                |                 | 0                  | 0.6 | 0.9 | $\geq 1.2$ |
| 1              | 1.8*            | 1.2                | 1.2 | 1   | 1          |
| 1.5            | 1.8*            | 1.2                | 1.2 | 1   | 1          |
| 1.5            | 2.7* & 3.6*     | 1.5                | 1.4 | 1.4 | 1.2        |

**2.4m Wide Models—LR/LP End Air Inlet**

| Unit Length (m) | Unit Elevation (m) |     |     |            |
|-----------------|--------------------|-----|-----|------------|
|                 | 0                  | 0.6 | 0.9 | $\geq 1.2$ |
| 2.7* & 3.6*     | 1.8                | 1.7 | 1.7 | 1.5        |

**1.2m & 1.6m Wide Models—Single Fan Side**

| Unit Length (m) | Unit Elevation (m) |     |     |            |
|-----------------|--------------------|-----|-----|------------|
|                 | 0                  | 0.6 | 1.2 | $\geq 1.8$ |
| to 2.7          | 1.2                | 1.2 | 1.2 | 1.2        |
| 3.6             | 1.5                | 1.2 | 1.2 | 1.2        |
| 5.5             | 1.8                | 1.5 | 1.2 | 1.2        |

**2.4m & 3m Wide Models—Single Fan Side**

| Unit Length (m) | Unit Elevation (m) |     |     |            |
|-----------------|--------------------|-----|-----|------------|
|                 | 0                  | 0.6 | 1.2 | $\geq 1.8$ |
| to 3.6          | 2.1                | 2   | 1.8 | 1.8        |
| 5.5             | 2.4                | 2.1 | 1.8 | 1.8        |
| 7.3             | 3                  | 2.7 | 2.4 | 2.1        |
| 11              | 4.3                | 3.6 | 3.3 | 3          |

**3.6m Wide Models—Single Fan Side**

| Unit Length (m) | Unit Elevation (m) |     |     |            |
|-----------------|--------------------|-----|-----|------------|
|                 | 0                  | 0.6 | 1.2 | $\geq 1.8$ |
| to 3.6          | 2.4                | 2.1 | 2.1 | 2.1        |
| 5.5             | 2.7                | 2.4 | 2.1 | 2.1        |
| 7.3             | 3.3                | 3   | 2.7 | 2.4        |
| 11              | 4.8                | 4.3 | 3.6 | 3.3        |

\* Note: The length for the LR/LP end air inlet unit includes the casing section only, not the entire unit length.

If the required  $D_1$  distance shown in Table 6 is too large for the available space, the use of a tapered discharge hood (Figure 39) can reduce the distance. The tapered discharge hood should be at least 0.9m tall with an exit air velocity between 6m/s and 7.5m/s. The use of a tapered discharge hood will allow the distances given in Table 6 to be reduced by 20 percent. However, the minimum  $D_1$  distance should never be less than:

- 1m and 1.5m Wide Models - LR/LP – End Air Inlet = 0.9m**
- 2.4m Wide Models - LR/LP – End Air Inlet = 0.9m**
- 1.2m and 1.6m Wide Models – Single Fan Sided = 1.2m**
- 2.4m and 3m Wide Models – Single Fan Sided = 1.8m**
- 3.6 Wide Models – Single Fan Sided = 2.1m**

In some installations, other pieces of equipment such as receivers, compressors, piping, etc. are placed in front of the fan inlet. These should not be any closer than the above minimum dimensions. Closer placement can create imbalances in the air flow which has an adverse affect on fan performance.

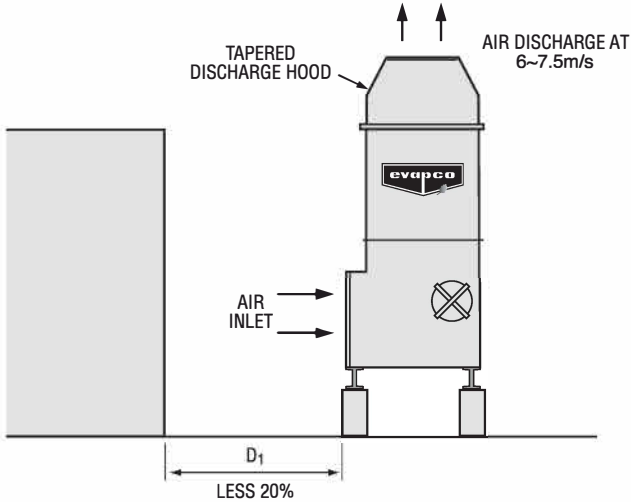

**Figure 39 - Installation with Tapered Discharge Hood**

### Multiple Unit & Large Installations

When more than one cooling tower is installed at the same location, the potential for recirculation becomes a bigger concern because of the larger quantities of air being handled. The following guidelines, however, will provide for satisfactory and efficient operation.

When dealing with installations using two units they should be placed either back-to-back, as shown in Figure 40 (the preferred position), or end-to-end, as shown in Figures 41 and 42. The only difference between the layouts shown in Figures 41 and 42 is that additional space is required when connection ends face each other (Figure 42).

In installations with three or more cooling towers where it is necessary for the fan inlets of two units to face each other (Figure 43), then the minimum distance  $D_2$  between fan inlets must be per Table 7, as shown on page 15.

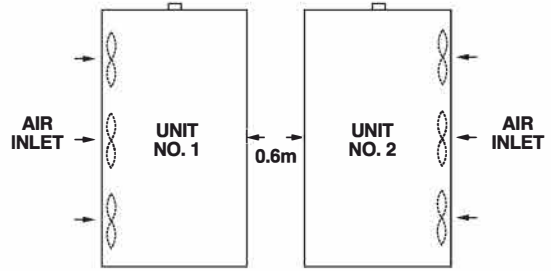

**Figure 40 - Multiple Units Placed Back-to-Back**

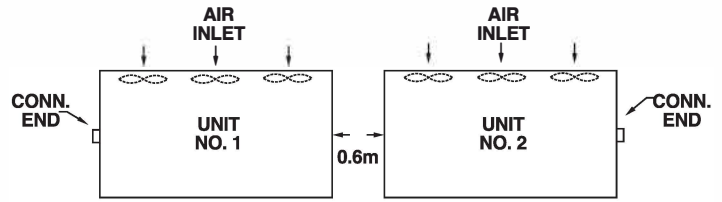

**Figure 41 - Multiple Units Placed End-to-End**

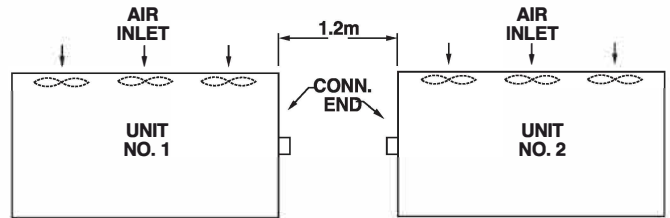

**Figure 42 - Multiple Units Placed End-to-End**

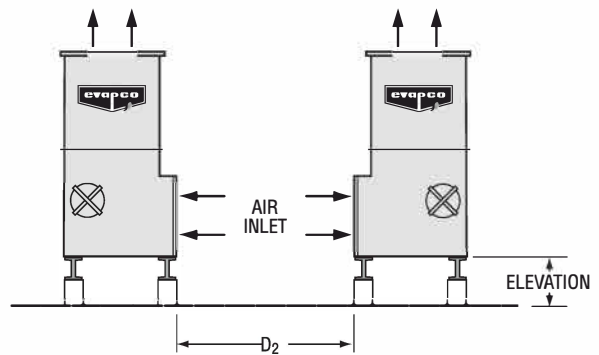

**Figure 43 - Installation with Air Inlets Facing Each Other**

These tables are based on formulas which assume all the air flows to the units from the ends at velocities of less than 3m/s. This criteria has been proven through years of successful experience with evaporative cooling installations.

If there is not enough room to meet the minimum distances given in Table 7, the use of tapered discharge hoods may provide a good solution. These hoods should be designed as previously described, i.e. a minimum of 0.9m tall with an exit air velocity between 6m/s and 7.5m/s. The distances in Table 7 can be reduced 20%. However, the spacing between the fan inlets even with discharge hoods, cannot be less than the minimums shown at the top of the next column.

**Table 7**  
**Minimum Distance D<sub>2</sub>**  
**Units with Air Inlets Facing Each Other**

**1m & 1.5m Wide Models—LR/LP End Air Inlet**

| Unit Width (m) | Unit Length (m) | Unit Elevation (m) |     |     |       |
|----------------|-----------------|--------------------|-----|-----|-------|
|                |                 | 0                  | 0.6 | 0.9 | ≥ 1.2 |
| 1              | 1.8*            | 2.4                | 2.4 | 2.1 | 2.1   |
| 1.5            | 1.8*            | 2.4                | 2.4 | 2.1 | 2.1   |
| 1.5            | 2.7* & 3.6*     | 3                  | 2.7 | 2.7 | 2.4   |

**2.4m Wide Models—LR/LP End Air Inlet**

| Unit Length (m) | Unit Elevation (m) |     |     |       |
|-----------------|--------------------|-----|-----|-------|
|                 | 0                  | 0.6 | 0.9 | ≥ 1.2 |
| 2.7* & 3.6*     | 3.6                | 3.3 | 3.3 | 3     |

**1.2m & 1.6m Wide Models—Single Fan Sided**

| Unit Length (m) | Unit Elevation (m) |     |     |       |
|-----------------|--------------------|-----|-----|-------|
|                 | 0                  | 0.6 | 1.2 | ≥ 1.8 |
| to 2.7          | 2.4                | 2.1 | 1.6 | 1.8   |
| 3.6             | 3                  | 2.4 | 2.1 | 1.8   |
| 5.5             | 3.6                | 3   | 2.4 | 1.8   |

**2.4m & 3m Wide Models—Single Fan Sided**

| Unit Length (m) | Unit Elevation (m) |     |     |       |
|-----------------|--------------------|-----|-----|-------|
|                 | 0                  | 0.6 | 1.2 | ≥ 1.8 |
| to 3.6          | 4.3                | 4   | 3.6 | 3     |
| 5.5             | 4.8                | 4.3 | 3.6 | 3     |
| 7.3             | 6                  | 5.5 | 4.8 | 4.3   |
| 11              | 8.5                | 7.3 | 6.7 | 6     |

**3.6m Wide Models—Single Fan Sided**

| Unit Length (m) | Unit Elevation (m) |     |     |       |
|-----------------|--------------------|-----|-----|-------|
|                 | 0                  | 0.6 | 1.2 | ≥ 1.8 |
| to 3.6          | 4.8                | 4.6 | 4.3 | 3.3   |
| 5.5             | 5.5                | 4.8 | 4.3 | 3.3   |
| 7.3             | 7                  | 6   | 5.5 | 4.8   |
| 11              | 9.7                | 8.2 | 7.6 | 7     |

\* Note: The length for the LR/LP end air inlet unit includes the casing section only, not the entire unit length.

- 1m & 1.5m Wide Models - LR/LP –End Inlet = 1.8m - Side Inlet = 1.2m**
- 2.4m Wide Models - LR/LP – End Inlet = 3m - Side Inlet = 1.2m**
- 1.2m and 1.6m Wide Models – Single Fan Sided = 1.8m**
- 2.4m and 3m Wide Models – Single Fan Sided = 3m**
- 3.6m Wide Models – Single Fan Sided = 3.3m**

Very large multiple unit installations can create their own environment. Under certain weather and atmospheric conditions the large quantities of discharge air will cause the wet bulb temperature in the immediate area to be higher than local design data. The minimum dimensions shown in Tables 6 and 7 should be increased whenever possible in order to allow for an additional safety factor. The amount of increase is dependent on the number of units, type of installation, existing equipment, and unit surroundings.

The surrounding area plays an important part in the design of a large installation. Locating a large installation in a valley, or between buildings will increase the chances that the discharge air will recirculate, thereby raising the entering wet bulb temperature.

Another important consideration when dealing with larger multiple unit installations is prevailing winds. Although prevailing wind conditions generally change with the season, the wind direction during the hottest part of the year is of utmost importance. To minimize the potential for recirculation, it is best to locate the cooling tower so that the air inlets are nearly perpendicular to the prevailing wind direction (Figure 44). The object is to orient the units so that the prevailing wind does not blow the discharge air into the fan inlets.

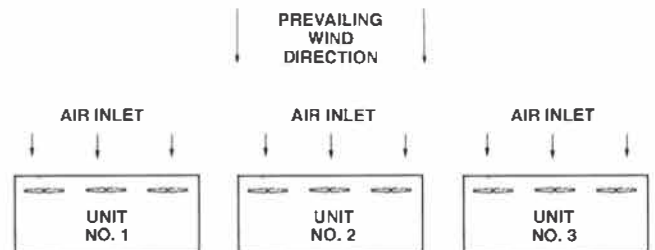

**Figure 44 - Large Installation—Units End-to-End**

For installations where the units are laid out back-to-back, the best orientation of the prevailing wind is shown in Figure 45.

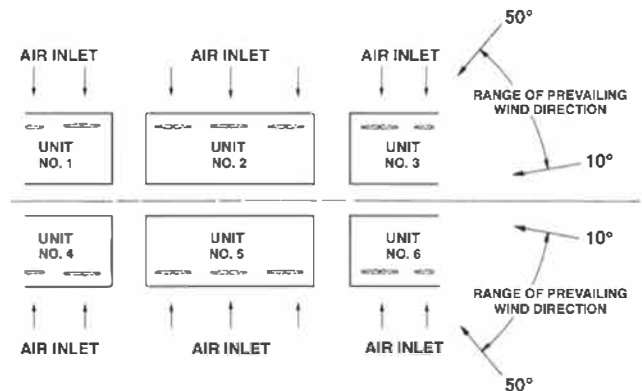

**Figure 45 - Large Installation—Units Back-to-Back**

## Special Enclosures

Many times cooling towers are installed in an enclosure. These installations require special consideration of the unit layout to ensure trouble free operation.

### Solid Wall Enclosures or Wells

One typical enclosure situation is a unit installed in a well (Figure 46). When considering a single unit adjacent to a solid wall enclosure or well, the D1 dimension found in Table 6, page 13 must be used as an **ABSOLUTE** minimum. The cooling tower should be oriented so that the air flows uniformly to the air inlets and the area on the fan side is maximized. The air discharge of the unit must be level with or higher than the surrounding walls.

In the well type enclosure, all the air must be brought down from above and can be susceptible to recirculation. Field experience has demonstrated that the downward velocity of the supply air must be kept **BELOW 1.5m/s** to avoid the effects of recirculation.

**The downward air velocity within some enclosures may exceed the maximum 1.5m/s. In these situations, a tapered discharge hood can be used allowing the maximum downward air velocity to be increased from 1.5m/s to 2.3m/s.**

To calculate the downward air velocity, the total air flow for the unit is divided by the usable well area. The usable well area (shaded portion of Figures 46 and 46a) is the area around the unit from which air can be drawn. For towers with a single fan sided air inlet, Figure 46, the usable well area includes the space in front of the unit extending up to 1.8m on each end plus half of the unit width in depth. The usable well area for towers with a single end air inlet, Figure 46b, includes the space in front of the air inlet extending up to 1.8m from each side.

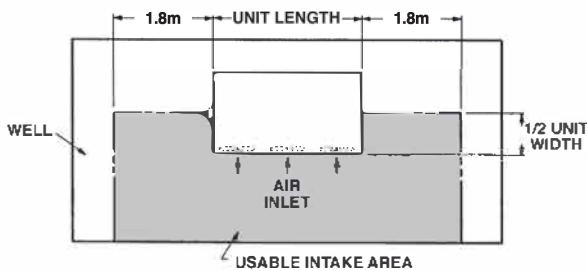

Figure 46 - Well Installation

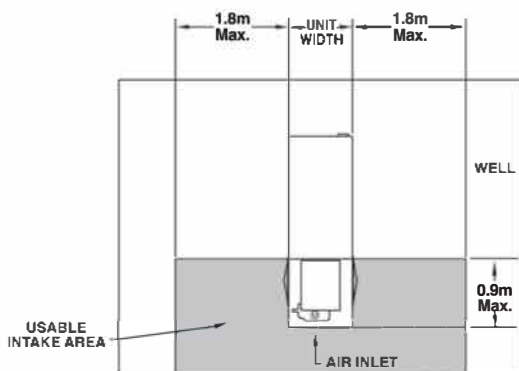

Figure 46a - Well Installation

**Note: Units with solid bottom panels or inlet sound attenuation, the usable well area is reduced. Only utilize the space in the front of the air inlets.**

### Louvered Wall Enclosures

Forced draft units can also be installed in enclosures with louvered or slotted walls and an open top (Figure 47). With this type of enclosure, the air flow patterns will be a mixture of the open type and well installations. The inlet air will be drawn down from the top and through the louvers or slotted openings.

Since the air will follow the path of least resistance, the pressure drop through the louvers will determine how much air is drawn from both areas. To minimize the potential for recirculation, it is better to draw most of the air in through the louvers. Therefore, it is important that the louvers are designed for minimum pressure drop. **To achieve this goal, the air velocity through the louvers should be maintained at or below 3m/s, the louvers should have a minimum of 50% net free area and the air inlet should face the louvers.**

The first step in checking a louvered type enclosure is to treat it as a well enclosure and calculate the downward air velocity assuming that all the air comes down from the top. If the downward air velocity is equal to or less than 1.5m/s, then the louvered enclosure will work regardless of the size of the louvers.

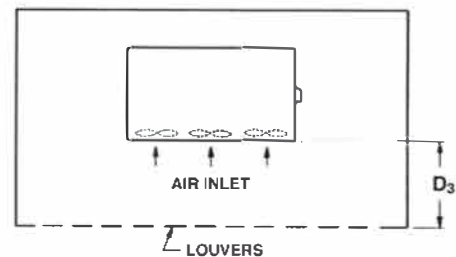

Figure 47 - Louvered Wall Enclosure with Front Louvers

If the downward air velocity into the enclosure is greater than 1.5m/s, then another formula is used. This formula, proven by years of field experience, assumes that **ALL** of the air is drawn through the louvers. The total air flow for the unit is divided by the net free louver area. The resultant air velocity must be **BELOW 3m/s**. The installation must also meet the minimum fan inlet to louver dimension ( $D_3$ ) as shown in Table 8 on page 17 and the minimum space requirements for maintenance as shown on page 19.

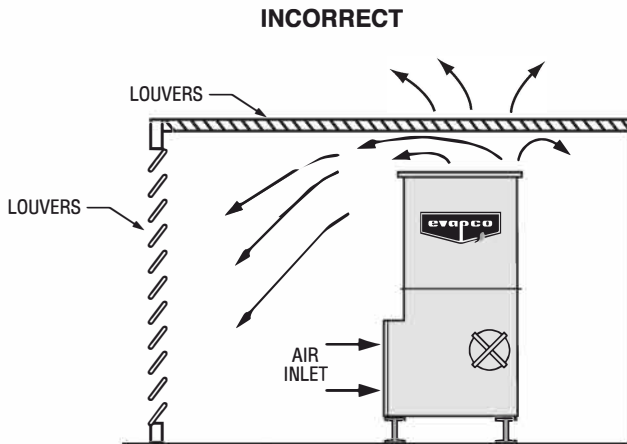

**Table 8**  
**Minimum Distance  $D_3$  from Louvers to Fan Inlets**

| Type of Unit                                     | Distance (m) |
|--|--------------|
| 1m Wide Models - LR/LP – End Air Inlet           | 0.9          |
| 1.5m and 2.4m Wide Models - LR/LP –End Air Inlet | 1.2          |
| 1.2m and 1.6m Wide Models – Single Fan Sided     | 1.2          |
| 2.4m and 3m Wide Models – Single Fan Sided       | 1.8          |
| 3.6m Wide Models – Single Fan Sided              | 2.1          |

### Grating Over Well

There are times that grating may be installed on top of an enclosure. The discharge area of the cooling tower must not be covered by any grating. If the grating covers the top of the unit, recirculation will occur, as shown in Figure 48. The correct method is to install the unit so that its discharge is above the grating, as shown in Figure 49.



**Figure 48 - Louvered Enclosure with Grating Over Top**

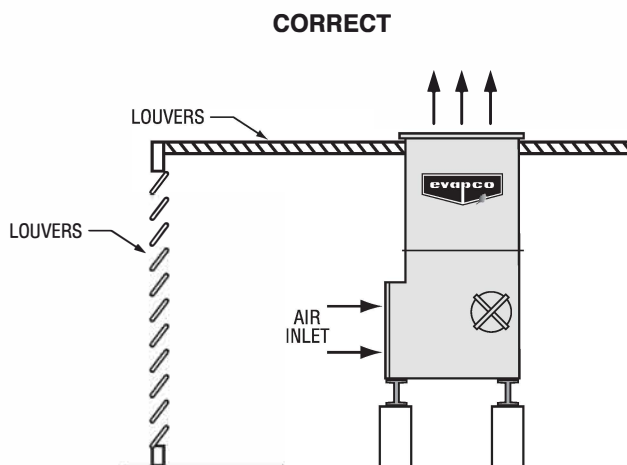

**Figure 49 - Louvered Enclosure with Grating Over Top**

### Indoor Installations

Occasionally, centrifugal fan cooling towers are installed indoors where they normally require ductwork to and from the unit. In these instances, the fan motor size and fan speed must be increased due to the external static pressure imposed by the ductwork. Most centrifugal fan towers can handle up to 125Pa of external static pressure by increasing the fan motor one size with a corresponding increase in fan speed. For cases where external static pressure exceeds 125Pa, the tower manufacturer should be consulted. In all cases, the manufacturer must be advised what external static pressure the unit will be subjected to so that the fan motors and drives can be properly sized.

The outside air for the unit can travel from a louver or slotted opening either through ductwork or by having the room act as a plenum. In the second case, where the room is acting like a plenum (Figure 50), the air velocity through the louvers feeding air to the unit should be limited to a maximum of 4m/s.

When a room is used as a plenum, other equipment may be located in front of the air inlets. This equipment should not be closer than the minimum distances shown below.

#### Single Fan Sided Units

- 1.2m and 1.6m Wide Models - 0.9m
- 2.4m and 3m Wide Models - 1.5m
- 3.6m Wide Models - 1.8m

#### LR/LP - End Air Inlet Units

- 1m Wide Models - 1.2m
- 1.5m Wide x 1.8m Long Models - 1.2m
- 1.5m Wide x 2.7m & 3.6m Long Models - 1.5m
- 2.4m Wide Models - 1.8m

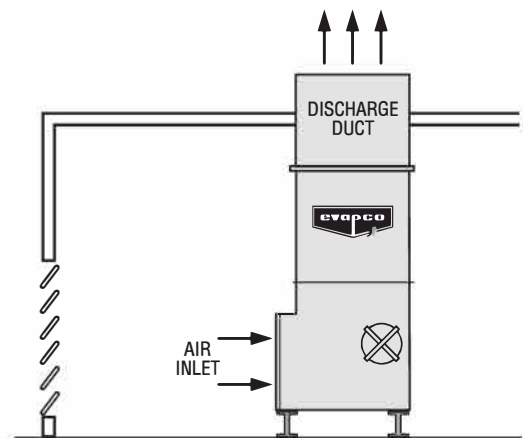

**Figure 50 - Indoor Installation with Floor Acting as Plenum**

When the inlet and discharge air are ducted to and from the unit, it is important to minimize pressure losses in the ductwork by keeping the air velocities low and by avoiding changes in direction whenever possible. The duct should be sized for a maximum of 4m/s. for the inlet air and a maximum of 5m/s. for the discharge air. Any horizontal turns at the unit should be designed by using the 70% rule as shown in Figures 51 and 52.

**NOTE: Make sure that adequately sized access doors are located in both the inlet and discharge ductwork which will allow the unit to be accessed for maintenance.**

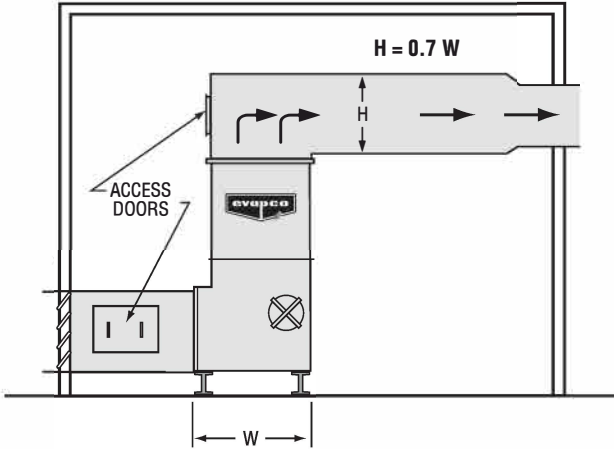

Figure 51 - Indoor Installation with Ductwork

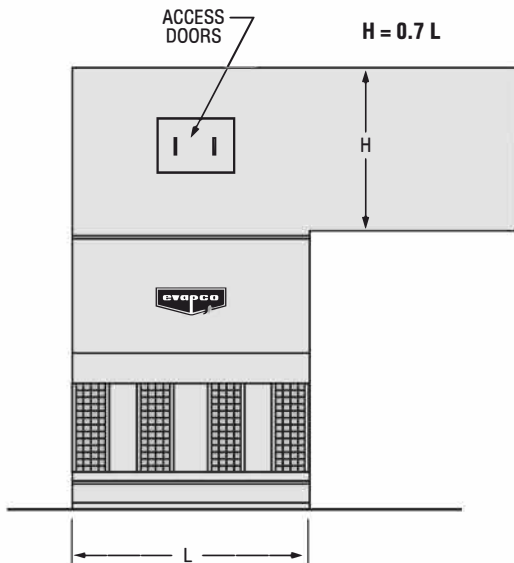

Figure 52 - Indoor Installation with Ductwork

Note: The length for the LR/LP end air inlet unit includes the casing section only, not the entire unit length.

## Expansions to Existing Systems

Expansions or additions to existing systems present the same concerns as multiple unit installations. However, there are additional concerns that must be evaluated when planning a cooling tower expansion. Since in an expansion the new cooling tower may not be identical to the existing one, it is important to examine the heights of the new and the existing units. Whenever possible, the tops of **ALL** of the units should be at the same level to avoid recirculation from one unit to another. If the unit discharge heights are different one or a combination of the following should be implemented. Either structural steel should be used to raise the air discharges of both units to the same level as shown in Figure 53, or a straight sided discharge hood should be added to the shorter unit, or the units should be spaced further apart than normally recommended.

If the units are placed with fans facing each other, use the data in Table 7, page 15, which lists the minimum distances ( $D_2$ ) between adjacent fan sections, to obtain the correct unit spacing. If the units are of unequal size, use the Table 7 data for the smaller of the two units and increase the distance by 20%.

Another important consideration in a system expansion is the piping to both the existing and new units. **For cooling towers piped in parallel, the overflow levels of the new and existing units cold water basins MUST be at the same elevation. This takes precedence over the equal air discharge height requirement.** In some cases, straight sided discharge hoods can be used so that the units have approximately the same discharge heights. Equalizer lines must be installed between adjacent units to balance the water levels of the basins during operation.

For forced draft condensers and closed circuit coolers, the discharge heights must be at the same elevation. Since each unit has its own independent spray water recirculation system, maintaining the overflow levels of the cold water basins is not necessary.

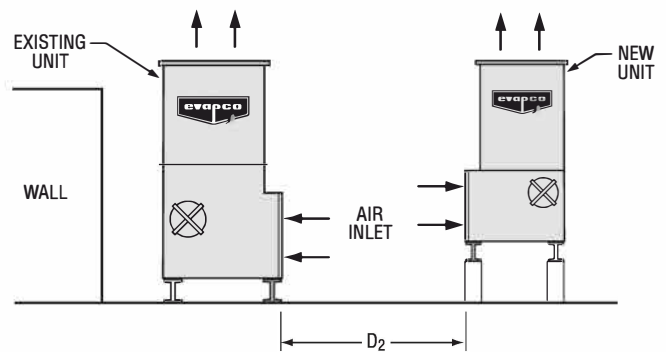

Figure 53 - Expansion to an Existing Installation

**NOTE: For installations where the minimum recommended distances cannot be maintained, contact your local representative or EVAPCO's Marketing Department for unit selection and layout.**

Refer to page 19 for additional information.

## Other Layout Criteria

In our discussion of locating cooling towers, closed circuit coolers, and condensers, our concern has been to provide adequate fresh air to the unit and minimize the potential for recirculation. However, there are several other criteria which also must be considered before determining the final layout of the units. The cooling tower installation shall provide adequate space for maintenance and the associated piping.

### Space Requirements for Maintenance

When a unit is located in close proximity to other structures, walls or equipment, there are minimum clearances required for periodic maintenance. Proper access must be provided for:

- 1) Adjustment and replacement of drive belts
- 2) Lubrication of fan shaft bearings
- 3) Cleaning of the water distribution system
- 4) Access to the cold water basin for cleaning
- 5) Access to the pumps of closed circuit coolers and condensers for maintenance.

The minimum dimensions for service are shown for forced draft units (Figures 54 & 55) and induced draft counterflow units (Figure 56) and crossflow units (Figure 57) and apply for all installations i.e., single units, multiple units, units in enclosures, etc. A unit which is located so that the periodic routine maintenance can be accomplished easily will receive the proper care. A unit that does not have adequate space for maintenance and is hard to service will NOT get proper care which will reduce its performance and useful life.

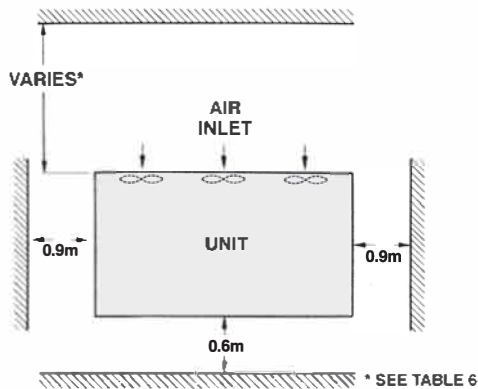

Figure 54 - Minimum Clearance Dimensions Forced Draft Units

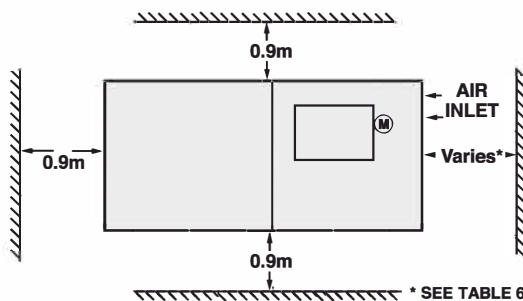

Figure 55 - Minimum Clearance Dimensions Forced Draft Units (LR/LP - End Air Inlet)

Also, in addition to the periodic maintenance items, unit drawings must be reviewed to ensure there is room for any future major repair work. Space should be provided to allow for the replacement of a fan motor, pump, fan, or fan shaft.

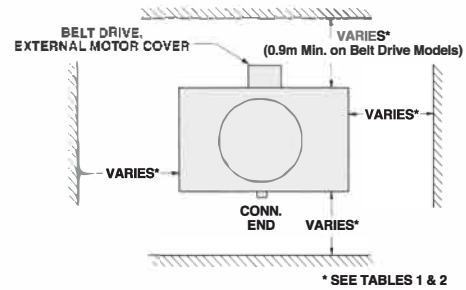

Figure 56 - Minimum Clearance Dimensions Induced Draft Counterflow Units

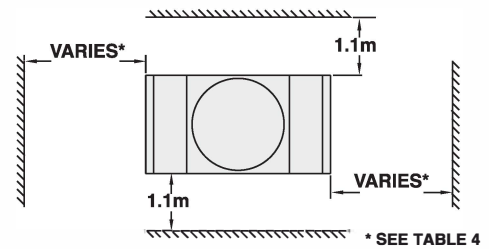

Figure 57 - Minimum Clearance Dimensions Induced Draft Crossflow Units

### Space Requirements for Unit Piping

The piping design for each installation can be an important aspect in locating evaporative cooling equipment. There are two key piping considerations which should always be reviewed.

#### A. Sufficient Unit Elevation

The location of a unit is often influenced by the piping design. Adequate unit elevation is required to prevent pump cavitation and provide free drainage of the water from the cold water basin. When locating an evaporative condenser, the height required for piping is particularly important. Unit elevation must be sufficient to provide adequate height for the trapped liquid line and the sloping of the drain line leading to the high pressure receiver. For additional information concerning refrigeration pipe sizing and layout, see EVAPCO Bulletin 131A "Piping Evaporative Condensers".

#### B. Spacing for Future Expansion

Space for piping of additional units should be reserved in the initial plan. When installing a single unit, it is important to consider where additional units would be placed and locate the single unit so that future expansion will be as simple as possible. If the expansion is planned in the near future, it is normally more economical to install branch connections with valves during the initial installation rather than with the expansion. Not only should room for piping the future unit be considered but, also the layout should be treated as a multiple unit installation with the required spacing that will allow proper airflow for the existing and possible future units.



# OUR PRODUCTS ARE MANUFACTURED WORLDWIDE



 World Headquarters/  
Research and  
Development Center

 EVAPCO Facilities



## EVAPCO, Inc. — World Headquarters & Research / Development Center

P.O. Box 1300 • Westminster, MD 21158 USA  
410.756.2600 • [marketing@evapco.com](mailto:marketing@evapco.com) • [www.evapco.com](http://www.evapco.com)

### North America

#### EVAPCO, Inc. World Headquarters

Westminster, MD USA  
410.756.2600  
[marketing@evapco.com](mailto:marketing@evapco.com)

#### EVAPCO East

Taneytown, MD USA  
410.756.2600  
[marketing@evapco.com](mailto:marketing@evapco.com)

#### EVAPCO East

Key Building  
Taneytown, MD USA  
410.756.2600  
[marketing@evapco.com](mailto:marketing@evapco.com)

#### EVAPCO Midwest

Greenup, IL USA  
217.923.3431  
[evapcomw@evapcomw.com](mailto:evapcomw@evapcomw.com)

#### EVAPCO West

Madera, CA USA  
559.673.2207  
[contact@evapcwest.com](mailto:contact@evapcwest.com)

#### EVAPCO Iowa

Lake View, IA USA  
712.657.3223

#### EVAPCO Iowa

Sales & Engineering  
Medford, MN USA  
507.446.8005  
[evapcomn@evapcomn.com](mailto:evapcomn@evapcomn.com)

#### EVAPCO Newton

Newton, IL USA  
618.783.3433  
[evapcomw@evapcomw.com](mailto:evapcomw@evapcomw.com)

#### Evapcold Manufacturing

Greenup, IL USA  
217.923.3431  
[evapcomw@evapcomw.com](mailto:evapcomw@evapcomw.com)

#### EVAPCO Dry Cooling, Inc.

Littleton, CO USA  
908.895.3236  
[info@evapcodc.com](mailto:info@evapcodc.com)  
Spare Parts: 908.895.3236  
Spare Parts: [spares@evapcodc.com](mailto:spares@evapcodc.com)

#### EVAPCO Dry Cooling, Inc.

Bridgewater, NJ USA  
908.379.2665  
[info@evapcodc.com](mailto:info@evapcodc.com)

#### EVAPCO Power México S. de R.L. de C.V.

Mexico City, Mexico  
(52) 55.8421.9260  
[info@evapcodc.com](mailto:info@evapcodc.com)

#### Refrigeration Vessels & Systems Corporation

*A wholly owned subsidiary of EVAPCO, Inc.*  
Bryan, TX USA  
979.778.0095  
[rvs@rvscorp.com](mailto:rvs@rvscorp.com)

#### EvapTech, Inc.

*A wholly owned subsidiary of EVAPCO, Inc.*  
Edwardsville, KS USA  
913.322.5165  
[marketing@evaptech.com](mailto:marketing@evaptech.com)

#### Tower Components, Inc.

*A wholly owned subsidiary of EVAPCO, Inc.*  
Ramseur, NC USA  
336.824.2102  
[mail@towercomponentsinc.com](mailto:mail@towercomponentsinc.com)

#### EVAPCO Alcoil, Inc.

*A wholly owned subsidiary of EVAPCO, Inc.*  
York, PA USA  
717.347.7500  
[info@evapco-alcoil.com](mailto:info@evapco-alcoil.com)

### Europe

#### EVAPCO Europe BVBA European Headquarters

Tongeren, Belgium  
(32) 12.39.50.29  
[evapco.europe@evapco.be](mailto:evapco.europe@evapco.be)

#### EVAPCO Europe, S.r.l.

Milan, Italy  
(39) 02.939.9041  
[evapcoeuropa@evapco.it](mailto:evapcoeuropa@evapco.it)

#### EVAPCO Europe, S.r.l.

Sondrio, Italy

#### EVAPCO Europe GmbH

Meerbusch, Germany  
(49) 2159.69560  
[info@evapco.de](mailto:info@evapco.de)

#### EVAPCO Air Solutions

*A wholly owned subsidiary of EVAPCO, Inc.*  
Aabybro, Denmark  
(45) 9824.4999  
[info@evapco.dk](mailto:info@evapco.dk)

#### EVAPCO Air Solutions GmbH

Garbsen, Germany  
(49) 5137.938750  
[info@evapcoas.de](mailto:info@evapcoas.de)

#### Evap Egypt Engineering Industries Co.

*A licensed manufacturer of EVAPCO, Inc.*  
Nasr City, Cairo, Egypt  
(202) 24044997 / (202) 24044998  
[mmanz@tiba-group.com](mailto:mmanz@tiba-group.com) /  
[hany@tiba-group.com](http://hany@tiba-group.com)

#### EVAPCO Middle East DMCC

Dubai, United Arab Emirates  
(971) 4.448.7242  
[info@evapco.ae](mailto:info@evapco.ae)

#### EVAPCO S.A. (Pty.) Ltd.

*A licensed manufacturer of EVAPCO, Inc.*  
Isando, South Africa  
(27) 11.392.6630  
[evapco@evapco.co.za](mailto:evapco@evapco.co.za)

### Asia Pacific

#### EVAPCO Asia Pacific Headquarters

Baoshan Industrial Zone  
Shanghai, P.R. China  
(86) 21.6687.7786  
[marketing@evapcochina.com](mailto:marketing@evapcochina.com)

#### EVAPCO (Shanghai) Refrigeration Equipment Co., Ltd.

Baoshan Industrial Zone, Shanghai, P.R. China  
(86) 21.6687.7786  
[marketing@evapcochina.com](mailto:marketing@evapcochina.com)

#### EVAPCO (Beijing) Refrigeration Equipment Co., Ltd.

Huairou District, Beijing, P.R. China  
(86) 10.6166.7238  
[marketing@evapcochina.com](mailto:marketing@evapcochina.com)

#### EVAPCO Air Cooling Systems (Jiaxing) Company, Ltd.

Jiaxing, Zhejiang, P.R. China  
(86) 573.8311.9379  
[info@evapcochina.com](mailto:info@evapcochina.com)

#### EVAPCO Australia (Pty.) Ltd.

Riverstone, NSW, Australia  
(61) 02.9627.3322  
[sales@evapco.com.au](mailto:sales@evapco.com.au)

#### EvapTech Asia Pacific Sdn. Bhd

*A wholly owned subsidiary of EvapTech, Inc.*  
Puchong, Selangor, Malaysia  
(60) 3.8070.7255  
[marketing-ap@evaptech.com](mailto:marketing-ap@evaptech.com)

### South America

#### EVAPCO Brasil

*Equipamentos Industriais Ltda.*  
Indaiatuba, São Paulo, Brazil  
(55) 11.5681.2000  
[vendas@evapco.com.br](mailto:vendas@evapco.com.br)

#### FanTR Technology Resources

Indaiatuba, São Paulo, Brazil  
(55) 11.4025.1670  
[fantr@fantr.com](mailto:fantr@fantr.com)